

*NRSC
REPORT*

NATIONAL RADIO SYSTEMS COMMITTEE

**NRSC-R54
Evaluation of LDR's Submission to
the NRSC DAB Subcommittee of
Selected Laboratory and Field Test
Results for its FM and AM Band
IBOC System
April 8, 2000**



NAB: 1771 N Street, N.W.
Washington, DC 20036
Tel: (202) 429-5356 Fax: (202) 775-4981



CEA: 1919 South Eads Street
Arlington, VA 22202
Tel: (703) 907-7660 Fax: (703) 907-8113

Co-sponsored by the Consumer Electronics Association and the National Association of Broadcasters
<http://www.nrscstandards.org>

NRSC-R54

NOTICE

NRSC Standards, Guidelines, Reports and other technical publications are designed to serve the public interest through eliminating misunderstandings between manufacturers and purchasers, facilitating interchangeability and improvement of products, and assisting the purchaser in selecting and obtaining with minimum delay the proper product for his particular need. Existence of such Standards, Guidelines, Reports and other technical publications shall not in any respect preclude any member or nonmember of the Consumer Electronics Association (CEA) or the National Association of Broadcasters (NAB) from manufacturing or selling products not conforming to such Standards, Guidelines, Reports and other technical publications, nor shall the existence of such Standards, Guidelines, Reports and other technical publications preclude their voluntary use by those other than CEA or NAB members, whether to be used either domestically or internationally.

Standards, Guidelines, Reports and other technical publications are adopted by the NRSC in accordance with the NRSC patent policy. By such action, CEA and NAB do not assume any liability to any patent owner, nor do they assume any obligation whatever to parties adopting the Standard, Guideline, Report or other technical publication.

This Guideline does not purport to address all safety problems associated with its use or all applicable regulatory requirements. It is the responsibility of the user of this Guideline to establish appropriate safety and health practices and to determine the applicability of regulatory limitations before its use.

Published by
CONSUMER ELECTRONICS ASSOCIATION
Technology & Standards Department
1919 S. Eads St.
Arlington, VA 22202

NATIONAL ASSOCIATION OF BROADCASTERS
Science and Technology Department
1771 N Street, NW
Washington, DC 20036

©2008 CEA & NAB. All rights reserved.

This document is available free of charge via the NRSC website at www.nrscstandards.org. Republication or further distribution of this document, in whole or in part, requires prior permission of CEA or NAB.

FOREWORD

NRSC-R54, Evaluation of LDR's Submission to the NRSC DAB Subcommittee of Selected Laboratory and Field Test Results for its FM and AM Band IBOC System, documents the results of the NRSC's evaluation of the Lucent Digital Radio (LDR) IBOC system, based upon test data submitted by LDR to the NRSC on January 24, 2000. This evaluation was conducted by the Evaluation Working Group of the DAB Subcommittee. The DAB Subcommittee chairman at the time of adoption of NRSC-R54 was Milford Smith; the NRSC chairman at the time of adoption was Charles Morgan.

The NRSC is jointly sponsored by the Consumer Electronics Association and the National Association of Broadcasters. It serves as an industry-wide standards-setting body for technical aspects of terrestrial over-the-air radio broadcasting systems in the United States.



2500 Wilson Boulevard
Arlington, VA 22201-3834
(703) 907-7500
FAX (703) 907-7501

**NATIONAL
RADIO
SYSTEMS
COMMITTEE**



1771 N Street, NW
Washington, DC 20036-2891
(202) 429-5346
FAX (202) 775-4981

DAB Subcommittee

**EVALUATION OF
LUCENT DIGITAL RADIO'S
SUBMISSION TO THE NRSC DAB SUBCOMMITTEE
OF SELECTED LABORATORY AND FIELD TEST
RESULTS
FOR ITS FM AND AM BAND IBOC SYSTEM**

**Report from the
Evaluation Working Group
Dr. H. Donald Messer, Chairman**

(as adopted by the Subcommittee on April 8, 2000)

Table of Contents

1	INTRODUCTION.....	4
1.1	NRSC DAB SUBCOMMITTEE GOALS AND OBJECTIVES.....	5
1.2	EVALUATION PROCESS DECISIONS MADE.....	5
1.2.1	<i>Test guidelines would be established.....</i>	5
1.2.2	<i>Formation and functioning of the Evaluation Working Group.....</i>	5
1.2.3	<i>Agreements on IBOC system scope and NRSC reporting of its evaluations.....</i>	6
1.3	MUCH WORK DONE; MUCH WORK LEFT TO DO.....	7
2	CONCLUSION.....	8
3	DISCUSSION OF FINDINGS	9
3.1	CRITERIA USED FOR EVALUATION	9
3.2	FM IBOC SYSTEM EVALUATION – FINDINGS.....	9
3.2.1	<i>Criterion 1 – Audio quality.....</i>	10
3.2.2	<i>Criteria 2, 3 – Service area, durability.....</i>	10
3.2.3	<i>Criterion 4 – Acquisition performance.....</i>	11
3.2.4	<i>Criterion 5 – Auxiliary data capacity.....</i>	11
3.2.5	<i>Criterion 6 – Behavior as signal degrades.....</i>	11
3.2.6	<i>Criterion 7 – Stereo separation.....</i>	12
3.2.7	<i>Criterion 8 – Flexibility.....</i>	12
3.2.8	<i>Criterion 9 – Host analog signal impact.....</i>	12
3.2.9	<i>Criterion 10 - Non-host analog signal impact.....</i>	13
3.3	AM IBOC SYSTEM EVALUATION – MAJOR FINDINGS.....	13
3.3.1	<i>Criterion 1 – Audio quality.....</i>	14
3.3.2	<i>Criteria 2, 3 – Service area, durability.....</i>	14
3.3.3	<i>Criterion 4 – Acquisition performance.....</i>	15
3.3.4	<i>Criterion 5 – Auxiliary data capacity.....</i>	15
3.3.5	<i>Criterion 6 – Behavior as signal degrades.....</i>	16
3.3.6	<i>Criterion 7 – Stereo separation.....</i>	16
3.3.7	<i>Criterion 8 – Flexibility.....</i>	16
3.3.8	<i>Criterion 9 – Host analog signal impact.....</i>	16
3.3.9	<i>Criterion 10 - Non-host analog signal impact.....</i>	17
	APPENDIX A – DAB SUBCOMMITTEE GOALS & OBJECTIVES	18
	APPENDIX B – IBOC DAB SYSTEM TEST GUIDELINES – PART I – LABORATORY TESTS.....	19
	APPENDIX C – IBOC DAB SYSTEM TEST GUIDELINES – PART II – FIELD TESTS	20
	APPENDIX D – IBOC DAB SYSTEM EVALUATION GUIDELINES	21
	APPENDIX E – NRSC IBOC SYSTEM EVALUATION MATRIX	22
	APPENDIX F – LDR SUBMISSION – TESTS SUBMITTED.....	23
	APPENDIX G – LDR COMMENTS ON THIS EVALUATION REPORT.....	24

List of tables

TABLE 1. EWG EVALUATION CRITERIA9
TABLE 2. FM IBOC TEST RESULTS SUBMITTED BY LDR PERTAINING TO AUDIO QUALITY10
TABLE 3. FM IBOC TEST RESULTS SUBMITTED BY LDR PERTAINING TO SERVICE AREA AND DURABILITY11
TABLE 4. FM IBOC TEST RESULTS SUBMITTED BY LDR PERTAINING TO HOST ANALOG SIGNAL IMPACT13
TABLE 5. AM IBOC TEST RESULTS SUBMITTED BY LDR PERTAINING TO SERVICE AREA AND DURABILITY14

List of figures

FIGURE 1. COMPARISON OF DUAL 1ST ADJ. INTERFERER TEST RESULTS.....15

1 INTRODUCTION

This report is submitted to the National Radio Systems Committee's Digital Audio Broadcasting Subcommittee from its Evaluation Working Group (EWG) in accordance with procedures that were established by the Subcommittee during meetings in 1999.

In summary:

- The EWG developed evaluation criteria and a System Evaluation Guidelines document that delineated the manner in which evaluations would be conducted;
- The basis for conducting tests and reporting results by a proponent were contained in two other NRSC DAB Subcommittee documents: one on laboratory tests, the other on field tests;
- The EWG, in designing the basis for its evaluations, developed a two dimensional table that arrayed the individual tests in the laboratory and field test guidelines documents with the ten basic evaluation criteria agreed upon;
- IBOC system proponents agreed to tender submissions on December 15, 1999;
- For each submission, an evaluation report (such as this one) would be developed;
- The NRSC's evaluation would be a comparison of the IBOC system(s) performance with the current performance of analog radio in the FM and AM broadcasting bands.

The Chairman expresses his hearty thanks to the 20 or so members of the EWG. An enormous amount of work was done, on a voluntary basis for most of the members, since early March 1999. The EWG membership included representatives of the broadcasting industry, the receiver manufacturing industry, the proponent organizations, and staff and consultants from NAB and CEA. With respect to the last category, special thanks goes to David Layer of NAB for carrying the brunt of the development of the documentation, taking care of the minutes of the telcon and full meetings of the working group, and contributing significantly to the analysis.

This report is organized as follows:

- Introduction: this section briefly reviews the process and events leading up to the generation of this evaluation report;
- Conclusion: a statement of the EWG's conclusions regarding the LDR IBOC submission including suggestions for future work;
- Discussion of findings: a detailed presentation of the data submitted, analysis performed, and conclusions reached, organized according to evaluation criteria established by the EWG;
- Appendices: supplemental information including analyses performed by the EWG during the course of its evaluation.

1.1 NRSC DAB SUBCOMMITTEE GOALS AND OBJECTIVES

The NRSC's DAB Subcommittee established goals and objectives on May 14, 1998 for the work to be done by it as a result of the re-activation of the Subcommittee (see Appendix A for the complete Goals and Objectives statement).

What the primary objective is:

The purpose of the current NRSC effort is to determine if current generation IBOC technology is a significant improvement over the analog systems currently in use. In other words, the evaluative quest is to determine if the current state-of-the-art of IBOC technology merits the conclusion that continuing to pursue IBOC technology, through all its technical and regulatory ramifications, is in the interest of U.S. listeners.

What is not an objective of the current work:

The work that has been done by the Subcommittee since mid-1998 has not dealt in any way with comparing the performances among different IBOC systems. This is due primarily to the fact that there have been no comparative tests (neither planned nor conducted) between different systems as would be necessary for valid comparisons to be made.

1.2 EVALUATION PROCESS DECISIONS MADE

From mid-1998 up to and including a meeting of the NRSC DAB Subcommittee that took place on April 17, 1999, several important decisions were made that established the construct of the overall evaluation process. These are summarized in this section.

1.2.1 Test guidelines would be established

The NRSC developed detailed laboratory and field test guidelines, which would explain to proponents the tests and information the NRSC deemed necessary for evaluating IBOC systems. These were developed by the DAB Subcommittee's Test Guidelines Working Group, Mr. Andy Laird, Chairman, during the second half of 1998 and early in 1999. They were approved by the Subcommittee in early 1999 (and are included with this report as Appendices B and C).

In construct, the recommended test protocols in the Guidelines documents were similar to those from an earlier EIA/NRSC DAB test process (conducted during the 1994-95 time frame), refined from then and dealing solely with testing of IBOC systems. The various test protocols include ways of eliciting IBOC system performance and the effects of the IBOC digital carriers on its host and adjacent channel analog (and digital) signals, and vice versa.

1.2.2 Formation and functioning of the Evaluation Working Group

In early 1999 the EWG was established, having its first meeting in early March 1999. An initial report was submitted to the Subcommittee at its April 1999 meeting in the form of the first version of a System Evaluation Guidelines document (complementary to the test guidelines documents mentioned

above). Subject to the incorporation of a few points of modification, the document was approved at the April 17th meeting (see [Appendix D](#)).

The EWG then developed ten (10) system evaluation criteria. These covered, at a high level directly related to broadcasting, those areas upon which the comparison with analog radio broadcasting would be based.

The working group also developed a cross-reference table between all the individual test protocols of the laboratory test and field test guidelines documents and each of the 10 evaluation criteria. This work was completed subsequent to the April 17th Subcommittee meeting, and the resulting table is being used in the evaluation of this current submission by LDR (see [Appendix E](#)).

1.2.3 Agreements on IBOC system scope and NRSC reporting of its evaluations

Five important provisions were agreed to at the April 17th Subcommittee meeting that bear on the submission of information to the NRSC DAB Subcommittee and on the reporting of the evaluation:

1. ***Complete hybrid (IBOC) system:*** any submission must document a full system, that is, one that is capable of IBOC operation in both the AM and FM broadcasting bands.
2. ***Data on an “all digital” system not evaluated at this time:*** although the ultimate objective for terrestrial radio broadcasting is likely to be full conversion to digital transmission, it is recognized that this will take many years as the conversion of thousands of stations takes place. Therefore, even though some proponents are working on “all digital” designs as part of their efforts, a decision was made to limit the current evaluation to the more pressing (and presumed more difficult) “hybrid IBOC” aspect of the conversion.
3. ***Only the performance of the IBOC system will be evaluated:*** several aspects of IBOC implementation are not to be evaluated, for example, the extent of transmitter conversion required and the expected cost of receivers. In summary, the technical and performance aspects of the system are to be evaluated. This includes the performance of the digital carriers as well as the impact the digital carriers have on its own host analog signal as well as on adjacent channel signals.
4. ***The NRSC will generate a separate report for each system submitted:*** in line with the decision to evaluate with respect to analog performance, and not to compare performance among digital systems, a separate evaluation report will be produced for each system for which system descriptions and data are submitted. This report, thus, deals exclusively with the LDR system in comparison with today’s AM and FM modulation in their respective broadcasting bands.
5. ***Submission date - December 15, 1999:*** December 15, 1999 was agreed to by the proponents as the submission date for system descriptions and test data at the April 17, 1999 Subcommittee meeting.

On December 8, 1999, LDR informed the NRSC that it would be unable to make a submission on December 15, 1999, and instead would like to make a submission on January 24, 2000, coinciding with the comment deadline in the FCC’s NPRM on terrestrial DAB. The DAB Subcommittee agreed to accept a submission from them on that date, and in addition, another proponent (USADR) was also given an additional two week submission “window,” following the 1/24/00 LDR submission date. (USADR tendered its submission on December 15, 1999.)

1.3 MUCH WORK DONE; MUCH WORK LEFT TO DO

The DAB Subcommittee and its Test Guidelines Working Group have expended considerable effort in identifying the tests (specified in the Field Test and Lab Test Guidelines) that a proponent needs to perform, in order for the NRSC to be able to determine if a system is significantly improved over analog services. While some tests may be more vital in achieving this end than others, they all play a part in the process – each specified test is important and offers a unique insight into system performance.

A comparison of the test results which LDR has included in its submission with what is requested in the guidelines reveals that a substantial amount of information important to this evaluation has not been provided. LDR, at the time of its submission, indicated that due to time constraints involved with meeting internal system development objectives, its submission would include data taken only from its existing test program. Even though the specific tests detailed in the NRSC test guidelines were not performed, the LDR submission is valuable in helping the DAB Subcommittee work towards its present goal of comparing IBOC performance to analog system performance. It represents a considerable effort on the part of the proponent as well as providing the most complete technical “glimpse” of its system yet offered to the industry.

A comparison of the tests included in LDR’s submission with the tests specified in the NRSC’s Lab and Field Test Guidelines indicates the following number of tests were conducted. For FM lab tests, of the 67 specified in the guidelines, at least partial results were submitted for 5. For FM field tests, of the 12 tests specified in the guidelines, partial results for 4 were submitted. For AM lab tests, of the 25 specified tests, partial results on 5 were submitted. Finally, for the AM field tests, of the 8 specified tests, partial results for 0 were submitted.

The evaluation described in this report focuses on the information which was provided, and in some instances notes the absence of important data or factors not included in a test which, if present, would have offered additional valuable (if not vital) information. Clearly, additional information will be needed before the EWG, and ultimately the DAB Subcommittee, can be in a position to establish with technical rigor whether IBOC is a significant improvement over today’s analog services. This report represents the very best efforts of the EWG to evaluate the data submitted by LDR in light of the fact that specific NRSC test guidelines were not followed.

2 CONCLUSION

The basic conclusion: the “state-of-the-art” for IBOC technology indicates the reasonable probability of substantial improvement for broadcast listening compared to current analog performance in the AM and FM broadcasting bands.

LDR’s submission should be considered as a “sample point” to aid in determining whether IBOC “state-of-the-art” is good enough to have interested parties in the U.S. believe that this avenue for the implementation of digital radio is the path to pursue. The EWG notes that improvements in IBOC system performance are likely as the system development process continues.

Also, as noted elsewhere in this report, a significant number of the recommended tests from the Subcommittee’s laboratory and field test guidelines were neither conducted, nor reported, nor was there an adequate substituted test procedure that would permit us to evaluate results according to one or more of the ten agreed upon evaluation criteria.

LDR’s reported test results were primarily subjective audio listening assessments. While useful, the lack of objective laboratory test results and objective field test results prevented us from conducting a careful evaluation of system performance. The subjective listening test results supplied indicated better performance of the IBOC system than that of the analog performance being compared. Even here, however, there was some concern about the subjective test procedure used.

Therefore, the basic conclusion stated above is one that should be considered to be heavily qualified. This is because the EWG was unable to assess performance under some of the evaluation criteria with adequate engineering credibility. This is true more for the AM IBOC system than for the FM IBOC system, since very little AM IBOC information was provided.

Based upon this evaluation, the EWG is optimistic that LDR is on the proper track to develop IBOC DAB systems with the potential to significantly improve AM and FM radio broadcasting in the U.S. Encouragement is hereby given to LDR that it continue to develop its systems and test them in accordance with independent test procedures crafted in cooperation with the broadcast and consumer electronics industries.

3 DISCUSSION OF FINDINGS

In this section, the details of LDR’s submission to the NRSC are presented, organized with respect to how each part of the submission relates to the EWG’s 10 evaluation criteria. After presenting the data, a review of the EWG analysis followed by the conclusions which were arrived at are then given.

Note that since the tests and results described in the LDR submission were organized differently from the DAB Subcommittee’s test guidelines documents, the first step in this process was for the EWG to determine how the submitted information corresponded to the tests specified in the guidelines (Appendix F). In the sections which follow, slightly modified versions of the tables in Appendix F are presented for each criteria, indicating for each submitted result the location of data/graph information (in the submission), any corresponding audio recordings submitted, and how that result would be compared against the existing analog service (indicated in the “analog benchmark” column).

3.1 Criteria used for evaluation

The EWG established 10 criteria to use for evaluating IBOC submissions. These criteria fall into two general categories: “IBOC receiver” results, which apply to data obtained directly from the IBOC receiver (e.g., unimpaired audio quality of an IBOC signal, service area and durability of the IBOC signal, etc.); and, “Analog receiver” results, which address the compatibility of the IBOC signal with existing analog receivers.

Table 1 lists the evaluation criteria according to category. Refer to Appendix E for a detailed description of each criterion, as well as for a matrix which illustrates which tests (contained in the test guidelines) have a bearing upon which criteria.

Table 1. EWG evaluation criteria

IBOC RECEIVER RESULTS	ANALOG RECEIVER RESULTS
Audio quality	Host analog signal impact
Service area	Non-host analog signal impact
Durability	
Acquisition performance	
Auxiliary data capacity	
Behavior as signal degrades	
Stereo separation	
Flexibility	

3.2 FM IBOC system evaluation – findings

Since receiving the LDR submission on January 24, 2000, the EWG has undertaken an extensive review and analysis of the FM IBOC system test results and information presented. The results of this review are presented here in detail, organized according to evaluation criteria.

3.2.1 Criterion 1 – Audio quality

Table 2 lists the test results submitted by LDR pertaining to audio quality of their FM IBOC system. In this context, audio quality refers to the *unimpaired* audio quality of the system i.e. the audio quality absent any channel impairments or interferers.

Table 2. FM IBOC test results submitted by LDR pertaining to audio quality

TEST NO. (GUIDELINES)	DATA/GRAPHS	AUDIO RECORDINGS	BENCHMARK	COMMENTS
K2 (lab) – DAB quality – subjective assessment report of unimpaired IBOC audio quality vs. analog FM	<ul style="list-style-type: none"> • Fig. 1 (Appendix F.3, pg. 5) – Participants’ ACR responses (averaged) • Fig. 2 (Appendix F.3, pg. 6) – Participants’ ACR responses (by audio material) 	Cut 5 (Multi-streaming PAC at 128 kbps) Cut 7 (Multi-streaming PAC at 64 kbps)	<ul style="list-style-type: none"> • Included with submission – (and used for subjective evaluation) refer to audio cuts 1 (CD source), 3 (FM reference) 	<ul style="list-style-type: none"> • Audio material - Critical audio cuts listed in Table 1 of Appendix F.3. • Subjective evaluation performed on DAB recordings as well as FM reference and CD source • PAC recordings may or may not have been passed through an IBOC system.

While LDR has provided a subjective evaluation of unimpaired audio quality as requested in the test guidelines, there are a number of differences between what was submitted and what the NRSC requested in this regard. Ultimately, these differences make it difficult to interpret the results presented, and the EWG is unable to endorse the conclusions presented by LDR in their submission.

Conclusion: based solely on the subjective evaluation offered, the LDR FM IBOC audio appears to be an improvement over analog FM, but the nature of this improvement is not understood and needs to be investigated more fully.

3.2.2 Criteria 2, 3 – Service area, durability

Table 3 lists the test results submitted by LDR pertaining to service area and durability of their FM IBOC system. These two criteria have been combined in this section because they share the same list of tests (from the test guidelines) from which conclusions can be drawn.

The EWG intended to evaluate these criteria separately for IBOC audio and IBOC auxiliary data capacity. LDR submitted no information about the auxiliary data aspects of their system, so this evaluation is limited to consideration of IBOC audio performance.

Table 3. FM IBOC test results submitted by LDR pertaining to service area and durability

TEST NO. (GUIDELINES)	DATA/GRAPHS	AUDIORECORDINGS	BENCHMARK	COMMENTS
B3 (lab) – AWGN, multipath fading channel, no interferers	<ul style="list-style-type: none"> • Fig. F1-1 (pg. 3) – Signal quality as a function of the receiver distance from the transmitter 		<ul style="list-style-type: none"> • Included with submission – (and used for subjective evaluation) FM in static channel, FM with fast fading also included in Fig. F1-1 along with IBOC data. 	<ul style="list-style-type: none"> • Audio material - Critical audio cuts listed in Table 1 of Appendix F.3. • Noise not added; signal strength reduced instead
B4 (lab) – AWGN, multipath fading channel, 1st adj. channel interferer	<ul style="list-style-type: none"> • Fig. F1-2 (pg. 7) – Signal quality as a function of the receiver distance from the transmitter w/1st. adj. interferer • Appendix F.4, Table 7 – Performance of LDR IBOC system subjected to 1st adj. chnl. and fast rural fading 		<ul style="list-style-type: none"> • Included with submission – (and used for subjective evaluation) FM with 1st adj. channel interference also included in Fig. F1-2 along with IBOC data. 	<ul style="list-style-type: none"> • Mobile receivers only used in fading tests
B1,2 (field) – Strong signal with low interference – low and strong multipath	(none)	Cut 9 (Field test demonstration audio)	<ul style="list-style-type: none"> • None – no impairment observations made, no corresponding analog audio 	<ul style="list-style-type: none"> • Demonstration of multistreaming PAC at 128 kbps • This data would seem to be unusable.
C 1,3 (field) – Single interferer at, above FCC limit				

The results presented by LDR are subjective evaluations. While valuable and somewhat encouraging, these results are not sufficient for the EWG to arrive at definitive conclusions regarding service area and durability.

Conclusions – service area and durability: presented data is encouraging but more information is needed.

3.2.3 Criterion 4 – Acquisition performance

LDR did not submit test results pertaining specifically to the acquisition performance of its FM IBOC system. Furthermore, the provided system description information did not address the issue of acquisition performance.

Conclusion: EWG analysis is inconclusive due to lack of information.

3.2.4 Criterion 5 – Auxiliary data capacity

LDR did not submit test results pertaining specifically to the auxiliary data capacity of its FM IBOC system. Furthermore, the provided system description information did not address the issue of auxiliary data capacity.

Conclusion: EWG analysis is inconclusive due to lack of information.

3.2.5 Criterion 6 – Behavior as signal degrades

LDR did not submit test results pertaining specifically to the FM IBOC system behavior as signal degrades. In the system description portion of their submission, LDR indicates that their multi-streaming technology provides for "...graceful degradation of the digital audio signal."¹

Conclusion: EWG analysis is inconclusive due to lack of information.

3.2.6 Criterion 7 – Stereo separation

While it would have been theoretically possible to perform a preliminary analysis on this aspect of system performance based on some of the audio files submitted, the EWG elected not to perform this analysis.

Conclusion: EWG analysis is inconclusive due to lack of information.

3.2.7 Criterion 8 – Flexibility

In their submission, LDR describes an "all-digital" IBOC technology to complement its hybrid design, and offers additional performance and service benefits.² Its system is also expected to provide support for auxiliary data services, however its submission does not elaborate on this.

Conclusion: the amount of flexibility which this system will support cannot be established at this time, due primarily to the fact that the system is still being tested and refined. By its very nature, IBOC technology involves tradeoffs between coverage, robustness, and flexibility. Only when the final system parameters which best balance these parameters are chosen will it be possible to competently judge the flexibility of the system.

3.2.8 Criterion 9 – Host analog signal impact

Table 4 lists the test results submitted by LDR pertaining to host analog signal impact of its FM IBOC system.

¹ See LDR submission, part III, pg. 3.

² See LDR submission, Appendix D, pg. 3.

Table 4. FM IBOC test results submitted by LDR pertaining to host analog signal impact

TEST NO. (GUIDELINES)	DATA/GRAPHS	AUDIORECORDINGS	BENCHMARK	COMMENTS
L1 (lab) – IBOC “digital-to-host analog” compatibility performance – host analog main channel audio, linear channel	<ul style="list-style-type: none"> Appendix G, Fig. 1a, 1b (pg. 10) – Combined and expert listener overall responses Appendix G, Fig 2a, 2b (pgs. 11, 12) – Audio quality ratings by receiver and multipath conditions Appendix F.4, Table 3 (1st table 3, pg. 7) – ACR MOS by sound sample Appendix F.4, Fig. 1 (pg. 6) – ACR MOS vs. avg. RF signal level (static cond.) (see Appendix G Data/Graphs for test L1 above)	(none)	<ul style="list-style-type: none"> Included with submission – (and used for subjective evaluation) host signal with digital sidebands removed None – no corresponding audio without IBOC sidebands recorded 	<ul style="list-style-type: none"> 5 analog receivers used IBOC carriers turned on and off for these tests 4 analog receivers used Subj. eval. vs. signal strength – IBOC carriers always on
L2 (lab) – IBOC “digital-to-host analog” compatibility perf. – host analog main chan. audio, fading chan.		(none)	<ul style="list-style-type: none"> Included with submission – (and used for subjective evaluation) host signal with digital sidebands removed 	<ul style="list-style-type: none"> 5 analog receivers used IBOC carriers turned on and off for these tests
* Host analog main channel audio performance with fading	<ul style="list-style-type: none"> Appendix F.4, Table 3 (2nd table 3, pg. 9) – ACR MOS by sound sample 	(none)	<ul style="list-style-type: none"> None – no corresponding audio without IBOC sidebands recorded 	<ul style="list-style-type: none"> 2 mobile receivers used (in fading tests only); 4 non-mobile receivers used
* Host analog main channel audio performance with 1st adj. interference	<ul style="list-style-type: none"> Appendix F.4, Tables 4, 5 (pgs. 10, 11) – ACR MOS w/1st adj. chan. interference 	(none)		<ul style="list-style-type: none"> Subj. eval. vs. signal strength – IBOC carriers always on
* Host analog main channel audio performance vs. output SNR	<ul style="list-style-type: none"> Appendix F.4, Table 6 (pg. 12) – ACR MOS vs. SNR 			

The results presented by LDR are subjective evaluations. While valuable and somewhat encouraging, these results are not sufficient for the EWG to arrive at definitive conclusions regarding host analog signal impact.

Specifically, no audio recordings were submitted which would have allowed the EWG to determine whether or not the presence of the digital carriers was noticeable on the host audio signal for the receivers tested. Nor were any objective measurements of host audio S/N ratio presented demonstrating quantitatively any effect which the presence of the digital carriers may be having.

Conclusion: EWG analysis is inconclusive on this criterion due to lack of information. Additional measurements are needed to rigorously establish the effect that the digital carriers have on the analog host.

3.2.9 Criterion 10 - Non-host analog signal impact

LDR did not submit any test results pertaining to the how the FM IBOC system impacts on a non-host analog signal.

Conclusion: EWG analysis is inconclusive on this due to lack of information.

3.3 AM IBOC system evaluation – major findings

Since receiving the LDR submission on January 24, 2000, the EWG has undertaken an extensive review and analysis of the AM IBOC system test results and information presented. The results of this review are presented here in detail, organized according to evaluation criteria.

3.3.1 Criterion 1 – Audio quality

LDR did not submit any test results pertaining to the unimpaired audio quality of its AM IBOC system.

Conclusion: EWG analysis is inconclusive on this due to lack of information.

3.3.2 Criteria 2, 3 – Service area, durability

Table 5 lists the test results submitted by LDR pertaining to service area and durability of its AM IBOC system.

Table 5. AM IBOC test results submitted by LDR pertaining to service area and durability

TEST NO. (GUIDELINES)	DATA/GRAPHS	AUDIO RECORDINGS	BENCHMARK	COMMENTS
B1 (lab) – AWGN, linear channel, no interferers	• Tbl. L-1 (pg. 6) – AM hybrid performance with AWGN (FER vs. RF S/N ratio)	(none)	<ul style="list-style-type: none"> Analytical comparison to analog – estimate IBOC “digital TOA service area” by calculating analog field strength at digital TOA operating point, and compare this to analog protected contour 	<ul style="list-style-type: none"> Analog bandlimited to ± 4.5 kHz (all cases) FER given for all 3 streams For co-channel tests, both carriers are IBOC Data from test H3 serves nicely as a benchmark for test D3 (lab) results below
C2 (lab) – IBOC system performance with special impairments – weak sig.	• Tbl. J-2 (pg. 7) – Receiver sensitivity (FER vs. RF signal level)			
D1 (lab) – IBOC “digital-to-digital” compatibility performance – linear chan., w/co-chan. intf.	• Tbl. J-3 (pg. 8) – AM IBOC co-channel interference (FER vs. co-channel D/U)			
H3 (lab) – IBOC “analog-to-digital” compatibility performance – simultaneous upper and lower 1st adj. interferers	• Tbl. J-4 (pg. 10) – Performance with upper and lower analog 1st adj. interference (FER vs. 1st adj. D/U)	(none)	<ul style="list-style-type: none"> Measured results – refer to test H-3 results (included in submission) which are from same test as D-3 except using analog interferers (see supplemental graph in report) 	<ul style="list-style-type: none"> Both interferers are IBOC FER given for all 3 streams Analog band limited to ± 4.5 kHz
D3 (lab) – IBOC “digital-to-digital” compatibility performance – linear chnl., w/simultaneous upper and lower 1st adj. interferers	• Tbl. J-5 (pg. 11) – Performance with upper and lower 1st adj. AM IBOC interference (FER vs. 1st adj. D/U)			
* D/H (lab) – IBOC compatibility performance	• Tbl. J-6 (pg. 13) – Performance in presence of upper 1st and upper 2nd adj. AM IBOC interference (FER vs. 1st and 2nd adj. D/U)	(none)	<ul style="list-style-type: none"> Analytical comparison to analog – estimate IBOC “digital TOA service area” by calculating analog field strength at digital TOA operating point, and compare this to analog protected contour 	<ul style="list-style-type: none"> Various combinations of 1st, 2nd adj. chnl. D/U tested FER given for all 3 streams

* indicates test not specified by NRSC’s test guidelines.

The submitted results, consisting of FER measurements versus various operating parameters, demonstrate the robustness of the different “streams” which make up the LDR digital waveform. Two of the tests, “D3” and “H3” (using the NRSC guidelines designations) lent themselves to direct comparison, the results of which are presented in Figure 1. This plot suggests that in the case of dual 1st adjacent interferers, the IBOC digital carrier energy (in the adjacent channels) is degrading the AM IBOC performance by a substantial amount (>10 dB) compared to the case where the interferers are solely analog carriers.³

³ Note that in the case of the analog interferers, these interferers have significantly reduced bandwidth (±4.5 kHz) than would typical AM interferers (which would have a bandwidth of ±10 kHz). Consequently, the actual performance difference between typical AM interferers and LDR AM IBOC interferers is unknown.

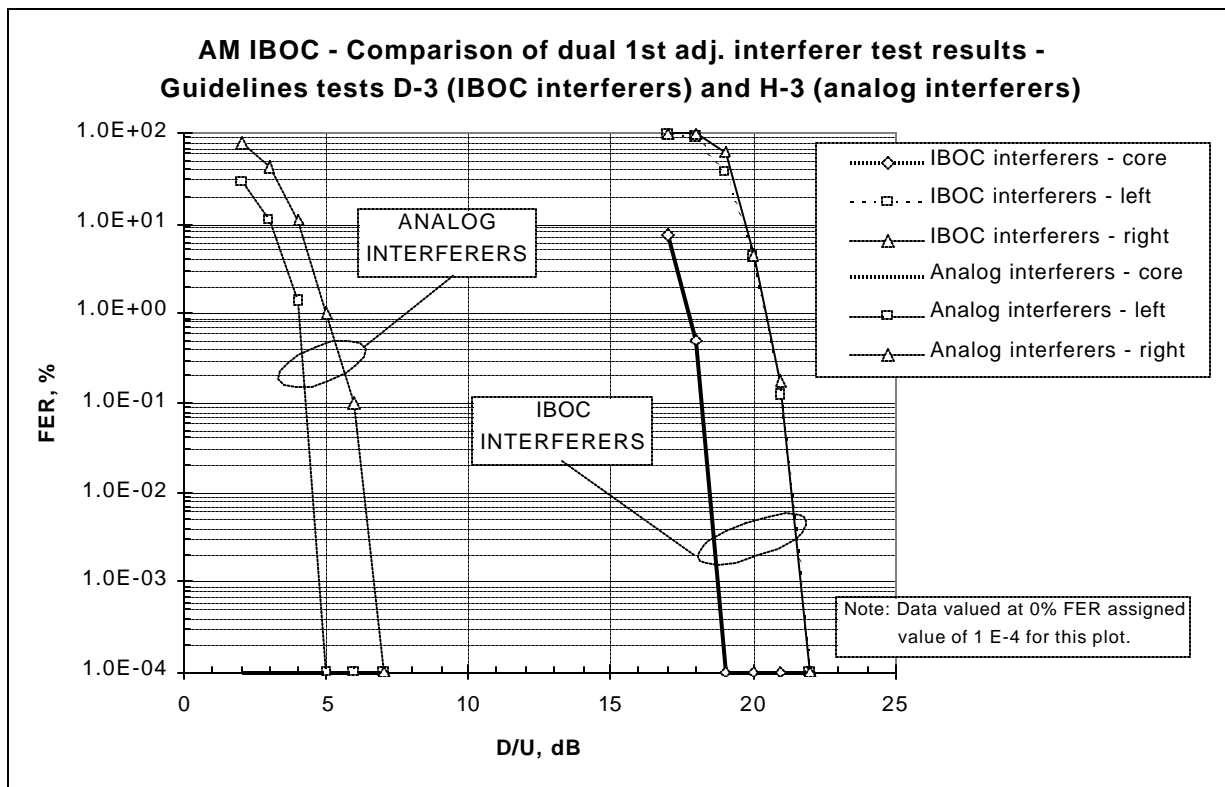

Figure 1. Comparison of dual 1st adj. interferer test results

This information, while interesting, when taken in isolation does little to help the EWG determine anything definitive regarding a comparison of service area and durability between LDR’s AM IBOC and analog AM service.

Conclusion – service area and durability: more information is needed before conclusions can be drawn on these criteria.

3.3.3 Criterion 4 – Acquisition performance

LDR did not submit any test results pertaining specifically to the acquisition performance of its AM IBOC system.

Conclusion: EWG analysis is inconclusive on this due to lack of information.

3.3.4 Criterion 5 – Auxiliary data capacity

LDR did not submit any test results pertaining specifically to the auxiliary data capacity of its AM IBOC system.

Conclusion: EWG analysis is inconclusive on this due to lack of information.

3.3.5 Criterion 6 – Behavior as signal degrades

LDR did not submit any test results pertaining specifically to the FM IBOC system behavior as signal degrades. In the system description portion of their submission, LDR indicates that its AM system utilizes multi-streaming technology, which is described as providing for “...graceful degradation of the digital audio signal.”⁴

Conclusion: EWG analysis is inconclusive on this due to lack of information.

3.3.6 Criterion 7 – Stereo separation

While it would have been theoretically possible to perform a preliminary analysis on this aspect of system performance based on some of the audio files submitted, the EWG elected not to perform this analysis.

Conclusion: EWG analysis is inconclusive on this due to lack of information.

3.3.7 Criterion 8 – Flexibility

In their submission, LDR describes an “all-digital” IBOC technology which complements their hybrid design and offers additional performance and service benefits.⁵ Its system is also expected to provide support for auxiliary data services, however their submission does not elaborate on this.

Conclusion: The amount of flexibility which this system ultimately supports cannot be established at this time, due not only to the fact that the features allowing for flexible operation have not been reported on in the present submission, but also to the fact that the system is still being tested and refined. By its very nature, IBOC technology involves a number of tradeoffs between such aspects of performance as coverage, robustness, and flexibility. Only when the final system parameters which best balance these parameters are chosen will it be possible to competently judge the flexibility of the system.

3.3.8 Criterion 9 – Host analog signal impact

Normally when considering this criterion, the goal is to determine how the presence of the digital carriers affect the reception of the co-located analog “host” signal on existing analog receivers. Ideally, the impact will be slight; the EWG recognizes that it would be unrealistic to expect no impact due to the nature of IBOC system design. Indeed, one of the many challenges that IBOC designers face is how to trade off digital carrier coverage against impact caused to the host analog signal.

In their submission, LDR did not include any test results or information which would provide insight into host analog signal impact in the normal sense. One part of the system information portion of the submission does bear upon this criterion, specifically, the fact that the LDR AM IBOC system

⁴ See LDR submission, part III, pg. 3. While this comment was directed at their FM system, the EWG understands that it applies to their AM system, as well.

⁵ See LDR submission, Appendix I, pg. 9.

requires a reduction in bandwidth of the analog signal, from ± 10 kHz to ± 4.5 kHz. The EWG has some concerns about this requirement. However, some broadcasters may find this reduced bandwidth an acceptable tradeoff in a transition to digital services.

Conclusion: the EWG cannot conclude anything about the host analog signal impact performance of the LDR AM IBOC system due to a lack of information. However, there is some concern on the part of the EWG with respect to the reduction in analog signal bandwidth required by the AM IBOC system design.

3.3.9 Criterion 10 - Non-host analog signal impact

LDR did not submit any test results pertaining to the non-host analog signal impact of its AM IBOC system. As with host analog signal impact, ideally, the impact on non-host analog signals due to the IBOC digital carriers will be slight; the EWG recognizes that it would be unrealistic to expect no impact due to the nature of IBOC system design.

Conclusion: EWG analysis is inconclusive on this due to lack of information.

**Appendix A –
DAB Subcommittee Goals & Objectives**



2500 Wilson Boulevard
Arlington, VA 22201-3834
(703) 907-7500
FAX (703) 907-7501

NATIONAL RADIO SYSTEMS COMMITTEE



1771 N Street, NW
Washington, DC 20036-2891
(202) 429-5339
FAX (202) 775-4981

5/14/98

DAB Subcommittee Goals & Objectives

(as adopted by the Subcommittee on May 14, 1998)

Objectives

- (a) To study IBOC DAB systems and determine if they provide broadcasters and users with:
- A digital signal with significantly greater quality and durability than available from the AM and FM analog systems that presently exist in the United States;
 - A digital service area that is at least equivalent to the host station's analog service area while simultaneously providing suitable protection in co-channel and adjacent channel situations;
 - A smooth transition from analog to digital services.
- (b) To provide broadcasters and receiver manufacturers with the information they need to make an informed decision on the future of digital audio broadcasting in the United States, and if appropriate to foster its implementation.

Goals

To meet its objectives, the Subcommittee will work towards achieving the following goals:

- (a) To develop a technical record and, where applicable, draw conclusions that will be useful to the NRSC in the evaluation of IBOC systems;
- (b) To provide a direct comparison between IBOC DAB and existing analog broadcasting systems, and between an IBOC signal and its host analog signal, over a wide variation of terrain and under adverse propagation conditions that could be expected to be found throughout the United States;
- (c) To fully assess the impact of the IBOC DAB signal upon the existing analog broadcast signals with which they must co-exist;
- (d) To develop a testing process and measurement criteria that will produce conclusive, believable and acceptable results, and be of a streamlined nature so as not to impede rapid development of this new technology;
- (e) To work closely with IBOC system proponents in the development of their laboratory and field test plans, which will be used to provide the basis for the comparisons mentioned in Goals (a) and (b);
- (f) To indirectly participate in the test process, by assisting in selection of (one or more) independent testing agencies, or by closely observing proponent-conducted tests, to insure that the testing as defined under Goal (e) is executed in a thorough, fair and impartial manner.

**Appendix B –
IBOC DAB System Test Guidelines – Part I –
Laboratory Tests**



2500 Wilson Boulevard
Arlington, VA 22201-3834
(703) 907-7500
FAX (703) 907-7501

NATIONAL RADIO SYSTEMS COMMITTEE



1771 N Street, NW
Washington, DC 20036-2891
(202) 429-5346
FAX (202) 775-4981

(adopted 4/17/99)

DAB SUBCOMMITTEE IBOC DAB System Test Guidelines (Part I – Laboratory Tests)

Addendum #1 Additional Information on Data Formatting

This addendum provides additional information regarding data formatting of IBOC system data submission. Proponents intending to submit IBOC system performance data to the NRSC for evaluation are asked to consider the information in this addendum as they prepare their submission.

Recorded audio – the NRSC expects that proponents will use a variety of recording media for data collection including but not limited to digital audio tape (DAT) and digital recording directly onto hard disks and/or compact discs (CDs).

The preferred format for audio recording submission to the NRSC is linear CD audio with a sampling rate of 44.1 kHz. Use of the CD format minimizes or eliminates the possibility of alteration of the submitted material and allows the evaluators to make use of widely available, high-quality playback equipment. Alternatively, a proponent may elect to submit audio in DAT format.

The use of digital audio compression (for the purpose of bit rate reduction) at any point in the audio collection process would be inadvisable, and the NRSC assumes that the only digital audio compression existing in any submitted recordings is that of the IBOC perceptual audio coding system alone.

Computer-based data – in the event that a proponent submits data in computer form, it should be in “machine-readable” format, using tabs, commas, or quotation marks to delimit the different fields of data. Spaces may also be used as a delimiter in combination with the delimiters identified above or, when on ambiguity would result, alone. Data may also be presented in any format that can be imported into a Microsoft Excel spreadsheet.



2500 Wilson Boulevard
Arlington, VA 22201-3834
(703) 907-7500
FAX (703) 907-7501

NATIONAL RADIO SYSTEMS COMMITTEE



1771 N Street, NW
Washington, DC 20036-2891
(202) 429-5346
FAX (202) 775-4981

5/27/99

DAB SUBCOMMITTEE IBOC DAB System Test Guidelines (Part I – Laboratory Tests)

Addendum #2 Long-form audio

This addendum provides additional information regarding the “long-form” audio referred to in Section 4.2 of the Laboratory Test Guideline document.

The long-form audio material consists of 13 individual tracks and runs for approximately 62 minutes. Information on each track is provided in Table 1. This material was obtained directly from the mixing board output of the radio stations which contributed material, and did not undergo audio processing. It was recorded digitally and is available to interested proponents on request from the NRSC on compact disc (CD).

Table 1. NRSC long-form audio CD

Track	Station	Format	Length
1	WROR-FM 105.7 Boston	Oldies	3:52
2	WMJX-FM 106.7 Boston	Soft rock	6:47
3	WKLB-FM 99.5 Boston	Country	1:56
4	WBOS-FM 92.9 Boston	Rock	8:17
5	WSJZ-FM 96.9 Boston	Smooth jazz	3:05
6	WMGK-FM 102.9 Phila.	Classic hits	4:01
7	WXXM-FM 95.7 Phila.	Modern rock	3:42
8	WPEN-AM 950 Phila.	Nostalgia	3:38
9	WSJZ-FM 96.9 Boston (w/song)	Smooth jazz	7:22
10	WBOS-FM 92.9 Boston (w/song)	Rock	4:43
11	WMJX-FM 106.7 Boston (w/song)	Soft rock	4:50
12	WKLB-FM 99.5 Boston (w/song)	Country	4:04
13	WROR-FM 105.7 Boston (w/song)	Oldies	5:43



2500 Wilson Boulevard
Arlington, VA 22201-3834
(703) 907-7500
FAX (703) 907-7501

NATIONAL
RADIO

**IBOC DAB
SUBCOMMITTEE**



1771 N Street, NW
Washington, DC 20036-2891
(202) 429-5346
FAX (202) 775-4981

DAB SUBCOMMITTEE IBOC DAB System Test Guidelines (Part I – Laboratory Tests)

Addendum #3 NRSC broadcast chain - AM

This addendum provides additional information regarding the NRSC broadcast chain (for the AM broadcasting service) which is referred to in Section 4 of the Laboratory Test Guideline.

A volunteer AM station, WCGA-AM, St. Simons Island, Georgia, was used to create the NRSC broadcast chain (AM) audio. Two types of materials were recorded through this broadcast chain – critical audio materials (described on pg. 39 of the lab test guidelines) and “long-form audio materials (described in Addendum #2 to the lab test guidelines).

Figures 1 (transmit) and 2 (receive) contain a hardware description of this station as set up for NRSC broadcast chain recordings. The audio processor settings used at the transmit site are given in Tables 1 (light – used for critical audio materials) and 2 (moderate – used for long-form audio). In Figure 3, a spectrum plot of the AM signal as received is given.

In addition, there are two appendices to this addendum. Appendix 1 is a description of the test procedure followed in the making of the broadcast chain recordings; Appendix 2 contains characterization data on the receiver used (data obtained during the 1995 EIA/DAR laboratory testing of DAB systems).



2500 Wilson Boulevard
Arlington, VA 22201-3834
(703) 907-7500
FAX (703) 907-7501

NATIONAL RADIO SYSTEMS COMMITTEE



1771 N Street, NW
Washington, DC 20036-2891
(202) 429-5346
FAX (202) 775-4981

(draft 9/27/99)

DAB SUBCOMMITTEE IBOC DAB System Test Guidelines (Part I – Laboratory Tests)

Addendum #4 Inclusion of “Mode” signal in data report

This addendum provides additional information regarding specific data being requested for inclusion in an IBOC system data submission. Proponents intending to submit IBOC system performance data to the NRSC for evaluation are asked to consider the information in this addendum as they prepare their submission.

At the August 13, 1999 meeting of the Evaluation Working Group, a need was identified for a "mode" signal to be included as part of a proponents submission of test results. This group has determined that such information will be instrumental in characterizing the operation of IBOC systems which utilize different modes based on transmission conditions.

This mode signal would indicate the particular mode of an IBOC audio signal versus time (for example, as part of a field test run) or versus operating point (as in a laboratory adjacent channel test), and would be analogous to the stereo pilot indicator provided by an analog FM stereo receiver. This information would apply to all tests, i.e., the IBOC audio signal mode is of interest for all modes of operation and under any test conditions.

Based on the technical disclosures made by the current IBOC proponents, it is expected that for USA Digital Radio, the mode indicator would indicate when the IBOC audio had "blended to analog," and for Lucent Digital Radio, the number of streams actually being used in the multi-stream audio processing at the receiver (e.g., from 1 to 4 for their FM system). For Digital Radio Express, it is not presently known if a mode signal would be appropriate, however, DRE is requested to make this evaluation based on the needs of the NRSC as expressed herein and on the particulars of their system's design.

Proponents are also encouraged to submit any auxiliary information which would help to characterize the audio quality represented by a particular mode (as indicated by the mode signal), for example, by conducting subjective evaluations on data for which the mode signal information has been collected.



**NATIONAL
RADIO SYSTEMS
COMMITTEE**



D A B S u b c o m m i t t e e

**In-band/On-channel (IBOC)
Digital Audio Broadcasting (DAB)
System Test Guidelines**

Part I – Laboratory Tests

(as adopted by the Subcommittee on December 3, 1998)

Table of Contents

1	INTRODUCTION	4
2	PROPONENT SUBMISSIONS TO THE NRSC	6
3	DEFINITIONS	8
4	SUBJECTIVE EVALUATION GUIDELINES	10
4.1	FORMAL SUBJECTIVE EVALUATION.....	10
4.2	INFORMAL SUBJECTIVE EVALUATION.....	13
5	LABORATORY TEST GUIDELINES	15
5.1	FM-BAND PORTION	16
5.1.1	<i>Test A - System Calibration</i>	16
5.1.2	<i>Test B - IBOC system performance with AWGN</i>	16
5.1.3	<i>Test C - IBOC system performance with special impairments</i>	17
5.1.4	<i>Test D - IBOC “digital-to-digital” compatibility performance</i>	18
5.1.5	<i>Test E - IBOC “digital-to-digital” compatibility performance in a multipath fading channel</i>	18
5.1.6	<i>Test F - IBOC “digital-to-analog” compatibility performance</i>	19
5.1.7	<i>Test G - IBOC “digital-to-analog” compatibility performance in a multipath fading channel</i>	19
5.1.8	<i>Test H - IBOC “analog-to-digital” compatibility performance</i>	20
5.1.9	<i>Test I - IBOC “analog-to-digital” compatibility performance in a multipath fading channel</i>	20
5.1.10	<i>Test J - IBOC acquisition/reacquisition performance</i>	21
5.1.11	<i>Test K – DAB quality</i>	21
5.1.12	<i>Test L - IBOC “digital-to-host analog” compatibility performance</i>	22
5.1.13	<i>Test M - IBOC “host analog-to-digital” compatibility performance</i>	22
5.2	AM-BAND PORTION.....	24
5.2.1	<i>Test A - System Calibration</i>	24
5.2.2	<i>Test B - IBOC system performance with AWGN</i>	24
5.2.3	<i>Test C - IBOC system performance with special impairments</i>	24
5.2.4	<i>Test D - IBOC “digital-to-digital” compatibility performance</i>	25
5.2.5	<i>Test F - IBOC “digital-to-analog” compatibility performance</i>	25
5.2.6	<i>Test H - IBOC “analog-to-digital” compatibility performance</i>	26
5.2.7	<i>Test J - IBOC acquisition/reacquisition performance</i>	26
5.2.8	<i>Test K – DAB quality</i>	27
5.2.9	<i>Test L - IBOC “digital-to-host analog” compatibility performance</i>	27
5.2.10	<i>Test M - IBOC “host analog-to-digital” compatibility performance</i>	27

List of Appendices

APPENDIX A. RECOMMENDED LAB TEST OUTLINE – FM-BAND.....28

APPENDIX B. RECOMMENDED LAB TEST OUTLINE – AM-BAND.....42

APPENDIX C. ANALOG RECEIVER SELECTION (COMPATIBILITY TESTING)53

APPENDIX D. TEST MATRIX – LAB TEST GUIDELINES, FM-BAND PORTION56

APPENDIX E. TEST MATRIX – LAB TEST GUIDELINES, AM-BAND PORTION.....61

APPENDIX F. DAB SUBCOMMITTEE GOALS & OBJECTIVES64

APPENDIX G. IBOC STATUS REPORT (6/98).....66

List of Tables

TABLE 4-1 RECOMMENDED LEVELS OF AUDIO SUBJECTIVE EVALUATION – LABORATORY TESTS..... 14

TABLE 5-1. LABORATORY TEST GUIDELINES SUMMARY – IBOC SYSTEM, FM-BAND PORTION 15

TABLE 5-2. LABORATORY TEST GUIDELINES SUMMARY – IBOC SYSTEM, AM-BAND PORTION 15

List of Figures

FIGURE 1. ILLUSTRATION OF SUBJECTIVE EVALUATION PROCESS – UNIMPAIRED AUDIO QUALITY TESTING..... 11

FIGURE 2. ILLUSTRATION OF SUBJECTIVE EVALUATION PROCESS – IMPAIRMENT TESTING..... 12

1 Introduction

These test guidelines, developed by the Test Guideline Working Group (TGWG), Mr. Andy Laird, Chairman, of the DAB Subcommittee of the National Radio Systems Committee (NRSC), are the result of a cooperative effort between broadcasters, receiver manufacturers, and IBOC DAB system developers. Fundamentally, they describe the laboratory test results needed by the broadcasting and receiver manufacturing industries in order to assess the viability and desirability of proposed IBOC systems.

The development of these guidelines is perhaps the first substantive task undertaken by the DAB Subcommittee, since its re-activation in January of 1998, as it works towards fulfilling its goals and objectives as stated in Appendix F. Proponent submissions received by the NRSC which follow these guidelines can be expected to undergo a thorough review and analysis by the DAB Subcommittee, as it strives to determine whether or not submitted systems represent a significant improvement over the existing AM and FM analog radio transmission methods in use today, and otherwise appear to be viable IBOC DAB systems.

Unlike the prior DAB test program which the NRSC participated in, where multiple systems were tested simultaneously, these guidelines are designed to support independent testing of systems either by the proponents themselves (with third-party oversight, as discussed in Section 2) or by independent test contractors. In fact, the guidelines recognize that systems being designed by different organizations rarely develop according to the same schedule, and once developed, it is usually necessary to test them as quickly as possible so as to foster rapid deployment.

Given the open framework in which the NRSC conducts its activities, proponents can expect to be fully informed of the progress and direction of any evaluative efforts. Proponent participation is a vital aspect of this process, making it possible to be sure that any submissions are correctly interpreted and fairly judged. The NRSC looks forward to continued participation of the IBOC system proponents, as has been the case in the development of these test guidelines.

Included as an appendix to this test plan (Appendix G) is an article on the status of IBOC DAB as it existed at the time this test plan was drafted (presented at the Radio Montreux 1998 conference). This information is of interest since the technology and circumstances described therein had some influence on the formulation of the specific tests and procedures which appear in this document.

One aspect of current IBOC system development (referred to in Appendix F as "next-generation" systems) which was not in evidence in earlier developments ("first generation" systems, in Appendix G) was the so-called "all-digital IBOC" system design, which consists entirely of digital RF carriers and eliminates the analog AM or FM signal altogether. In recent Subcommittee deliberations, proponents have raised the issue of all-digital IBOC systems, and specifically, the integration of all-digital IBOC approaches with IBOC signals as they have been traditionally defined (consisting of both analog and digital carriers), as well as how the broadcasting industry might transition from traditional IBOC to all-digital IBOC.

The NRSC's sponsoring organizations (NAB and CEMA) have advised the DAB Subcommittee that for the purpose of the current investigations, traditional IBOC technology is

of paramount importance and that Subcommittee evaluations need to focus on these combined analog/digital IBOC signals.

Part II of these test guidelines, Field Tests, is currently under development. This document (Part I), combined with Part II when complete, fully defines the NRSC's requirements for IBOC system test results needed for its evaluative process to commence. Note that the release of these test guidelines documents in two parts is being done solely to help expedite the test process and *is not* meant to imply that submissions to the NRSC should be in two parts, as well. This guideline release schedule was selected to follow the natural progression of system development, which is from the laboratory into the field, and allows the NRSC to provide IBOC proponents with its test guidelines in the most timely fashion possible.

As fully explained in Section 2, proponent submissions are expected to be complete and include any and all laboratory and/or field test data which the proponent wishes the NRSC to consider.

2 Proponent Submissions to the NRSC

Proponents need to submit the following information to the NRSC in order for the DAB Subcommittee to be able to effectively evaluate their system:

- a) Detailed system description including:
 - i) High level description and theory of operation
 - ii) Transmission equipment description / requirements
 - iii) Receiver equipment description / requirements
 - iv) Compliance with (or changes necessary to) FCC rules

- b) Description of test procedures followed – note that Appendices A and B include suggested laboratory test procedures which are based on the experience gained by the NRSC in its prior DAB test efforts (Part II of these guidelines will include similar information for field testing). It is especially important that proponents electing to use test procedures which differ significantly from the suggested procedures provide detailed information on the procedures which were followed.

- c) Statement of oversight – proponents are expected to retain an independent, third-party observer (preferably an expert in broadcast and/or digital communications engineering) who will follow and/or review the system testing (done by the proponent) closely and personally certify the submitted results as an accurate record of the actual measured system performance. Alternatively, proponents may elect to make use of an independent system testing contractor for implementation of the test program.

This is a vital part of the proponent submission, which will allow the NRSC to evaluate with confidence the proponent-submitted data as an accurate depiction of performance.

- d) Test results obtained using procedures described in b) above. Proponents are strongly encouraged to follow the labeling and other conventions regarding test results established in this test guidelines document.

In accordance with DAB Subcommittee policy, data submissions (system descriptions, test procedures, test results, etc.) made by IBOC proponents to the NRSC for purposes of evaluation must be:

- on complete systems, that is, systems which provide for IBOC DAB in both the AM and FM bands. A submission made on a system which only operates in one of these bands will only be considered if, along with that submission, the proponent states its intention to *only* support IBOC operation in that single band, and furthermore, why they have elected not to develop a system which supports operation in both bands. Note that in such instances, the NRSC may elect not to evaluate the submission, in particular if submissions have been made by other proponents which support operation in both bands.

- made at the conclusion of the system development effort, that is, must represent the performance of a completed system. Test results taken on partially completed systems and/or preliminary results from (comprehensive) test programs will not be accepted, nor will multiple submissions (e.g., revised submissions) for a system already submitted.

Again, proponents are strongly encouraged to follow the NRSC IBOC System Test Guidelines (i.e. this document and Part II, Field Tests, when available) when preparing a submission, and indicate as part of their submission which desired test results (as stated in the Guidelines) are included. Appendices C and D (system test matrices) of this document were developed to serve as “checklists” which proponents can include with their submission, providing a straightforward way to indicate which requested test results have been obtained (similar checklists will be included in Part II).

3 Definitions

Acquisition/re-acquisition performance – the aspect of IBOC system performance characterized by the length of time needed to acquire (initially) or re-acquire (after an interruption in service) an IBOC transmission.

Analog main channel audio performance – performance (objective and/or subjective) of the analog main channel audio portion of a sound broadcasting transmission, either AM or FM, IBOC or (traditional) analog.

Bit Error Rate (BER) – a measure of digital system performance, simply, the ratio of the number of bits received in error, to the total number of bits received.

Co-channel signal – the RF signal co-located with, i.e. having the same center frequency as, a desired sound broadcasting signal. Note that the co-channel signal, for the purposes of IBOC DAB system evaluation, can be either a standard analog signal or an IBOC DAB signal.

Data transmission performance – performance of that portion of the IBOC system set aside for data transmission specifically (i.e. not used to carry the digital audio bit stream), typically characterized by BER, FER, etc. As used in Section 5 and unless otherwise indicated, this term refers to the performance of the “auxiliary” or “ancillary” data transmissions (terms often used by IBOC proponents and others to describe this portion of the system).

Desired signal – refers to a sound broadcasting signal (AM or FM, IBOC or non-IBOC) under test.

Digital audio performance – performance (objective and/or subjective) of the digital audio portion of the IBOC system.

First adjacent signal – the RF signal located either ± 200 kHz (for FM) or ± 10 kHz (for AM) away from the center frequency of a desired sound broadcasting signal. Note that the first adjacent signal, for the purposes of IBOC DAB system evaluation, can be either a standard analog signal or an IBOC DAB signal.

Frame – a particular segmentation of bits (or bytes) occurring within a system by virtue of some aspect of the system's design. For example, audio coding schemes such as PAC and MPEG-2 AAC format the coded digital audio data streams into frames of a specific definition, delineated by specific patterns of bits (e.g., headers, etc.) and with a predefined structure.

Frame Error Rate (FER) – a measure of digital system performance, simply, the ratio of the number of frames received in error, to the total number of frames received.

Host analog main channel audio performance – performance (objective and/or subjective) of the analog main channel audio portion of an IBOC system, considered to be the “host” to the IBOC digital carriers.

Host signal – the analog (AM or FM) sound broadcast signal which exists in the same channel as the digital portion of an IBOC DAB signal.

Host subcarrier performance – performance (objective and/or subjective) of the subcarrier (i.e.

SCA) signals associated with the analog carrier portion of an IBOC system (typically applies to FM systems only).

In-band/on-channel (IBOC) DAB – a method of digital audio broadcasting in which a digital audio signal is combined, in a mutually compatible fashion, with an existing analog audio signal (either AM or FM), in such a manner as to be consistent with the FCC rules (present or future) for AM and FM sound broadcasting.

Second adjacent signal – the RF signal located either ± 400 kHz (for FM) or ± 20 kHz (for AM) away from the center frequency of a desired sound broadcasting signal. Note that the second adjacent signal, for the purposes of IBOC DAB system evaluation, can be either a standard analog signal or an IBOC DAB signal.

Third adjacent signal – the RF signal located either ± 600 kHz (for FM) or ± 30 kHz (for AM) away from the center frequency of a desired sound broadcasting signal. Note that the third adjacent signal, for the purposes of IBOC DAB system evaluation, can be either a standard analog signal or an IBOC DAB signal.

Undesired signal – refers to a sound broadcasting signal (AM or FM, IBOC or non-IBOC), present along with a desired signal, as either a co-channel or adjacent channel signal.

4 Subjective evaluation guidelines

One of the most vital aspects of IBOC system evaluation involves subjective evaluation of the audio quality of the digital signal, in both unimpaired and impaired situations, as well as evaluation of the audio quality of analog audio signals affected by the presence of the IBOC digital signal energy. These analog signals include the IBOC host signal, co- and adjacent-channel standard analog (i.e. non-IBOC) signals, as well as the analog portion of co- and adjacent-channel IBOC signals.

4.1 Formal subjective evaluation

Within the general category of “formal” subjective evaluation of audio signals there are, for the purposes of this test guidelines document, two recommended approaches:

- TOA/POF determination – typically, when subjecting a signal to channel impairments (e.g., AWGN, co- and adjacent-channel interference), the threshold of audibility (TOA) and point of failure (POF) are subjectively determined by one or more expert listeners involved in the testing of the system.

TOA is defined as the system operating point (characterized by the impairment level, for example, the amount of AWGN, or the d/u ratio of a particular interfering signal) at which degradations in the audio are first detectable.

POF corresponds to the operating point where the audio signal just becomes so degraded as to be unusable, and is defined as a “1” on the ITU-R continuous 5-grade impairment scale (very annoying).

For submissions to the NRSC in which TOA/POF data are suggested (tests A-E, H, I, and M) proponents are expected to submit (along with the data) audio tapes with examples of audio determined to be at TOA and POF.

- Listening tests – for determining unimpaired audio quality, and in certain cases involving channel impairments, the audio quality of the system under test (“audio under test”) is recorded onto digital audio tape (DAT), and compared to a suitable audio “reference” by a panel of trained, expert listeners who assess the level of impairment of the audio under test (with respect to the reference). Procedures for conducting such listening tests have been standardized by the ITU and others.¹

In the particular case of unimpaired audio quality characterization, the NRSC has determined, for the purposes of its IBOC system evaluations, that the appropriate reference material to be used in a listening test of this sort is obtained by recording a digital audio source (CD or DAT) through an AM and possibly FM (for AM IBOC evaluation) or FM (for FM IBOC evaluations) broadcast signal chain, using an appropriate receiver. This process is illustrated

¹ Methods for the subjective assessment of Small Impairments in Audio Systems Including Multichannel Sound Systems, ITU-R Recommendation B.S.1116; Grusec, T., Thibault, L., & Soulodre, G. Subjective evaluation of high quality audio coding system: Methods and results in the two-channel case, *AES preprint 4065*, *AES 99th Convention*, October 6-9, 1995, New York.

conceptually in Figure 1, where it is emphasized that the subjective comparison does not involve the original digital audio source material.

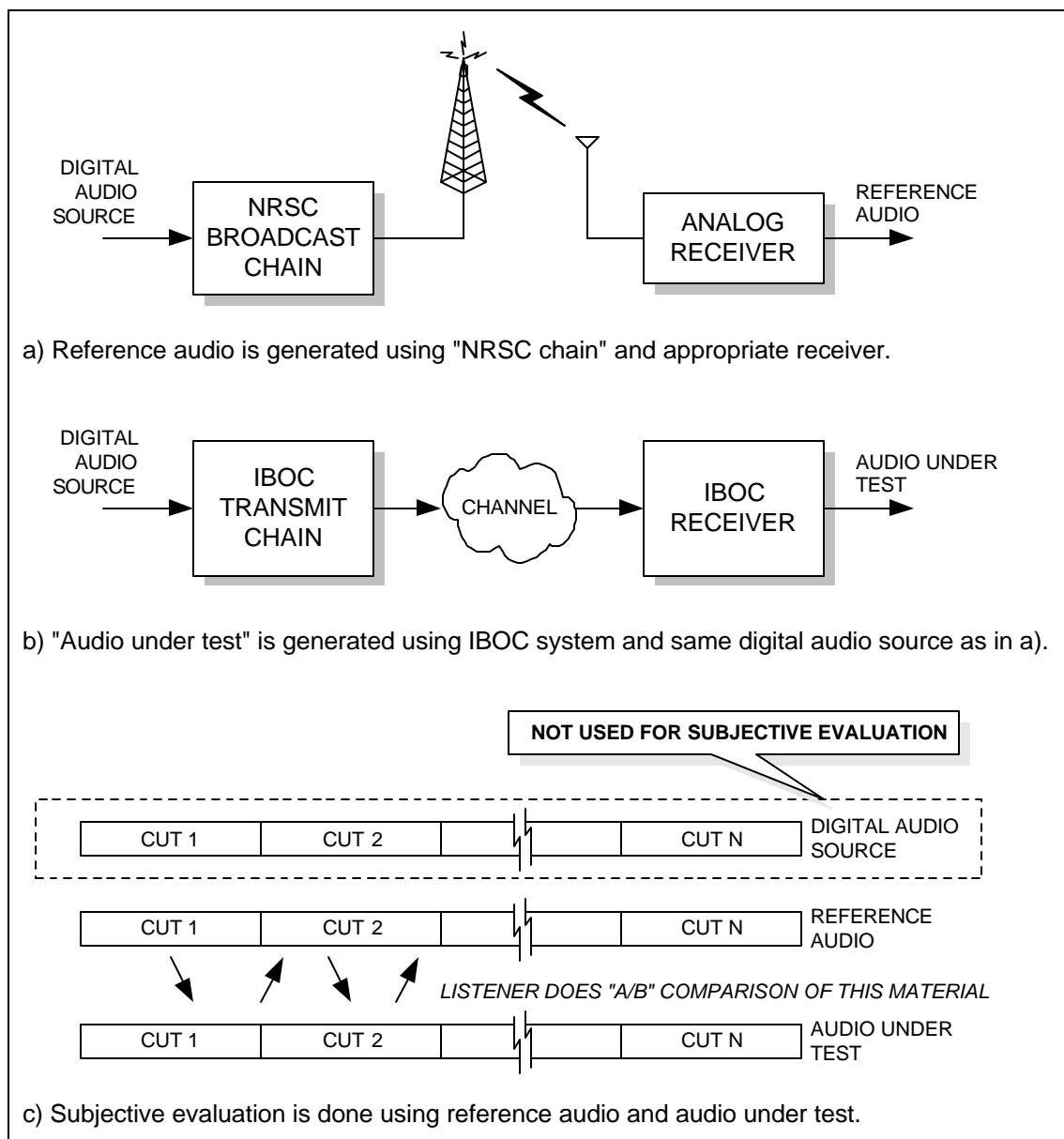

Figure 1. Illustration of subjective evaluation process – unimpaired audio quality testing

The NRSC has prepared DAT recordings of carefully selected audio materials, sent through processed and unprocessed AM and FM broadcast chains, then taken “off-air” using suitable receivers, for use as reference material in IBOC system evaluations, and will provide these tapes, along with the digital source material (in CD or DAT format), to proponents at their request, for use in IBOC system testing.

In the case of impairment tests, the process for obtaining an appropriate reference for subjective evaluation is illustrated conceptually in Figure 2. Note that for a particular set of tests

(e.g., Test F - digital to analog compatibility) the reference for each portion of the test (e.g., co-channel, 1st-adjacent, etc.) will in general be different, corresponding to the nature of the interference for each portion.

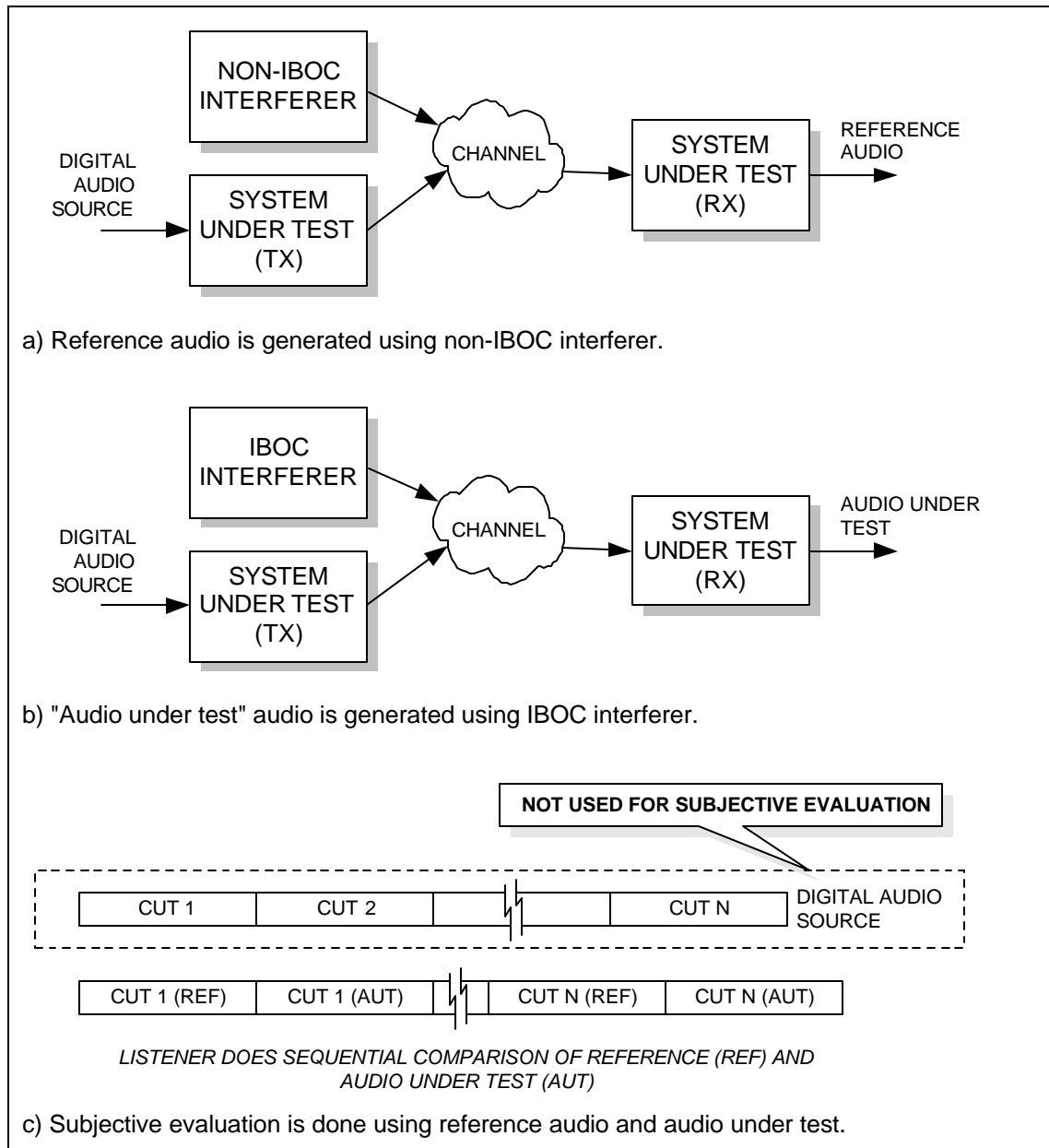

Figure 2. Illustration of subjective evaluation process – impairment testing

Also note that the subjective evaluation illustrated in Figure 2 is not an "A/B" test but instead consists of sequential comparisons of audio cuts. This method of testing was used by the NRSC in its earlier DAB test program, for subjective evaluation of impaired audio (not unimpaired quality testing), because of the sheer number of audio materials needing to be compared. In these cases, rather than using the continuous 5-grade impairment scale, a simpler 3-grade ("same as, better than, worse than" reference) scale was used. Data taken in

this manner, while departing somewhat from ITU-R recommendations, will be acceptable to the NRSC for impairment test results *only*.

For submissions to the NRSC in which listening test-type data are suggested (tests F, G, K, and L), proponents are expected to submit a detailed report which includes a description of how the listening tests were performed and by whom, the listening test results, and the audio tapes which were used to perform the listening tests.

Table 4-1 indicates the subjective evaluation approach being recommended by the NRSC for specific categories of IBOC system laboratory tests.

4.2 Informal subjective evaluation

While the guidelines for subjective evaluation just presented offer a scientific basis for judging the digital audio quality of proposed systems, the results thus obtained lack a “real-world” quality which broadcasters and receiver manufacturers also need in order for a thorough assessment of audio quality to be conducted.

Consequently, the NRSC has prepared a “long-form” digital audio tape (DAT) containing audio material representative of the many different programming “formats” that radio broadcasters’ utilize. This long-form audio, including announcer voice-overs, “jingles,” and the like, will be provided to IBOC proponents expressing an interest in having the NRSC evaluate their systems. A DAT tape of this material, as received by the IBOC system in an unimpaired environment, should then be submitted to the NRSC along with the more formal subjective evaluation material.

In this manner, the NRSC will have an opportunity to listen to digital audio as if it were being used for a real broadcast, and perhaps get more of a “feel” for the IBOC system audio quality than is possible by listening to the audio materials used in the more critical subjective evaluations alone.

Table 4-1 Recommended levels of audio subjective evaluation – laboratory tests

Test	Description	Subjective evaluation				Comments
		Audio under test	TOA, POF	Listening tests	Reference audio	
A	System calibration	IBOC digital	✓			
B	Performance with AWGN	IBOC digital	✓			
C	Performance with special impairments	IBOC digital	✓			Impairments include impulse noise, airplane flutter, weak signal, et.al.
D	D→D compatibility, linear channel	IBOC digital	✓			
E	D→D compatibility, multipath channel †	IBOC digital	✓			
F	D→A compatibility, linear channel	Std. analog (non-IBOC signal)		✓	Through system (non-IBOC interferer) – see Figure 2	Different reference material used for each case (e.g., co-channel, 1st-adj. chnl., etc.)
G	D→A compatibility, multipath channel †	Std. analog (non-IBOC signal)		✓	Through system (non-IBOC interferer) – see Figure 2	Different reference material used for each case (e.g., co-channel, 1st-adj. chnl., etc.)
H	A→D compatibility, linear channel	IBOC digital	✓			
I	A→D compatibility, multipath channel †	IBOC digital	✓			
J	Acquisition/reacquisition performance	n/a				
K	DAB quality	IBOC digital		✓	NRSC broadcast chain reference DAT – see Figure 1	Recommend unprocessed FM DAT for FM IBOC ref.; processed FM DAT and/or processed AM DAT for AM IBOC ref.
L	D→Host analog compatibility	Host analog		✓	Host analog performance with IBOC digital carriers disabled	
M	Host analog→D compatibility	IBOC digital	✓			

† Test not performed for AM IBOC

5 Laboratory test guidelines

Table 5-1 and Table 5-2 below summarize the laboratory test guidelines for IBOC systems (FM-band and AM-band portions, respectively). Note that the designations in the TEST NO. field (in each table) correspond to the test designations used in the EIA/NRSC DAR tests performed in the 1994-96 time frame.

Proponents are referred to Appendices A and B which contain suggested test procedures for laboratory tests. These procedures are recommended but not required, and are based on the test procedures used by the EIA/NRSC in its earlier evaluation of DAB systems.

Table 5-1. Laboratory Test Guidelines Summary – IBOC system, FM-Band portion

SECTION	TEST NO.	DESCRIPTION	COMMENTS
5.1.1	A	Calibration	
5.1.2	B	Impairment tests for characterization of DAB signal failure	
5.1.3	C	DAB with special impairments	
5.1.4	D	DAB → DAB	
5.1.5	E	DAB → DAB with multipath	
5.1.6	F	DAB → analog	
5.1.7	G	DAB → analog with multipath	
5.1.8	H	Analog → DAB	
5.1.9	I	Analog → DAB with multipath	
5.1.10	J	DAB acquisition and reacquisition	
5.1.12	K	DAB quality	
5.1.13	L	DAB → host analog	
5.1.13	M	Host analog → IBOC digital	

Table 5-2. Laboratory Test Guidelines Summary – IBOC system, AM-Band portion

SECTION	TEST NO.	DESCRIPTION	COMMENTS
5.2.1	A	Calibration	
5.2.2	B	Impairment tests for characterization of DAB signal failure	
5.2.3	C	DAB with special impairments	
5.2.4	D	DAB → DAB	
5.2.5	F	DAB → analog	
5.2.6	H	Analog → DAB	
5.2.7	J	DAB acquisition and reacquisition	
5.2.8	K	DAB quality	
5.2.9	L	DAB → host analog	
5.2.10	M	Host analog → IBOC digital	

5.1 FM-band portion

5.1.1 Test A - System Calibration

Purpose: To constantly maintain IBOC system hardware and associated test equipment in a known, calibrated state, and to establish clear and complete documentation of that state.

Desired results:

- 1) Average and peak RF power measurements of IBOC signal;
- 2) RF spectrum plot showing shape and spectral occupancy of IBOC signal;
- 3) Digital audio subjective performance baseline—using “Threshold of Audibility” (TOA) or some other subjective criteria—versus AWGN (linear channel);
- 4) Baseline characterization of system digital performance, both digital audio and data transmission paths (BER, FER, or other similar parameter) versus AWGN (linear channel);
- 5) Analog proof-of-performance test results (frequency response, distortion characteristics of main channel audio, etc.);
- 6) Calibration record of equipment used for testing.

Comments:

- Systems should be calibrated regularly to insure precise and accurate test data;
- Suggested settings for RF spectrum plots – RES BW 1 kHz, VBW 30 Hz, sweep span 500 kHz;
- Multiple data points (BER, FER, etc.) should be collected so as to allow for performance versus carrier-to-noise ratio data plots;
- Calibration records should be signed and dated.

5.1.2 Test B - IBOC system performance with AWGN

Purpose: To accurately and precisely characterize the **digital audio** and **data transmission** performance of the IBOC system in the presence of AWGN in both linear and simulated multipath fading channels, both with and without a 1st-adjacent IBOC FM interferer present.

Desired results: Digital audio, data transmission performance versus:

- 1) AWGN, linear channel, no adjacent channel signals;
- 2) AWGN, linear channel, with 1st-adjacent channel interferer;
- 3) AWGN, simulated multipath fading channel, no adjacent channel signals;
- 4) AWGN, simulated multipath fading channel, with 1st-adjacent channel interferer.

Comments:

- For each case, objective data (e.g., BER, FER, etc.) on both digital audio and data transmission paths, and subjective data (e.g., TOA, POF, etc.) on digital audio desired;
- Multiple data points (BER, FER, etc.) should be collected so as to allow for performance versus carrier-to-noise ratio data plots;
- 1st-adjacent channel interference cases performed with upper and lower interferers (individually); suggested D/U ratios are 0, +6 dB, +12 dB, and +18 dB;
- Suggested subjective evaluation procedure: refer to EIA DAR Laboratory test report, August 11, 1995;

- Suggested noise measurement procedure: refer to EIA DAR Laboratory Test Report, August 11, 1995, Appendix S;
- Suggested simulated multipath scenarios: refer to Appendix A.

5.1.3 Test C - IBOC system performance with special impairments

Purpose: To accurately and precisely characterize the **digital audio** and **data transmission** performance of the IBOC system in the presence of the following special channel impairments, both with and without a 1st-adjacent IBOC FM interferer present:

- Impulse noise – simulates automobile environment;
- Susceptibility to narrowband noise;
- Airplane-flutter-type multipath;
- Weak signal – simulates reception failure as distance between transmitter and receiver increases;
- Delay spread/doppler-type multipath with short and long delays, and both slow and fast motion.

Desired results: Digital audio, data transmission performance versus (all cases – linear channel):

- 1) Impulse noise, no adjacent channel interferer;
- 2) Impulse noise, with 1st-adjacent channel interferer;
- 3) Susceptibility to narrowband noise, no adjacent channel interferer;
- 4) Susceptibility to narrowband noise, with 1st-adj. channel interferer;
- 5) Airplane flutter-type multipath, no adjacent channel interferer;
- 6) Airplane flutter-type multipath, with 1st-adjacent channel interferer;
- 7) Weak signal, no adjacent channel interferer;
- 8) Weak signal, with 1st-adjacent channel interferer;
- 9) Delay spread/doppler-type multipath, no adj. channel interferer;
- 10) Delay spread/doppler-type multipath, with 1st-adj. chan. interferer.

- Comments:
- For each case, objective data (e.g., BER, FER, etc.) on both digital audio and data transmission paths, and subjective data (e.g., TOA, POF, etc.) on digital audio desired;
 - Multiple data points (BER, FER, etc.) should be collected so as to allow for performance versus impairment level data plots;
 - 1st-adjacent channel interference cases performed with upper and lower interferers (individually); suggested D/U ratios are 0, +6 dB, +12 dB, and +18 dB;
 - Suggested impulse noise impairment parameters: pulse width - 10 nanoseconds; pulse rise and decay time - 3 to 4 nanoseconds; pulse repetition rate - 100 Hz to 1000 Hz, including 120 Hz;
 - Suggested narrowband noise parameters: signal source – FM signal w/5 kHz deviation modulated with white noise; signal location – from 60 kHz below IBOC digital carriers to 60 kHz above, in 20 kHz increments;
 - Suggested airplane flutter scenarios:
 - 400 Km/h, delay 27.5 usec, attenuation 8 dB;
 - 200 Km/h, delay 18.7 usec, attenuation 6 dB;
 - 100 Km/h, delay 6.8 usec, attenuation 4 dB;
 - Refer to EIA DAR Laboratory Report (August 11, 1995) for suggested delay spread/doppler measurement techniques.

5.1.4 Test D - IBOC “digital-to-digital” compatibility performance

- Purpose: To accurately and precisely characterize the **digital audio** and **data transmission** performance of the IBOC system in the presence of co, 1st-adjacent, and 2nd-adjacent channel IBOC FM interference, in a linear channel. In the 2nd-adjacent case, the effect of a compressing linear amplifier (at the 1 dB compression point) in the RF signal chain should be characterized, as well.
- Desired results: Digital audio, data transmission performance versus (linear channel, except where noted):
- 1) Co-channel interference;
 - 2) Single 1st-adjacent channel interference (upper and lower, individually);
 - 3) Simultaneous upper and lower 1st-adjacent channel interference;
 - 4) Single 2nd-adjacent channel interference (upper and lower, individually);
 - 5) Single 2nd-adjacent channel interference (upper and lower, individually) with 1st-adjacent channel interferer present (upper and lower, individually – 4 cases in all);
 - 6) Simultaneous upper and lower 2nd-adjacent channel interference;
 - 7) Simultaneous upper and lower 2nd-adjacent channel interference with compressing linear amplifier in RF chain (operating at 1 dB compression point).
- Comments:
- For each case, objective data (*e.g.*, BER, FER, etc.) on both digital audio and data transmission paths, and subjective data (*e.g.*, TOA, POF, etc.) on digital audio desired;
 - Multiple data points (BER, FER, etc.) should be collected so as to allow for performance versus D/U ratio data plots;
 - Suggested method for establishing analog benchmark: perform analog FM to analog FM interference tests at same D/U ratios identified for digital TOA and POF and characterize analog performance (contact CEMA Engineering dept. to determine current preferred analog FM receivers);
 - For tests involving two simultaneous interferers, it is suggested that one be set to D/U ratios of 0, +6 dB, +12 dB, +18 dB, while the other then be varied to establish operating points of interest (*e.g.*, TOA, POF, etc.).

5.1.5 Test E - IBOC “digital-to-digital” compatibility performance in a multipath fading channel

- Purpose: To accurately and precisely characterize the **digital audio** and **data transmission** performance of the IBOC system in the presence of co, 1st-adjacent, and 2nd-adjacent channel IBOC FM interference, in a multipath fading channel. In the 2nd-adjacent case, the effect of a compressing linear amplifier (at the 1 dB compression point) in the RF signal chain should be determined, as well.
- Desired results: Refer to Test D for description of desired results – all cases identical except now using multipath fading channel simulations.
- Comments:
- For each case, objective data (*e.g.*, BER, FER, etc.) on both digital audio and data transmission paths, and subjective data (*e.g.*, TOA, POF, etc.) on digital audio desired;
 - Multiple data points (BER, FER, etc.) should be collected so as to allow for performance versus D/U ratio data plots;

- Suggested method for establishing analog benchmark: perform analog FM to analog FM interference tests at same D/U ratios identified for digital TOA and POF and characterize analog performance (contact CEMA Engineering dept. to determine current preferred analog FM receivers);
- For tests involving two simultaneous interferers, it is suggested that one be set to D/U ratios of 0, +6 dB, +12 dB, +18 dB, while the other then be varied to establish operating points of interest (*e.g.*, TOA, POF, etc.);
- Suggested simulated multipath scenarios: refer to Appendix A.

5.1.6 Test F - IBOC “digital-to-analog” compatibility performance

Purpose: To accurately and precisely characterize the ***analog main channel audio*** performance of the IBOC system in the presence of co, 1st-adjacent, and 2nd-adjacent channel IBOC FM interference, as experienced by a representative selection of commercially-available analog FM receivers.

Desired results: Analog main-channel audio performance, objective and subjective, versus (all cases linear channel):

- 1) Co-channel interference;
- 2) Single 1st-adjacent channel interference (upper and lower, individually);
- 3) Simultaneous upper and lower 1st-adjacent channel interference;
- 4) Single 2nd-adjacent channel interference (upper and lower, individually);
- 5) Single 2nd-adjacent channel interference (upper and lower, individually) with 1st-adjacent channel interferer present (upper and lower, individually – 4 cases in all);
- 6) Simultaneous upper and lower 2nd-adjacent channel interference.

Comments:

- Suggested objective characterization: D/U ratio required for main channel stereo audio S/N ratio of 35 dB and 50 dB (quasi-peak measurements);
- Suggested subjective evaluation procedure: refer to EIA DAR Laboratory test report, August 11, 1995;
- Contact CEMA Engineering dept. to determine current preferred analog FM receivers for use in analog compatibility tests;
- For tests involving two simultaneous interferers, it is suggested that one be set to D/U ratios of 0, +6 dB, +12 dB, +18 dB, while the other then be varied to establish operating points of interest (*e.g.*, TOA, POF).

5.1.7 Test G - IBOC “digital-to-analog” compatibility performance in a multipath fading channel

Purpose: To accurately and precisely characterize the ***analog main channel audio*** performance of the IBOC system, in a multipath fading channel, in the presence of co, 1st-adjacent, and 2nd-adjacent channel IBOC FM interference, as experienced by a representative selection of commercially-available analog FM receivers.

Desired results: Refer to Test F for desired results description – all cases identical except now using multipath fading channel simulations.

- Comments:
- Suggested objective characterization: D/U ratio required for main channel stereo audio S/N ratio of 35 dB and 50 dB (quasi-peak measurements);
 - Suggested subjective evaluation procedure: refer to EIA DAR Laboratory test report, August 11, 1995;
 - Contact CEMA Engineering dept. to determine current preferred analog FM receivers for use in analog compatibility tests;
 - Suggested simulated multipath scenarios: refer to Appendix A.
 - For tests involving two simultaneous interferers, it is suggested that one be set to D/U ratios of 0, +6 dB, +12 dB, +18 dB, while the other then be varied to establish operating points of interest (e.g., TOA, POF).

5.1.8 Test H - IBOC “analog-to-digital” compatibility performance

- Purpose: To accurately and precisely characterize the **digital audio** and **data transmission** performance of the IBOC system in the presence of 1st-adjacent, and 2nd-adjacent channel standard FM analog (i.e. non-IBOC FM) interference.
- Desired results: Digital audio, data transmission performance versus (all cases - linear channel):
- 1) Single 1st-adjacent channel interference (upper and lower, individually);
 - 2) Simultaneous upper and lower 1st-adjacent channel interference;
 - 3) Single 2nd-adjacent channel interference (upper and lower, individually).
- Comments:
- For each case, objective data (e.g., BER, FER, etc.) on both digital audio and data transmission paths, and subjective data (e.g., TOA, POF, etc.) on digital audio desired;
 - Multiple data points (BER, FER, etc.) should be collected so as to allow for performance versus D/U ratio data plots;
 - For tests involving two simultaneous interferers, it is suggested that one be set to D/U ratios of 0, +6 dB, +12 dB, +18 dB, while the other then be varied to establish operating points of interest (e.g., TOA, POF).

5.1.9 Test I - IBOC “analog-to-digital” compatibility performance in a multipath fading channel

- Purpose: To accurately and precisely characterize the **digital audio** and **data transmission** performance of the IBOC system in the presence of 1st-adjacent, and 2nd-adjacent channel standard FM analog (i.e. non-IBOC FM) interference, in a multipath fading channel.
- Desired results: Refer to Test H for description of desired results – all cases identical except now using multipath fading channel simulations. Also include additional test 4):
- 4) Simultaneous upper and lower 2nd-adjacent channel interference.
- Comments:
- For each case, objective data (e.g., BER, FER, etc.) on both digital audio and data transmission paths, and subjective data (e.g., TOA, POF, etc.) on digital audio desired;
 - Multiple data points (BER, FER, etc.) should be collected so as to allow for performance versus carrier-to-noise ratio data plots;

- For tests involving two simultaneous interferers, it is suggested that one be set to D/U ratios of 0, +6 dB, +12 dB, +18 dB, while the other then be varied to establish operating points of interest (*e.g.*, TOA, POF);
- Suggested simulated multipath scenarios: refer to Appendix A.

5.1.10 Test J - IBOC acquisition/reacquisition performance

Purpose: To accurately and precisely characterize the **acquisition/re-acquisition** performance of the IBOC system under weak signal conditions, in both linear and multipath fading channels, and in the presence of 1st-adjacent channel IBOC FM interference.

Desired results: IBOC system acquisition/re-acquisition performance versus:

- 1) Short interruption in signal (linear channel, no noise);
- 2) Long interruption in signal (linear channel, no noise);
- 3) Short interruption in signal (linear channel, with AWGN);
- 4) Long interruption in signal (linear channel, with AWGN);
- 5) Short interruption in signal (linear channel, no noise), with 1st-adjacent channel interference;
- 6) Long interruption in signal (linear channel, no noise), with 1st-adjacent channel interference;
- 7) Short interruption in signal (multipath fading channel, no noise);
- 8) Long interruption in signal (multipath fading channel, no noise);
- 9) Short interruption in signal (multipath fading channel, with AWGN);
- 10) Long interruption in signal (multipath fading channel, with AWGN);
- 11) Short interruption in signal (multipath fading channel, no noise), with 1st-adjacent channel interference;
- 12) Long interruption in signal (multipath fading channel, no noise), with 1st-adjacent channel interference;

Comments:

- Interruptions (short and long) must cause receiver to lose lock;
- Data points should be collected at a number of AWGN noise levels (as appropriate) to allow for performance versus carrier-to-noise ratio data plots;
- 1st-adjacent channel interference cases performed with upper and lower interferers (individually); suggested D/U ratios are 0, +6 dB, +12 dB, and +18 dB;
- Suggested simulated multipath scenarios: refer to Appendix A.

5.1.11 Test K – DAB quality

Purpose: To subjectively establish the unimpaired audio quality of the IBOC digital audio signal through a linear channel, and compare that performance to existing analog FM unimpaired audio quality.

Desired results:

- 1) Subjective evaluation report comparing IBOC digital audio quality (unimpaired, linear channel) with existing analog FM quality (unimpaired, linear channel);
- 2) "Long form" audio DAT recording through IBOC system (as described in Section 4.2).

- Comments:
- Recommended source and reference audio material: NRSC source and broadcast chain reference (refer to Section 4 for additional information);
 - Refer to Appendix A for suggested audio test segments;
 - DAT recordings used in subjective evaluations should also be included in submission to allow for review by NRSC.

5.1.12 Test L - IBOC “digital-to-host analog” compatibility performance

Purpose: To accurately and precisely characterize the **host analog main channel audio** and **host subcarrier** performance of the IBOC system in the presence of the IBOC digital signal, in both linear and multipath fading channels, as experienced by a representative selection of commercially-available analog FM and subcarrier receivers. Of particular interest is the effect of IBOC DAB on 92 kHz analog subcarrier signals, which are used extensively by public broadcasting stations in support of reading services for the blind.

Desired results: Host analog main-channel audio performance, objective and subjective, versus:

- 1) Presence or absence of IBOC digital signal energy, linear channel;
- 2) Presence or absence of IBOC digital signal energy, multipath fading channel.

Host subcarrier audio or data performance (as appropriate) versus:

- 3) Presence or absence of IBOC digital signal energy, linear channel;
- 4) Presence or absence of IBOC digital signal energy, multipath fading channel.

- Comments:
- Contact CEMA Engineering dept. to determine current preferred analog FM receivers for use in analog compatibility tests;
 - Suggested objective characterization: D/U ratio required for main channel stereo audio S/N ratio of 35 dB and 50 dB (quasi-peak measurements);
 - Suggested subjective evaluation procedure: refer to EIA DAR Laboratory test report, August 11, 1995;
 - Suggested FM subcarrier configuration: 3% RDS (57 kHz c.f.), 8.5% 67 kHz c.f. FM analog, and 8.5% 92 kHz c.f. FM analog.

5.1.13 Test M - IBOC “host analog-to-digital” compatibility performance

Purpose: To accurately and precisely characterize the **digital audio** and **data transmission** performance of the IBOC system in the presence of the host analog signal, in both linear and multipath fading channels.

Desired results: Digital audio, data transmission performance versus:

- 1) Percent modulation of the analog host signal, linear channel;
- 2) Percent modulation of the analog host signal, multipath fading channel.

- Comments:
- For each case, objective data (e.g., BER, FER, etc.) on both digital audio and data transmission paths, and subjective data (e.g., TOA, POF, etc.) on digital audio desired;
 - Multiple data points (BER, FER, etc.) should be collected so as to allow for performance versus percent modulation data plots;
 - Suggested FM subcarrier configuration (for analog host signal): 3% RDS (57 kHz c.f.), 8.5% 67 kHz c.f. FM analog, and 8.5% 92 kHz c.f. FM analog;

- Suggested subjective evaluation procedure: refer to EIA DAR Laboratory test report, August 11, 1995.

5.2 AM-band portion

5.2.1 Test A - System Calibration

Purpose: To constantly maintain IBOC system hardware and associated test equipment in a known, calibrated state, and to establish clear and complete documentation of that state.

Desired results:

- 1) Average and peak RF power measurements of IBOC signal;
- 2) RF spectrum plot showing shape and spectral occupancy of IBOC signal;
- 3) Digital audio subjective performance baseline—using “Threshold of Audibility” (TOA) or some other subjective criteria—versus AWGN (linear channel);
- 4) Baseline characterization of system digital performance (BER, FER, or other similar parameter) versus AWGN (linear channel);
- 5) Analog proof-of-performance test results (frequency response, distortion characteristics of main channel audio, etc.);
- 6) Calibration record of equipment used for testing.

Comments:

- Systems should be calibrated regularly to insure precise and accurate test data;
- Suggested settings for RF spectrum plots – in accordance with FCC rules, §73.44;
- Multiple data points (BER, FER, etc.) should be collected so as to allow for performance versus carrier-to-noise ratio data plots;
- Calibration records should be signed and dated.

5.2.2 Test B - IBOC system performance with AWGN

Purpose: To accurately and precisely characterize the **digital audio** and **data transmission** performance of the IBOC system in the presence of AWGN in a linear channel.

Desired results: Digital audio, data transmission performance versus:

- 1) AWGN, linear channel.

Comments:

- For each case, objective data (e.g., BER, FER, etc.) on both digital audio and data transmission paths, and subjective data (e.g., TOA, POF, etc.) on digital audio desired;
- Multiple data points (BER, FER, etc.) should be collected so as to allow for performance versus carrier-to-noise ratio data plots;
- Suggested subjective evaluation procedure: refer to EIA DAR Laboratory test report, August 11, 1995;
- Suggested noise measurement procedure: refer to EIA DAR Laboratory Test Report, August 11, 1995, Appendix S.

5.2.3 Test C - IBOC system performance with special impairments

Purpose: To accurately and precisely characterize the **digital audio** and **data transmission** performance of the IBOC system in the presence of the following special channel impairments:

- Impulse noise – simulates automobile environment;
- Weak signal – simulates reception failure as distance between transmitter and receiver increases.

Desired results: Digital audio, data transmission performance versus (all cases – linear channel):

- 1) Impulse noise;
- 2) Weak signal.

- Comments:
- For each case, objective data (e.g., BER, FER, etc.) on both digital audio and data transmission paths, and subjective data (e.g., TOA, POF, etc.) on digital audio desired;
 - Multiple data points (BER, FER, etc.) should be collected so as to allow for performance versus impairment level data plots;
 - Suggested impulse noise impairment parameters: pulse width - 100 nanoseconds; pulse rise and decay time - 3 to 4 nanoseconds; pulse repetition rate - 100 Hz to 1000 Hz , including 120 Hz.

5.2.4 Test D - IBOC “digital-to-digital” compatibility performance

Purpose: To accurately and precisely characterize the **digital audio** and **data transmission** performance of the IBOC system in the presence of co, 1st-adjacent, 2nd-adjacent, and 3rd-adjacent channel IBOC AM interference, in a linear channel.

Desired results: Digital audio, data transmission performance versus (linear channel, except where noted):

- 1) Co-channel interference;
- 2) Single 1st-adjacent channel interference (upper and lower, individually);
- 3) Simultaneous upper and lower 1st-adjacent channel interference;
- 4) Single 2nd-adjacent channel interference (upper and lower, individually);
- 5) Simultaneous upper and lower 2nd-adjacent channel interference;
- 6) Single 3rd-adjacent channel interference (upper and lower, individually);

- Comments:
- For each case, objective data (e.g., BER, FER, etc.) on both digital audio and data transmission paths, and subjective data (e.g., TOA, POF, etc.) on digital audio desired;
 - Multiple data points (BER, FER, etc.) should be collected so as to allow for performance versus D/U ratio data plots;
 - For tests involving two simultaneous interferers, it is suggested that one be set to D/U ratios of 0, +6 dB, +12 dB, +18 dB, while the other then be varied to establish operating points of interest (e.g., TOA, POF, etc.).

5.2.5 Test F - IBOC “digital-to-analog” compatibility performance

Purpose: To accurately and precisely characterize the **analog main channel audio** performance of the IBOC system in the presence of co, 1st-adjacent, and 2nd-adjacent channel IBOC AM interference, as experienced by a representative selection of commercially-available analog AM receivers.

Desired results: Analog main-channel audio performance, objective and subjective, versus (all cases linear channel):

- 1) Co-channel interference;
- 2) Single 1st-adjacent channel interference (upper and lower, individually);
- 3) Single 2nd-adjacent channel interference (upper and lower, individually).

- Comments:
- Suggested objective characterization: D/U ratio required for main channel stereo audio S/N ratio of 25 dB and 40 dB (quasi-peak measurements);
 - Suggested subjective evaluation procedure: refer to EIA DAR Laboratory test report, August 11, 1995;
 - Contact CEMA Engineering dept. to determine current preferred analog AM receivers for use in analog compatibility tests.

5.2.6 Test H - IBOC “analog-to-digital” compatibility performance

Purpose: To accurately and precisely characterize the **digital audio** and **data transmission** performance of the IBOC system in the presence of co-channel, 1st-adjacent, and 2nd-adjacent channel standard AM analog (i.e. non-IBOC FM) interference.

Desired results: Digital audio, data transmission performance versus (all cases - linear channel):

- 1) Co-channel interference;
- 2) Single 1st-adjacent channel interference (upper and lower, individually);
- 3) Simultaneous upper and lower 1st-adjacent channel interference;
- 4) Single 2nd-adjacent channel interference (upper and lower, individually);
- 5) Simultaneous upper and lower 2nd-adjacent channel interference.

- Comments:
- For each case, objective data (e.g., BER, FER, etc.) on both digital audio and data transmission paths, and subjective data (e.g., TOA, POF, etc.) on digital audio desired;
 - Multiple data points (BER, FER, etc.) should be collected so as to allow for performance versus D/U ratio data plots;
 - For tests involving two simultaneous interferers, it is suggested that one be set to D/U ratios of 0, +6 dB, +12 dB, +18 dB, while the other then be varied to establish operating points of interest (e.g., TOA, POF).

5.2.7 Test J - IBOC acquisition/reacquisition performance

Purpose: To accurately and precisely characterize the **acquisition/re-acquisition** performance of the IBOC system under weak signal conditions, in a linear channel.

Desired results: IBOC system acquisition/re-acquisition performance versus:

- 1) Short interruption in signal (linear channel, no noise);
- 2) Long interruption in signal (linear channel, no noise);
- 3) Short interruption in signal (linear channel, with AWGN);
- 4) Long interruption in signal (linear channel, with AWGN).

- Comments:
- Interruptions (short and long) must cause receiver to lose lock;
 - Data points should be collected at a number of AWGN noise levels (as appropriate) to allow for performance versus carrier-to-noise ratio data plots.

5.2.8 Test K – DAB quality

- Purpose: To subjectively establish the unimpaired audio quality of the IBOC digital audio signal through a linear channel, and compare that performance to existing analog AM unimpaired audio quality (and possibly FM audio quality as well).
- Desired results:
- 1) Subjective evaluation report comparing IBOC digital audio quality (unimpaired, linear channel) with existing analog AM quality (unimpaired, linear channel). Optionally, perform and report upon comparison of AM IBOC digital audio quality with FM analog audio quality;
 - 2) “Long form” audio DAT recording through IBOC system (as described in Section 4.2).
- Comments:
- Recommended source and reference audio material: NRSC source and broadcast chain reference (refer to Section 4 for additional information);
 - Refer to Appendix B for suggested audio test segments;
 - DAT recordings used in subjective evaluations should also be included in submission to allow for review by NRSC.

5.2.9 Test L - IBOC “digital-to-host analog” compatibility performance

- Purpose: To accurately and precisely characterize the **host analog main channel audio** performance of the IBOC system in the presence of the IBOC digital signal, in a linear channel, as experienced by a representative selection of commercially-available analog AM receivers.
- Desired results: Host analog main-channel audio performance, objective and subjective, versus:
- 1) Presence or absence of IBOC digital signal energy, linear channel.
- Comments:
- Contact CEMA Engineering dept. to determine current preferred analog AM receivers for use in analog compatibility tests;
 - Suggested subjective evaluation procedure: refer to EIA DAR Laboratory test report, August 11, 1995.

5.2.10 Test M - IBOC “host analog-to-digital” compatibility performance

- Purpose: To accurately and precisely characterize the **digital audio** and **data transmission** performance of the IBOC system in the presence of the host analog signal, in a linear channel.
- Desired results: Digital audio, data transmission performance versus:
- 1) Percent modulation of the analog host signal, linear channel.
- Comments:
- For each case, objective data (e.g., BER, FER, etc.) on both digital audio and data transmission paths, and subjective data (e.g., TOA, POF, etc.) on digital audio desired;
 - Multiple data points (BER, FER, etc.) should be collected so as to allow for performance versus percent modulation data plots;
 - Suggested subjective evaluation procedure: refer to EIA DAR Laboratory test report, August 11, 1995.

Appendix A. Recommended Lab Test Outline – FM-band

REVISION #13 October 8, 1998					
IBOC LABORATORY TEST GUIDELINES-FM BAND					
Test Group	Test & Impairment	TEST PROCEDURE Note: The audio impairment test material will be used for the TOA test (see test K).	Type of Evaluation	Signal Level	Test Results Data to be Recorded
A Calibration	1 Power (each test day or as needed)	1. IBOC analog and digital power will be read separately. 2. The digital average and peak power will be measured for each system at least once.	Objective	NA	Power level (average and peak)
	2 Spectrum (each test day or as needed)	1. A spectrum analyzer plot of the system RF spectrum will be taken for each test. 2. The spectrum analyzer settings will be: RES BW 1 kHz, VBW 30 Hz, and sweep span 500 kHz.	Objective	M	Spectrum plot
	3 TOA (daily or as needed)	Gaussian noise will be added to the signal in 0.25 dB steps until TOA occurs. Test C-4, weak signal, will also be conducted. For the FM systems that use diversity (two digital and FM), the TOA level will be found separately for each of the digital channels. Setting the composite level at -70 dBm, the analog S/N and stereo separation will be measured.	EO&C and Objective	M	TOA level (all)
	4 Audio recording (as needed)	An audio recording will be made of all of the proponent audio channels (analog and digital).	EO&C	M & W	Digital audio recording for the test record
	5 Proof IBOC (weekly)	During the analog compatibility tests, a proof of performance test will be conducted weekly on the analog portion of the proponent IBOC systems. A high quality demodulator will be used for this test.	Objective	Varying	Record of frequency response, separation, and distortion for the test record
	6 Reference analog TX total proof	If a reference transmitter is used, a proof of performance test will be conducted on this transmitter, with and without subcarriers, prior to the compatibility tests. Both subcarrier groups will be calibrated.	Objective	NA	Test records
	7 Monitor calibration (weekly or as needed)	The analog modulation monitors will be calibrated weekly using Bessel nulls.	Objective	NA	Calibration results recorded in laboratory test record
	8 Test bed calibration (monthly)	All of the critical components in the test bed, including the multipath simulator, attenuators, combiners, filters, generators, and measuring instruments, will be calibrated on a monthly schedule.	Objective	NA	Calibration record in test record

Composite Signal Levels: Wweak -77 dBm
 Moderate -62 dBm
 Strong -47 dBm

REVISION #13 October 8, 1998		IBOC LABORATORY TEST GUIDELINES-FM BAND			
Test Group	Test & Impairment	TEST PROCEDURE	Type of Evaluation	Signal Level dBm	Test Results Data to be Recorded
		<p>Note:</p> <ol style="list-style-type: none"> The EBU SQAM CD Glockenspiel audio segment will be used for impairment test. The detailed procedure for noise measurements will be supplied. See Appendix S of the Digital Audio Radio Laboratory Tests Report, August 11, 1995 Clipped pink noise will be used for the host analog signal. The EIA DAR laboratory tests were conducted with nine desired signal paths (rays) and three undesired paths as specified in Appendix E (VHF RAYLEIGH 9 PATH SIMULATION) of the August 11, 1995 report. When using a single six-channel MP simulator, only the desired channel will be effected by multipath. The six strongest paths will be selected from the nine for the six-path simulation. 			
B Impairment tests for characterization of DAR signal failure	1. Noise	<ol style="list-style-type: none"> Gaussian noise will be increased to TOA & POF (0.25 dB steps) and the levels logged. From the TOA the noise will be increased in 0.5 dB steps until the noise is 0.5 dB beyond POF. For each 0.5 dB step a digitally recording will be made for expert subjective assessment. Steps #1 & #2 will be repeated for each of the three impairment audio segments. The noise test will be repeated with an individual first adjacent upper and lower undesired analog FM signal. The first adjacent D/U will be set for +18 dB, +12 dB, +6 dB, and 0 dB. The undesired modulation will be processed program material. 	EO&C	M	Noise level at TOA & POF for all tested modes
	2. Multipath with noise	<ol style="list-style-type: none"> This test will be conducted four times, each with different Rayleigh multipath scenarios. <i>The</i> multipath scenarios will be those specified by the channel characterization sub-group of the DAR subcommittee. The RF level at the output of the MP simulator will be adjusted to compensate for variations in average signal level for each scenario. Without noise added to the composite IBOC signal, each of the multipath signal scenarios will be assessed in the transmission laboratory for impairments. For those systems where no impairment is heard, noise will be added to the signal in 0.5dB steps until the TOA and POF are found. For those systems where impairments are heard, the RF level will be increased in 1 dB steps until the audio impairments have ceased or the level has been increased by 10 dB. For those systems that require noise to be added to hear multipath, seven digital audio recordings will be made at the following noise levels: 1 dB below TOA, 0.5 dB below TOA, 0.5 dB above TOA, at six equal points between TOA and POF, and at POF. These digital recordings are for expert subjective assessment. The recordings will be made at both signal levels. 	EO&C	M +	TOA & POF with multipath and noise for all test modes
	3. Multipath for diversity systems	<ol style="list-style-type: none"> For the systems that use digital diversity (systems with two complete digital signals extending into the first adjacent FM channel), the multipath tests will be repeated with an individual interfering FM signal on the upper and lower first adjacent channel. The D/U ratios will be set for +18 dB, +12 dB, +6 dB, and 0 dB. The first adjacent modulation will be processed audio (committee make recommendation). The test will be repeated with the impairment audio on the analog channel. 	EO&C	M +	MP performance of each digital signal and test mode

REVISION #13 October 8, 1998		IBOC LABORATORY TEST GUIDELINES-FM BAND			
Test & Impairment	TEST PROCEDURE Notes:	Type of Evaluation	Sig. Level	Test Results Data to be Recorded	
C DAR with special impairment	<p>1. The EBU SQAM CD Glockenspiel audio segment will be used for the impairment tests.</p> <p>2. The host analog modulation will be clipped pink noise.</p> <p>3. Test C will be repeated with an individual upper and lower first adjacent undesired signal. The D/U ratios will be set for +18 dB, +12 dB, +6 dB, and 0 dB. The first adjacent modulation will be processed audio (The ABBA cut from the EBU SQAM test CD).</p>				
	<p>1. A generator capable of generating 10 nanosecond wide pulses with a rise and decay time of 3 to 4 nanoseconds will be used for the test. Pulse rates between 100 Hz to 1000 Hz will be used. All systems will be tested with a 120 Hz signal.</p> <p>2. The pulse generator output will be mixed with the DAR signal.</p> <p>3. The amplitude of the pulses will be increased until the laboratory specialist hears the TOA.</p>	EO&C	M	Pulse amplitude in Volts P-P at TOA	
	<p>1. The undesired signal will be generated with a laboratory test signal generator, FM modulated (deviation 5 kHz) with noise.</p> <p>2. The undesired signal will be incremented at 20 kHz intervals from 60 kHz below the digital signal to 60 kHz above the signal.</p> <p>3. Starting at a low RF level, the undesired amplitude will be increased in 1 dB steps until the TOA is heard.</p>	EO&C	M	Variations in the sensitivity to noise at different frequencies in the digital channel.	
	<p>1. Tests will be conducted with two simulated aircraft speeds of less than 400 Km/h.</p> <p>2. The simulated reflected signal will be increased until the TOA or POF is heard by the lab specialist.</p> <p>3. Scenarios:</p> <ul style="list-style-type: none"> a. 400 Km/h, delay 27.5 usec, attenuation 8 dB b. 200 Km/h, delay 18.7 usec, attenuation 6 dB c. 100 Km/h, delay 6.8 usec, attenuation 4 dB 	EO&C	M	Multipath parameters at TOA & POF	
	<p>1. Starting with a medium signal level, the signal will be reduced to TOA & POF (0.25 dB steps).</p> <p>2. A single audio impairment recording will be used for this test.</p> <p>3. Characterize failure between TOA and POF in 0.5 dB steps.</p> <p>Note- weak signal test should be used to monitor the performance of the receiver hardware but should not be used to evaluate the proposed system.</p>	EO&C	Varying	Signal level at TOA & POF TOA to POF characterization	
5 Delay spread/doppler	<p>Systems will be tested with four simulated multipath and motion extremes:</p> <ul style="list-style-type: none"> 1. Flat or short multipath with slow and fast motion. 2. Long multipath with slow and fast motion. <p>Note: See DAR laboratory report August 11, 1995 for procedures.</p>	EO&C	M	Rated impairments with varying delay spreads and doppler	

REVISION #13 October 8, 1998		IBOC LABORATORY TEST GUIDELINES-FM BAND			
Test Group	Test Number and Impairment	TEST PROCEDURE Note: 1. Two additional IBOC transmitters supplied by each proponent will generate the undesired DAR signals. 2. The desired host analog signal will be modulated with clipped pink noise. 3. A single impairment audio will be used for these tests.	Type of Evaluation	Sig. Level	Test Results & Data to be Recorded
D DAR -> DAR	1 Co-channel	1. The undesired co-channel DAR signal will be increased until the TOA and POF are heard by the lab specialist (0.25 dB resolution). 2. Co-channel signal failure will be characterized in 0.25 dB steps from TOA to POF using the five-step CCIR impairment scale. 3. Using the TOA D/U parameters found in step #1, FM to FM interference tests will be conducted to establish the analog reference. EO&C comments comparing the FM performance with the digital will be made. All five receives used for the EIA DAR test will be used for the analog reference tests.	EO&C in Lab	M	D/U & levels at TOA & POF Co-channel failure characteristics
	2 Single first adjacent	1. The undesired lower first adjacent composite IBOC signal will be increased in 0.5 dB steps until the TOE and POF are found. If when a D/U of 6 dB is reached and no TOA is found, band pass filtered Gaussian noise will be added to the signal until TOA and POF are found. The level of the added noise will be recorded. 2. With an undesired upper first adjacent standard FM signal set to D/Us of 18.0 dB, 12.0 dB, 6.0 dB, and 0.0 dB, the undesired first lower adjacent signal will be increased in 0.5 dB steps until the TOA and POF are found. 3. The test will be repeated (steps 1 and 2) with an upper first adjacent undesired signal.	EO&C in Lab	W&M	D/U & levels at TOA & POF First adjacent failure characteristics
	3 Second adjacent	1. Steps 2 through 5 will be conducted with a minimum out-of-channel power. 2. The undesired lower second adjacent DAR signal will be increased in 0.5 dB steps until the TOA and POF are observed. 3. The above test will be repeated with an upper <u>first</u> adjacent analog signal set for a D/U of +18 dB, +12dB, +6 dB and 0 dB. 4. The test will be repeated (steps 2 and 3) with an upper second adjacent undesired signal. 5. Simultaneous upper and lower second adjacent tests will be conducted. 6. The second adjacent tests will be repeated with the undesired signal's out-of-channel power increased in 5 dB steps until TOA and POF are detected in the desired IBOC audio. 7. The tests will be conducted with a D/U of at least -40 dB.	EO&C in Lab	W&M	D/U & levels at TOA & POF Second adjacent D/U with and without out-of-band components

REVISION #13 October 8, 1998		IBOC LABORATORY TEST GUIDELINES – FM BAND			
Test Group	Test Number and Impairment	TEST PROCEDURE	Type of Evaluated	Sig. Level	Test Results & Data to be Recorded
		Note: 1. The desired DAB signal will be modulated with the unprocessed impairment test audio sequences. 2. Clipped pink noise will be used for the host analog modulation.			
E DAR -> DAR with multipath	1 Co-channel	1. This test will be conducted four times, each with different multipath scenarios specified by the DAR subcommittee. 2. Without the undesired signal added, the transmission laboratory specialist will observe each of the multipath scenarios. 3. If impairments are heard no further testing will be conducted. 4. For those multipath tests where no impairment are heard, the undesired interference will be increased to the signal until TOA and POF interference levels are heard. 5. The D/U at TOA and POF will be recorded in the laboratory log. 6. Using the TOA D/U parameters found in step #5, FM to FM interference tests will be conducted to establish the analog reference. EO&C comments comparing the FM performance with the digital will be made. The Delco & Ford receivers used for the EIA DAR test will be used for the analog reference tests.	EO&C in Lab	M	D/U at TOA and POF levels for each undesired signal and multipath scenarios
	2 First adjacent	Same as Co-channel Test, E-1. 1. This test will be conducted on both the upper and lower first adjacent channels. 2. The test will be repeated with simultaneous upper and lower first adjacent undesired signals.	EO&C in Lab	W&M	D/U at TOA and POF levels for each undesired signal and multipath scenarios Audio recordings
	3 Second adjacent	Same as Co-channel Test, E-1. 1. This test will be conducted on both the upper and lower second adjacent channels. 2. The test will be repeated with simultaneous upper and lower second adjacent undesired signals.	EO&C in Lab	W&M	D/U at TOA and POF levels for each undesired signal and multipath scenarios Audio recordings

REVISION #13 October 8, 1998		IBOC LABORATORY TEST GUIDELINES - FM BAND			
Test Group	Test & Impairment	TEST PROCEDURE	Type of Evaluation	Desired Signal Level	Test Results Data to be Recorded
		Notes: 1. These tests will compare the IBOC to analog with the analog to analog interference. 2. If the proponent systems maintain digital signals that are more than 114 kHz from the host FM channel center frequency, further co-channel tests are unnecessary. The IBOC host FM signal will be the predominate interferer to the co-channel FM tests.			
F	<u>1 Co-channel objective</u>	See note 2 above	NA	NA	
DAR -> Analog (interference to an analog receiver with no other impairments)	<u>2 1st adjacent</u>	1. The five FM stereo receivers characterized in test L will be used for the FM band tests. 2. The desired FM transmitters will be set for 75 kHz deviation. The signal will be modulated with pilot. 3. The CCIR recommendation 412-4 weighting filter will be used for the program channel S/N measurements. A 19 kHz LP pilot filter will be used for the noise tests. 4. Increasing the undesired signal until the resulting audio signal/noise ratios are 35 and 50 dB (QPK), the D/U will be measured for the interference combinations: analog -> analog, and the DAR -> analog.	Objective	M	D/U at specified S/N for A -> A and D -> A
	<u>3 2nd adjacent</u>	1. The second adjacent channel tests are the same as the first-adjacent tests. The first and second adjacent channel measurement will be made both above and below the desired signal frequency.	Objective	M	D/U at specified S/N for A -> A and D -> A
	<u>4 Co-channel</u>	<i>See note 2 above.</i>	NA	NA	
	<u>5 1st adjacent</u>	1. The receivers used in step F.2.1 will be used for the subjective tests. 2. This test will be conducted with +16 dB, +6 dB, and 0 D/U. 3. Classical music, rock music, and silence will be used for the desired channel analog audio. 4. The reference will be analog to analog interference at 6 dB D/U. 5. The reference and the test will be recorded on digital tape for demonstration or evaluation.	Subjective EO&C	M	Recordings for industry evaluation
	<u>6 2nd adjacent</u>	1. Same as first adjacent Test F.5, with the second adjacent D/U set at -20 dB and -40 dB.	Subjective EO&C	M	Recordings for industry evaluation

REVISION #13 October 8, 1998		IBOC LABORATORY TEST GUIDELINES-FM BAND			
Test Group	Test	Test Description Notes: 1. The undesired DAR audio signals will be processed rock music.	Type of Eval.	Desired Signal Level	Test Results & Data to be Recorded
G DAR -> analog with multipath Interference to an analog receiver with multipath on the desired and undesired signals	1 Co-channel Subjective	See F-1	Subjective & EO&C	M	NA
	2 First Adjacent	1. This test will be conducted using the urban slow and urban fast multipath scenarios. The scenarios are those specified by the DAR subcommittee. 2. The five FM stereo receivers used in test L will be used. 3. The desired audio signal will be a moderately processed FM stereo signal. 4. The desired programming will be classical music, silence, and spoken voice. 5. The desired FM channel will be set for 75 kHz deviation with 1 kHz tone, pilot, and subcarriers (SC group A). 6. The FM band tests will subjectively evaluate the difference between the analog -> analog for reference and DAR -> analog set at a 6 dB D/U. 7. This test will be digitally recorded for further evaluation. Note: The first and second adjacent channel measurements will be made above and below the desired signal and averaged.	Subjective & EO&C	M	EO&C and subjective evaluation with the first adjacent 6 dB D/U.
	3 Second Adjacent	The second adjacent tests are the same as the first adjacent test G-2 with a -40 dB D/U in G2.6.	Subjective & EO&C	M	EO&C and subjective evaluation with -40 dB D/U.

REVISION #13 October 8, 1998		IBOC LABORATORY TESTS GUIDELINES - FM BAND			
Test Group	Test & Impairment	TEST PROCEDURE	Type of Evaluation	Desired Signal Level	Test Results Data to be Recorded
		Note: 1. The undesired analog signal will be modulated with processed rock stereo. 2. The host analog will be modulated with clipped pink noise.			
H	<u>1 Co-channel</u>	The host analog to digital test should provide all the data for co-channel performance.	NA	NA	
Analog -> DAR (no other impairments)	<u>2 1st adjacent</u>	1.The undesired lower 1st adjacent analog standard FM signal will be increased in 0.5 dB steps until the TOA and POF are found. If when a D/U of 6 dB is reached no impairments are heard, band pass filtered Gaussian noise will be added to the signals until TOA and POF are found. The level of the added noise will be recorded. 2.With an undesired upper 1st adjacent standard FM signal set to D/Us of +18.0, +12.0, + 6.0, and 0.0 dB, the undesired 1st lower adjacent signal will be increased in 0.5 dB steps until the TOA and POF are found. 3.This test will be repeated (steps 1 and 2) with an upper 1st adjacent undesired signal.	EO&C in lab	M	D/U at TOA & POF. Or Performance with 1st adjacent interference
	<u>3 Simultaneous upper and lower 1st adjacent</u>	1.Simultaneous upper and lower 1st adjacent analog signals will be increased until the TOA and POF are heard (0.5 dB steps).	EO&C in lab	M	D/U at TOA & POF.
	<u>4 2nd adjacent</u>	Note – this test will be conducted on both upper and lower 2nd adjacent channels. 1. The undesired analog signal will be increased until the TOA and POF are observed (1.0 dB steps). 2. Simultaneous upper and lower second adjacent tests will be conducted. The test will be conducted with a D/U of at least –40 dB.	EO&C in lab	M	D/U at TOA & POF

REVISION #13 October 8, 1998		IBOC LABORATORY TEST GUIDELINES-FM BAND			
Test Number and Impairment	TEST PROCEDURE	Type of Evaluation	Sig. Level	Test Results & Data to be Recorded	
	<p>Note:</p> <ol style="list-style-type: none"> The FM signal will be modulated with processed rock stereo and subcarrier group A. The DAB signal will be modulated with the impairment test audio. The host FM signal will be modulated with clipped pink noise. If clipped pink noise is heard during any of these tests, the test will be repeated with the impairment audio simultaneously modulating the digital and host analog channels. These tests will be conducted with the urban slow and urban fast multipath scenarios. The multipath scenarios will be those specified by the channel characterization sub-group of the DAR subcommittee. The RF level at the output of the MP simulator will be adjusted to compensate for variations in average signal level. Both the desired and undesired signals will be modulated with simulated multipath. 				
I Analog -> DAR with multipath	1 Co-channel MP	1. The host analog to digital test (M-2) should provide the data needed for co-channel performance.	NA	NA	NA
	2 First adjacent with multipath	<ol style="list-style-type: none"> The undesired signal will be increased to TOA and POF for both multipath scenarios (0.5 dB steps). For the systems that use diversity digital channels, the TOA may not be heard. In these cases the D/U will be set at 6 dB and a digital audio recording made of the IBOC received signal with each multipath scenario. This test will be conducted on both upper and lower first adjacent channels. 	EO&C in lab	M	D/U at TOA & POF with multipath Audio assessment without TOA.
	3 Simultaneous upper and lower first adjacent with multipath	<ol style="list-style-type: none"> Both the undesired signals will be increased to TOA and POF levels found with both multipath scenarios (0.5 dB steps). For the systems that use diversity digital channels, the TOA may not be heard. In these cases the D/U will be set at +6 dB and a digital audio recording made of the IBOC received signal for each multipath scenario. 	EO&C in lab	M	Same as I-2
	4 Second adjacent with multipath	<ol style="list-style-type: none"> The undesired signals will be increased to TOA and POF for both multipath scenarios (0.5 dB steps). For the systems that use diversity digital channels, the TOA may not be heard. In these cases the D/U will be set at -40 dB and a digital audio recording made of the IBOC received signal with each multipath scenario. This test will be conducted on both upper and lower first adjacent channels. 	EO&C in lab	M	Same as I-2
	5 Simultaneous upper and lower second adjacent with multipath	<ol style="list-style-type: none"> Both the undesired signals will be increased to TOA and POF levels found with both multipath scenarios (0.5 dB steps). For the systems that use diversity digital channels, the TOA may not be heard. In these cases the D/U will be set at -40 dB and a digital audio recording made of the IBOC received signal with each multipath scenario 	EO&C in lab	M	Same as I-2

REVISION #13 October 8, 1998		IBOC LABORATORY TEST GUIDELINES – FM BAND			
Test Group	Test & Impairment	TEST PROCEDURE	Type of Evaluation	Desired Signal Level	Test Results Data to be Recorded
		<p>Note:</p> <ol style="list-style-type: none"> The impairment audio will be Mozart track 67 on the SQAM disk. The host analog channel will be modulated with clipped pink noise. If clipped pink noise is heard during the test, the test will be repeated with the impairment audio simultaneously transmitted on the digital and host analog channels. Each test will be repeated at least five times and the results averaged. 			
J DAR acquisition and reacquisition tests	<u>1 Simulated weak signal failure and acquisition</u>	<ol style="list-style-type: none"> Noise will be added to the signal in 0.25 dB steps until POF is found. The POF level will be recorded. The DAR transmitter will be disconnected from the receiver for one (1) second to assure loss of lock. The test will be repeated with the transmitter disconnected from the receiver for thirty (30) seconds to assure loss of lock. Three tests will be conducted with the noise reduced in 2dB, 4dB, & 6 dB steps below POF for each test. The signal will be reconnected to the DAR receiver, and acquisition time will be recorded for each noise level. Acquisition is audio with some impairments. The reproduced audio will be graded using the CCIR five-point impairment scale. This test series will be repeated with an analog interferer on the upper and lower first adjacent channels set for D/U ratios of +18 dB, +12 dB, +6 dB, and 0 dB. The undesired first adjacent channel will be modulated with processed audio. 	EO&C in lab	M	Acquisition time at each noise level and disconnect time.
	<u>2 Simulated acquisition with multipath and noise</u>	<ol style="list-style-type: none"> This test will be conducted four times, each with different multipath scenario. The multipath parameters will be those specified by the DAR channel characterization sub-group. Noise will be added until the signal fails. The DAR transmitter will be disconnected from the receiver to assure loss of lock for one second. The test will be repeated with the signal broken for 30 seconds. A different scenario will be selected. For each of the multipath scenarios, three tests will be conducted with the noise reduced to 2dB, 4dB, & 6 dB below POF for each test. The signal will be reconnected to the DAR receiver and acquisition time recorded for each of the test parameters in step #5. Acquisition is the reproduction of listenable music. The audio quality will be graded during the acquisition cycle. This test series will be repeated with an analog interferer on the upper and lower first adjacent channels set for D/U ratios of +18 dB, +12 dB, +6 dB, and 0 dB. The undesired first adjacent channel will be modulated with processed audio. 	EO&C in lab	M	Acquisition time at each noise level, MP scenario, and disconnect time.

REVISION #13		IBOC LABORATORY TEST GUIDELINES-FM BAND			October 8, 1998
Test Group	Test Number and Impairment	Test Description	Type of Evaluation	Sig. Level	Test Results & Data to be Recorded
K DAR quality	1. Audio test segments Quality Impairment	1. The nine quality segments selected by the DAR Subcommittee will be used for the quality tests. 2. Glockenspiel will be used for the impairment tests.	NA	NA	NA
	2 Quality transmission test	1. The quality test materials selected in test K-1 will be transmitted through each DAR system and recorded digitally. 2. Each recorded segment will then be sent to a subjective assessment laboratory.	Subjective EO&C in Lab	M	Assessed using the ITU-R continuous 5-grade impairment scale (See Appendix U of the DAR Subcommittee Laboratory Tests)

Quality Audio Test Segments Selected by the DAR Subcommittee		
Description	Duration	Source
Dire Straits cut	30s	Warner Bros. CD 7599-25264-2 (track 6)
Pearl Jam cut	30s	Sony/Epic CD ZK53136 (track 3) with processing ¹
Sounds of water	30s	Roland Dimensional Space Processor Demo. CD
Glockenspiel	16s	EBU SQAM CD (track 35/Index 1)
Bass Clarinet arpeggio	30s	EBU SQAM CD (track 17/Index 1) with processing ¹
Music and rain	11s	AT&T mix
Susan Vega with glass	11s	AA&T mix
Muted trumpet	9s	Original DAT recording, University of Miami
Harpsichord arpeggio	12s	EBU SQAM CD (track 40/Index 1)

¹Processing chain used: Aphex Compellor Model 300 (set for leveling only)
Dolby Spectral Processor Model 740
Aphex Dominator II Model 720

REVISION #13		IBOC LABORATORY TEST GUIDELINES - FM BAND			October 8, 1998		
Test Group	Test & Impairment	TEST PROCEDURE			Type of Evaluation	Desired Signal Level	Test Results Data to be Recorded
		Notes: 1. Performance tests will be conducted for each of the five FM stereo compatibility receivers, including signal/noise, stereo separation/signal level, and sensitivity to narrowband noise. Narrowband noise tests will measure D/U at a fixed receiver S/N (45 dB QPK) using a noise modulated laboratory signal generator deviated 5 kHz, starting at the channel center frequency and extending to 266 kHz above and below the channel center frequency, in 38 kHz increments. 2. Analog program channel compatibility receiver noise tests will use quasi-peak detection and a CCIR weighting filter. The received audio will be routed through a 15kHz low pass filter.					
L	<u>1 IBOC to host analog</u>	1. Five representative FM stereo receivers will be used for the compatibility tests. 2. The host FM transmitters will be set for a total of 75 kHz deviation with 1 kHz tone. The host analog transmitter will be modulated with pilot. 3. For each of the compatibility receivers the audio S/N will be measured with and without the digital IBOC signal. The host FM to digital power ratio used in the performance test will be used for the compatibility tests. If the proponent elects to use multiple analog to digital ratios for the compatibility tests, the performance tests will also be conducted at these ratios.			Objective	S	FM audio S/N with and without
DAR -> Analog							
(IBOC host analog) ->	<u>2 IBOC to host analog</u>	1. The same receivers used for test L.1 will be used for this test. 2. The desired audio signal will be moderately processed. 3. Stereo classical music, rock music, silence, and spoken voice will be used for the audio. 4. The host and reference FM channels will be set for a total 75 kHz deviation with 1 kHz tone. 5. For each analog receiver test, a digital audio recording will be made of the host IBOC analog audio signal with the digital signal turned on and off.			Subjective EO&C	S	Recordings for further subjective assessment or demonstrations
	<u>3 IBOC to host analog with multipath</u>	1. The same receivers used for test L-1 will be used for this test. 2. Classical music, rock music, silence, and spoken voice will be used for the audio with moderate audio processing. 3. The four multipath scenarios selected by the RF channel characterization sub-group of the DAR subcommittee will be used. 4. For each test receiver, an EO&C report will compare the IBOC analog signal quality and the analog reference signal.			EO&C in lab & subjective	M	Digital audio recordings for further subjective assessment
	<u>4 IBOC to subcarriers</u>	1. Using a wideband precision demodulator, the baseband noise floor (100 Hz to 300 kHz) will be plotted with pilot, subcarriers (3% RBDS, 8.5% 67 kHz FM analog, and 8.5% 92 kHz FM analog), digital signal and 1 kHz tone on the program channel. The noise will again be plotted with the 1 kHz program audio tone removed. 2. The 92 kHz analog subcarrier RMS S/N will be measured with and without the 1 kHz tone on the main program channel. The 92 kHz Dayton receiver used in the 1995 DAR tests will be used.			Objective	M	Plot baseband noise floor change with IBOC digital signal, program modulation Any noise change in 92 kHz subcarrier

REVISION #13		IBOC LABORATORY TEST GUIDELINES-FM BAND			October 8, 1998
Test Group	Test	TEST PROCEDURE Note:	Type of Evaluation	Desired Signal Level	Test Results & Data to be Recorded
M Analog -> DAR Analog to host IBOC	1 Host analog to IBOC digital with no other impairments	<ol style="list-style-type: none"> The analog signal will be heavily modulated with processed stereo rock music. The host FM signal will include subcarrier group A. The DAR signal will be modulated with the primary impairment audio test material. 			
	2 Host analog to IBOC digital with multipath	<ol style="list-style-type: none"> The host IBOC analog modulation will be set for 110% with heavy processing, and the lab staff will listen for digital impairments. If impairments are heard the analog modulation will be reduced until no impairments are heard. If impairments are not heard in step #1, the FM modulation will be increased until impairments are heard or 150 % modulation is reached. The test results will be recorded on digital audio tape (DAT). 	EO&C in lab	M	Modulation percentage verses impairments
		<ol style="list-style-type: none"> The four multipath scenarios will be used for this test The analog modulation will be set for 110%. If impairments are heard the analog modulation will be reduced until no impairments are heard. The test results will be recorded on digital audio tape (DAT). 	EO&C in lab	M	Modulation percentage verses impairments

Appendix B. Recommended Lab Test Outline – AM-band

REVISION #2 October 8, 1998		IBOC LABORATORY TEST GUIDELINES-AM BAND			
Test Group	Test & Impairment	TEST PROCEDURE Note: The audio impairment test material will be used for the TOA test (see test K).	Type of Evaluation	Signal Level	Test Results Data to be Recorded
A Calibration	1 Power (each test day or as needed)	1. IBOC analog and digital power will be read separately. 2. The digital average and peak power will be measured for each system at least once.	Objective	NA	Power level
	2 Spectrum (each test day or as needed)	1. A spectrum analyzer plot of the system RF spectrum will be taken for each test. 2. The spectrum analyzer will be set up in accordance with FCC 73.44.	Objective	M	Laboratory log
	3 TOA (daily or as needed)	Gaussian noise will be added to the signal in 0.25 dB steps until TOA occurs (See test B). Test C-4, weak signal test, will also be conducted.	EO&C and Objective	M	TOA level
	4 Audio recording (as needed)	An audio recording will be made of all of the proponent audio channels (analog and digital).	EO&C	M & W	Digital audio recording for the test record
	5 Proof IBOC (weekly)	During the analog compatibility tests, a proof of performance test will be conducted weekly on the analog portion of the proponent IBOC systems. A high quality demodulator will be used for this test.	Objective	Varying	Record of frequency response, separation, and distortion for the test record
	6 Reference analog TX total proof	If a reference transmitter is used, a proof of performance test will be conducted on this transmitter, with and without subcarriers, prior to the compatibility tests. Both subcarrier groups will be calibrated.	Objective	NA	Test records
	7 Monitor calibration (weekly or as needed)	The analog modulation monitors will be calibrated monthly.	Objective	NA	Calibration results recorded in laboratory test record
	8 Test bed calibration (monthly)	All of the critical components in the test bed, transmission path simulators, attenuators, combiners, filters, generators, and measuring instruments, will be calibrated on a monthly schedule.	Objective	NA	Calibration record in test record

REVISION #2 October 8, 1998		IBOC LABORATORY TEST GUIDELINES-AM BAND			
Test Group	Test & Impairment	TEST PROCEDURE	Type of Evaluation	Signal Level dBm	Test Results Data to be Recorded
		Note: 1. Glockenspiel will be used for the digital audio impairment tests. 2. The detailed procedure for noise measurements will be supplied. See Appendix S of the Digital Audio Radio Laboratory Tests Report, August 11, 1995. 3. Clipped pink noise will be used for the host analog signal.			
B Impairment tests for characterization of DAR signal failure	1 Noise	1. Gaussian noise will be increased to TOA & POF (0.25 dB steps) and the levels logged. 2. From the TOA the noise will be increased in 0.5 dB steps until the noise is 0.5 dB beyond POF. For each 0.5 dB step a digitally recording will be made for expert subjective assessment.	EO&C	M	Noise level at TOA & POF

REVISION #2 October 8, 1998		IBOC LABORATORY TEST GUIDELINES-AM BAND			
	Test & Impairment	TEST PROCEDURE Notes:	Type of Evaluation	Signal Level	Test Results Data to be Recorded
C DAR with special impairment	1 Impulse noise	4. A generator capable of generating 100 nanosecond wide pulses with a rise and decay time of 3 to 4 nanoseconds will be used for the test. Pulse rates between 100 Hz to 1000 Hz will be used. All systems will be tested with a 120 Hz signal. 5. The pulse generator output will be mixed with the DAR signal. 6. The amplitude of the pulses will be increased until the laboratory specialist hears the TOA.	EO&C	M	Pulse amplitude in Volts P-P at TOA
	2 Weak signal	4. Starting with a medium signal level, the signal will be reduced to TOA & POF (0.25 dB steps). 5. A single audio impairment recording will be used for this test. 6. Characterize failure between TOA and POF in 0.5 dB steps. Note- weak signal test should be used to monitor the performance of the receiver hardware but should not be used to evaluate the proposed system.	EO&C	Varying	Signal level at TOA & POF

REVISION #2 October 8, 1998		IBOC LABORATORY TEST GUIDELINES-AM BAND			
Test Group	Test Number and Impairment	TEST PROCEDURE Note:	Type of Evaluation	Sig. Level	Test Results & Data to be Recorded
D DAR -> DAR	1 Co-channel	<ol style="list-style-type: none"> Two additional IBOC transmitters supplied by each proponent will generate the undesired DAR signals. The desired host analog signal will be modulated with clipped pink noise. Glockenspiel will be used for the digital audio impairment tests. 	EO&C in Lab	M	D/U & levels at TOA & POF Co-channel failure characteristics
	2 First adjacent	<ol style="list-style-type: none"> The undesired lower first adjacent composite IBOC signal will be increased in 0.5 dB steps until the TOE and POF are found. The test will be repeated with an upper first adjacent undesired signal. The test will be repeated with simultaneous upper and lower first adjacent undesired signals. 	EO&C in Lab	M	D/U & levels at TOA & POF
	3. Second adjacent	<ol style="list-style-type: none"> The undesired lower second adjacent composite IBOC signal will be increased in 0.5 dB steps until the TOE and POF are found. The test will be repeated with an upper second adjacent undesired signal. The test will be repeated with simultaneous upper and lower second adjacent undesired signals. 	EO&C in Lab	M	D/U & levels at TOA & POF
	4 Third adjacent	<ol style="list-style-type: none"> The first part of this test will be conducted with a minimum out-of-channel power. The undesired lower second adjacent DAR signal will be increased in 0.5 dB steps until the TOA and POF are observed. The test will be repeated with an upper third adjacent undesired signal. Simultaneous upper and lower second adjacent tests will be conducted. The tests will be repeated with the undesired signal's out-of-channel power increased in 5 dB steps until TOA and POF are detected in the desired IBOC audio. 	EO&C in Lab	M	D/U & levels at TOA & POF Third adjacent D/U with and without out-of-band components

REVISION #2 October 8, 1998		IBOC LABORATORY TEST GUIDELINES - AM BAND			
Test Group	Test & Impairment	TEST PROCEDURE	Type of Evaluation	Desired Signal Level	Test Results Data to be Recorded
		Notes: 1. These tests will compare the IBOC to analog with the analog to analog interference			
F DAR -> Analog (interference to an analog receiver with no other impairments)	<u>1 Co-channel objective</u>	1. The three AM receivers characterized in test L will be used for the AM band tests. 2. The desired AM transmitters will be set for 100% modulation. The desired transmitter will not be modulated. 3. The CCIR recommendation 412-4 weighting filter will be used for the program channel S/N measurements. 4. Increasing the undesired signal until the resulting audio signal/noise ratios are 25 and 40 dB (QPK), the D/U will be measured for the interference combinations: analog -> analog, and the DAR -> analog.	Objective	M	D/U at specified S/N for A -> A and D -> A
	<u>2 1st & 2nd adjacent</u>	1. The first and second adjacent channel procedures are the same as the co-channel procedures in F.1.1. The first and second adjacent channel measurement will be made with a single undesired signal operating above and below the desired signal frequency.	Objective	M	D/U at specified S/N for A -> A and D -> A
	<u>3 Co-channel</u>	1. The receivers used in step F.1.1 will be used for the subjective tests. 2. Classical music, rock music, and silence will be used for the desired channel analog audio. 3. The test will be conducted using the D/U that produced 25 dB and 40 dB audio S/N in test F-1. 4. The A to A reference and the test will be recorded on digital tape for demonstration or evaluation.	Subjective EO&C	M	Recordings for industry evaluation
	<u>5 1st & 2nd adjacent</u>	1. The subjective adjacent channel tests will use the procedures outlined in F.1, F.2, and F.3.	Subjective EO&C	M	Recordings for industry evaluation

REVISION #2 October 8, 1998		IBOC LABORATORY TESTS GUIDELINES - AM BAND			
Test Group	Test & Impairment	TEST PROCEDURE	Type of Evaluation	Desired Signal Level	Test Results Data to be Recorded
		Note: 1. The undesired analog signal will be modulated with processed rock stereo. 2. The host analog will be modulated with clipped pink noise. 3. Glockenspiel will be used for the digital audio impairment test.			
H Analog -> DAR (no other impairments)	<u>1 Co-channel</u>	1. The undesired co-channel analog standard AM signal will be increased in 0.5 dB steps until the TOA and POF are found.	EO&C in lab	M	D/U at TOA & POF
	<u>2 1st adjacent</u>	1. The undesired lower 1st adjacent analog standard AM signal will be increased in 0.5 dB steps until the TOA and POF are found. 2. This test will be repeated with an upper 1st adjacent undesired signal.	EO&C in lab	M	D/U at TOA & POF.
	<u>3 Simultaneous upper and lower 1st adjacent</u>	1. Simultaneous upper and lower 1st adjacent analog signals will be increased until the TOA and POF are heard (0.5 dB steps).	EO&C in lab	M	D/U at TOA & POF.
	<u>4 2nd adjacent</u>	Note - this test will be conducted on both upper and lower 2nd adjacent channels. 1. The undesired analog signal will be increased until the TOA and POF are observed (1.0 dB steps). 2. Simultaneous upper and lower second adjacent tests will be conducted.	EO&C in lab	M	D/U at TOA & POF

REVISION #2 October 8, 1998		IBOC LABORATORY TEST GUIDELINES – AM BAND			
Test Group	Test & Impairment	TEST PROCEDURE	Type of Evaluation	Desired Signal Level	Test Results Data to be Recorded
		Note: 1. The impairment audio will be Mozart track 67 on the SQAM disk. 2. The host analog channel will be modulated with clipped pink noise. 3. If clipped pink noise is heard during the test, the test will be repeated with the impairment audio simultaneously transmitted on the digital and host analog channels. 4. Each test will be repeated at least five times and the results averaged.			
J	<u>1 Simulated weak signal failure and acquisition</u>	1. Noise will be added to the signal in 0.25 dB steps until POF is found. The POF level will be recorded. 2. The DAR transmitter will be disconnected from the receiver for one (1) second to assure loss of lock. 3. The test will be repeated with the transmitter disconnected from the receiver for thirty (30) seconds to assure loss of lock. 4. Three tests will be conducted with the noise reduced in 2dB, 4dB, & 6 dB steps below POF for each test. 5. The signal will be reconnected to the DAR receiver, and acquisition time will be recorded for each noise level. Acquisition is audio with some impairments. The reproduced audio will be graded using the CCIR five-point impairment scale.	EO&C in lab	M	Acquisition time at each noise level and disconnect time.

REVISION #2 October 8, 1998		IBOC LABORATORY TEST GUIDELINES-AM BAND			
Test Group	Test Number and Impairment	Test Description	Type of Evaluation	Sig. Level	Test Results & Data to be Recorded
K DAR quality	1. Audio test segments Quality Impairment	1. The nine quality segments selected by the DAR Subcommittee will be used for the quality tests. 2. Glockenspiel will be used for the impairment tests.	NA	NA	NA
	2 Quality transmission test	1. The quality test materials selected in test K-1 will be transmitted through each DAR system and recorded digitally. 2. Each recorded segment will then be sent to a subjective assessment laboratory.	Subjective EO&C in Lab	M	Assessed using the ITU-R continuous 5-grade impairment scale (See Appendix U of the DAR Subcommittee Laboratory Tests Report)

Quality Audio Test Segments Selected by the DAR Subcommittee		
Description	Duration	Source
Dire Straits cut	30s	Warner Bros. CD 7599-25264-2 (track 6)
Pearl Jam cut	30s	Sony/Epic CD ZK53136 (track 3) with processing ¹
Sounds of water	30s	Roland Dimensional Space Processor Demo. CD
Glockenspiel	16s	EBU SQAM CD (track 35/Index 1)
Bass Clarinet arpeggio	30s	EBU SQAM CD (track 17/Index 1) with processing ¹
Music and rain	11s	AT&T mix
Susan Vega with glass	11s	AA&T mix
Muted trumpet	9s	Original DAT recording, University of Miami
Harpsichord arpeggio	12s	EBU SQAM CD (track 40/Index 1)

¹Processing chain used: Aphex Compellor Model 300 (set for leveling only)
Dolby Spectral Processor Model 740
Aphex Dominator II Model 720

REVISION #2		IBOC LABORATORY TEST GUIDELINES - AM BAND			October 8, 1998		
Test Group	Test & Impairment	TEST PROCEDURE			Type of Evaluation	Desired Signal Level	Test Results Data to be Recorded
		Notes: 1. The AM receiver compatibility performance tests are those outlined in the August 11, 1995 EIA DAR laboratory test report. 2. Analog program channel compatibility receiver noise tests will use quasi-peak detection and a CCIR weighting filter.					
L DAR -> Analog (IBOC -> host analog)	<u>1 IBOC to host analog</u>	1. Three representative AM receivers will be used for the compatibility tests. 2. The host AM transmitters will be set for 100% modulation with 1 kHz tone. The host analog transmitter will not be modulated. 3. For each of the compatibility receivers the audio S/N will be measured with and without the digital IBOC signal. The host AM to digital power ratio used in the performance test will be used for the compatibility tests. If the proponent elects to use multiple analog to digital ratios for the compatibility tests, the performance tests will also be conducted at these ratios.			Objective	S	AM audio S/N with and without
	<u>2 IBOC to host analog</u>	1. The same receivers used for test L.1 will be used for this test. 2. The desired audio signal will be moderately processed. 3. Classical music, rock music, silence, and spoken voice will be used for the audio. 4. The host and reference AM transmitters will be set for a 100% modulation with a 1 kHz tone. 5. For each analog receiver test, a digital audio recording will be made of the host IBOC analog audio signal with the digital signal turned on and off.			Subjective EO&C	S	Recordings for further subjective assessment or demonstration

REVISION #2		IBOC LABORATORY TEST GUIDELINES-AM BAND			October 8, 1998
Test Group	Test	TEST PROCEDURE Note:	Type of Evaluation	Desired Signal Level	Test Results & Data to be Recorded
M Analog -> DAR Analog to host IBOC	1 Host analog to IBOC digital with no other impairments	<ol style="list-style-type: none"> 1. The analog signal will be heavily modulated with processed rock music. 2. The DAR signal will be modulated with the primary impairment audio test material. 			
		<ol style="list-style-type: none"> 1. The host IBOC analog modulation will be set for 100% with heavy processing, and the lab staff will listen for digital impairments. 2. If impairments are heard the analog modulation will be reduced until no impairments are heard. 3. If impairments are not heard in step #1, the AM modulation will be increased until impairments are heard or 150 % modulation is reached. 4. The test results will be recorded on digital audio tape (DAT). 	EO&C in lab	M	Modulation percentage verses impairments

Appendix C. Analog Receiver Selection (Compatibility Testing)

The suggested test procedures described in Appendices A (FM) and B (AM) include compatibility tests designed to determine the effect that IBOC DAB has on existing analog main channel audio signals. The NRSC recommends that these tests be done using commercially-available analog receivers representative of a cross-section of receivers in use by consumers since, during the initial and transitional phases of IBOC DAB service introduction, these are the receivers which will primarily be in use, and therefore of primary interest with respect to analog compatibility.

In previous NRSC IBOC DAB tests, five FM and three AM radios were selected for use in compatibility testing, listed in Table C-1.² For FM, radios were selected from four categories: auto, portable, home Hi-Fi (high end), and home Hi-Fi (competitive). Two automobile radios were selected because of their large consumer populations and because of their dramatically different stereo-to-mono "blend" implementations. These auto radios also showed high adjacent channel rejection. The portable and personal portable use similar circuitry and have less adjacent channel rejection. The high end home Hi-Fi radios had good 2nd adjacent channel rejection, but exhibited first adjacent channel rejection characteristics similar to that found in the portable and home radios.

Table C-1. Analog Receivers Used in NRSC IBOC DAB Tests (1995)

CATEGORY	MAKE & MODEL	FM	AM
Auto	Delco model # 16192463	✓	✓
Auto	Ford model #F4XF-19B132-CB	✓	
Portable	Panasonic RX-FS430	✓	✓
Home Hi-Fi (high end)	Denon TU-380RD	✓	✓
Home Hi-Fi (competitive)	Pioneer SX-201	✓	

Table C-2 shows the result of the FM -> FM D/U tests that were conducted using the five radios. For the D/U measurements, the undesired signal RF level was adjusted for a 45 dB signal-to-noise ratio in the main channel audio of the desired signal. The audio noise measurements were made using quasi-peak detection, a 15 kHz low pass filter, and the CCIR filter. The desired signal level was -62 dBm. Antenna matching networks were used when needed. The portable and home receivers were tested in a shielded box that eliminated interference from other electronic devices in the laboratory. The two auto radios did not need additional shielding.

² See "Consumer Electronics Group, Electronic Industries Association, Digital Audio Radio Laboratory Tests - Transmission Quality Failure Characterization and Analog Compatibility, August 11, 1995" for additional information. Appendix H contains characterization data on the receivers in Table C-1.

Table C-2. FM Analog-to-analog D/U test results

- D/U values at which main channel audio signal achieves a 45 dB S/N ratio
- Test data from 1995 IBOC DAB laboratory tests (see footnote 2)

RECEIVER	CO-CHANNEL (D/U, dB)	1ST ADJ. CHANNEL (D/U, dB)	2ND ADJ. CHANNEL (D/U, dB)	113 kHz TEST (S/N, dB)
Delco	36.2	4.7	-45	No change
Ford	35.2	-6.1	-45.3	No change
Panasonic	40.9	27.3	-10.1	33.6
Denon	43.4	18.0	-28.9	34.0
Pioneer	44.2	26.6	-15.0	33.1

Additional information regarding receivers is included in Table C-3 and Figure C-1 which present information about radio listening by location (source: RADAR ® 56, Fall 1997, © Copyright Statistical Research, Inc.).

Table C-3. Radio Listening by Location

Weekdays (Monday-Friday, 24 hours)

Source: RADAR ® 56, Fall, 1997 (C) Copyright Statistical Research, Inc.

	PERCENT OF LISTENERS IN...		
	HOME	CAR	WORK OR OTHER
Persons 12+	37.1	42.3	20.6
Teens 12-17	43.3	36.5	20.2
Adults 18+	36.2	43.2	20.6
Men 18+	33.5	44	22.6
Women 18+	38.9	42.3	18.8

Figure C-1. Radio Listening by Location

Weekdays (Monday-Friday, 24 hours)

Source: RADAR © 56, Fall, 1997 (C) Copyright Statistical Research, Inc.

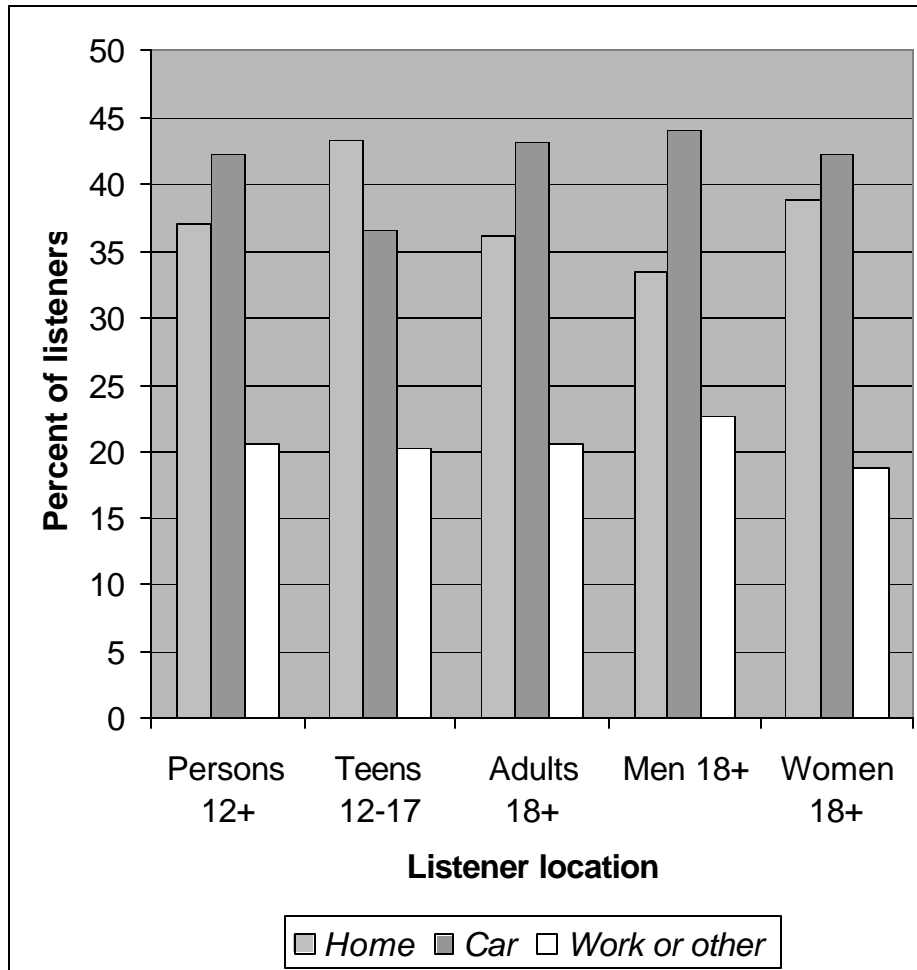

Appendix D. Test Matrix – Lab Test Guidelines, FM-band Portion

LAB TESTS, FM-BAND PORTION						INTERFERERS			COMMENTS
TEST	DESCRIPTION	AWGN	LINEAR	NON-LINEAR	FADING	Co-CHAN	1ST-ADJ	2ND-ADJ	
A	System calibration								
1)	Average and peak RF power measurements		✓						
2)	RF spectrum plot		✓						
3)	Digital audio subjective performance baseline	✓	✓						
4)	Baseline characterization of system digital performance	✓	✓						
5)	Analog proof-of-performance test results								
6)	Calibration record of equipment								
B	IBOC system performance with AWGN								
1)	Linear channel, no interferers	✓	✓						<ul style="list-style-type: none"> • Digital audio performance • Data transmission performance
2)	Linear channel, 1st-adjacent channel interference	✓	✓				✓		
3)	Multipath fading channel, no interferers	✓			✓				
4)	Multipath fading channel, 1st-adjacent channel interference	✓			✓		✓		
C	IBOC system performance with special impairments								
1)	Impulse noise		✓						<ul style="list-style-type: none"> • Digital audio performance • Data transmission performance
2)	Impulse noise, 1st-adjacent channel interference		✓				✓		
3)	Narrowband noise		✓						
4)	Narrowband noise, 1st-adjacent channel interference		✓				✓		
5)	Airplane flutter		✓						
6)	Airplane flutter, 1st-adjacent channel interference		✓				✓		
7)	Weak signal		✓						
8)	Weak signal, 1st-adjacent channel interference		✓				✓		
9)	Delay spread/doppler		✓						
10)	Delay spread/doppler, 1st-adjacent channel interference		✓				✓		
D	IBOC “digital-to-digital” compatibility performance								
1)	Co-channel interference		✓			✓			<ul style="list-style-type: none"> • Digital audio performance • Data transmission performance
2)	Single 1st-adjacent channel interference		✓				✓		
3)	Simultaneous upper and lower 1st-adjacent channel interference		✓				✓		
4)	Single 2nd-adjacent channel interference		✓					✓	
5)	Single 2nd-adjacent channel interference w/1st adj. channel interference		✓				✓	✓	

LAB TESTS, FM-BAND PORTION						INTERFERERS			COMMENTS
TEST	DESCRIPTION	AWGN	LINEAR	NON-LINEAR	FADING	Co-CHAN	1ST-ADJ	2ND-ADJ	
6)	Simultaneous upper and lower 2nd-adjacent channel interference		✓					✓	
7)	Simultaneous upper and lower 2nd-adjacent channel interference with non-linearity			✓				✓	
E	IBOC “digital-to-digital” compatibility performance in a multipath fading channel								
1)	Co-channel interference				✓	✓			<ul style="list-style-type: none"> Digital audio performance Data transmission performance
2)	Single 1st-adjacent channel interference				✓		✓		
3)	Simultaneous upper and lower 1st-adjacent channel interference				✓		✓		
4)	Single 2nd-adjacent channel interference				✓			✓	
5)	Single 2nd-adjacent channel interference w/1st adj. channel interference				✓		✓	✓	
6)	Simultaneous upper and lower 2nd-adjacent channel interference				✓			✓	
7)	Simultaneous upper and lower 2nd-adjacent channel interference with non-linearity			✓	✓			✓	
F	IBOC “digital-to-analog” compatibility performance								
1)	Co-channel interference		✓			✓			<ul style="list-style-type: none"> Analog main channel audio performance
2)	Single 1st-adjacent channel interference		✓				✓		
3)	Simultaneous upper and lower 1st-adjacent channel interference		✓				✓		
4)	Single 2nd-adjacent channel interference		✓					✓	
5)	Single 2nd-adjacent channel interference w/1st adj. channel interference		✓				✓	✓	
6)	Simultaneous upper and lower 2nd-adjacent channel interference		✓					✓	
G	IBOC “digital-to-analog” compatibility performance in a multipath fading channel								
1)	Co-channel interference				✓	✓			<ul style="list-style-type: none"> Analog main channel audio performance
2)	Single 1st-adjacent channel interference				✓		✓		
3)	Simultaneous upper and lower 1st-adjacent channel interference				✓		✓		
4)	Single 2nd-adjacent channel interference				✓			✓	
5)	Single 2nd-adjacent channel interference w/1st adj. channel interference				✓		✓	✓	

LAB TESTS, FM-BAND PORTION						INTERFERERS			COMMENTS
TEST	DESCRIPTION	AWGN	LINEAR	NON-LINEAR	FADING	Co-CHAN	1ST-ADJ	2ND-ADJ	
6)	Simultaneous upper and lower 2nd-adjacent channel interference				✓			✓	
H	IBOC “analog-to-digital” compatibility performance								
1)	Single 1st-adjacent channel interference		✓				✓		<ul style="list-style-type: none"> Digital audio performance Data transmission performance
2)	Simultaneous upper and lower 1st-adjacent channel interference		✓				✓		
3)	Single 2nd-adjacent channel interference		✓					✓	
I	IBOC “analog-to-digital” compatibility performance in a multipath fading channel								
1)	Single 1st-adjacent channel interference				✓		✓		<ul style="list-style-type: none"> Digital audio performance Data transmission performance
2)	Simultaneous upper and lower 1st-adjacent channel interference				✓		✓		
3)	Single 2nd-adjacent channel interference				✓			✓	
4)	Simultaneous upper and lower 2nd-adjacent channel interference				✓			✓	
J	IBOC acquisition/re-acquisition performance								
1)	Short interruption, linear channel		✓						<ul style="list-style-type: none"> Acquisition / re-acquisition performance
2)	Long interruption, linear channel		✓						
3)	Short interruption, linear channel, AWGN	✓	✓						
4)	Long interruption, linear channel, AWGN	✓	✓						
5)	Short interruption, linear channel, 1st-adj. channel interference		✓				✓		
6)	Long interruption, linear channel, 1st-adj. channel interference		✓				✓		
7)	Short interruption, fading channel				✓				
8)	Long interruption, fading channel				✓				
9)	Short interruption, AWGN, fading channel	✓			✓				
10)	Long interruption, AWGN, fading channel	✓			✓				
11)	Short interruption, fading channel, 1st-adj. channel interference				✓		✓		
12)	Long interruption, fading channel, 1st-adj. channel interference				✓		✓		
K	DAB quality								
1)	Subjective assessment report of unimpaired IBOC audio quality (linear channel) versus analog FM		✓						<ul style="list-style-type: none"> Suggested source and reference audio available from NRSC See Sect. 4.2
2)	“Long-form” DAT through IBOC system		✓						

LAB TESTS, FM-BAND PORTION						INTERFERERS			COMMENTS
TEST	DESCRIPTION	AWGN	LINEAR	NON-LINEAR	FADING	Co-CHAN	1ST-ADJ	2ND-ADJ	
L	IBOC “digital-to-host analog” compatibility performance								
1)	Host analog main channel audio performance versus presence or absence of IBOC digital signal energy		✓						<ul style="list-style-type: none"> • Host analog main channel audio performance • Host subcarrier performance
2)	Host analog main channel audio performance versus presence or absence of IBOC digital signal energy				✓				
3)	Host subcarrier audio and/or data performance versus presence or absence of IBOC digital signal energy		✓						
4)	Host subcarrier audio and/or data performance versus presence or absence of IBOC digital signal energy				✓				
M	IBOC “host analog-to-digital” compatibility performance								
1)	Digital audio, data transmission performance versus percent modulation of analog host signal		✓						<ul style="list-style-type: none"> • Digital audio performance • Data transmission performance
2)	Digital audio, data transmission performance versus percent modulation of analog host signal				✓				

Appendix E. Test Matrix – Lab Test Guidelines, AM-band Portion

LAB TESTS, AM-BAND PORTION						INTERFERERS				COMMENTS
TEST	DESCRIPTION	AWGN	LINEAR			Co-CHAN	1ST-ADJ	2ND-ADJ	3RD-ADJ	
A	System calibration									
1)	Average and peak RF power measurements		✓							
2)	RF spectrum plot		✓							
3)	Digital audio subjective performance baseline	✓	✓							
4)	Baseline characterization of system digital performance	✓	✓							
5)	Analog proof-of-performance test results									
6)	Calibration record of equipment									
B	IBOC system performance with AWGN									
1)	Linear channel, no interferers	✓	✓							<ul style="list-style-type: none"> Digital audio performance Data transmission performance
C	IBOC system performance with special impairments									
1)	Impulse noise		✓							<ul style="list-style-type: none"> Digital audio performance Data transmission performance
2)	Weak signal		✓							
D	IBOC “digital-to-digital” compatibility performance									
1)	Co-channel interference		✓			✓				<ul style="list-style-type: none"> Digital audio performance Data transmission performance
2)	Single 1st-adjacent channel interference		✓				✓			
3)	Simultaneous upper and lower 1st-adjacent channel interference		✓				✓			
4)	Single 2nd-adjacent channel interference		✓					✓		
5)	Simultaneous upper and lower 2nd-adjacent channel interference		✓					✓		
6)	Single 3rd-adjacent channel interference								✓	
F	IBOC “digital-to-analog” compatibility performance									
1)	Co-channel interference		✓			✓				<ul style="list-style-type: none"> Analog main channel audio performance
2)	Single 1st-adjacent channel interference		✓				✓			
3)	Single 2nd-adjacent channel interference		✓					✓		

LAB TESTS, AM-BAND PORTION						INTERFERERS				COMMENTS
TEST	DESCRIPTION	AWGN	LINEAR			Co-CHAN	1ST-ADJ	2ND-ADJ	3RD-ADJ	
H	IBOC “analog-to-digital” compatibility performance									
1)	Co-channel interference					✓				<ul style="list-style-type: none"> Digital audio performance Data transmission performance
2)	Single 1st-adjacent channel interference		✓				✓			
3)	Simultaneous upper and lower 1st-adjacent channel interference		✓				✓			
4)	Single 2nd-adjacent channel interference									
3)	Simultaneous upper and lower 2nd-adjacent channel interference		✓					✓		
J	IBOC acquisition/re-acquisition performance									
1)	Short interruption, linear channel		✓							<ul style="list-style-type: none"> Acquisition / re-acquisition performance
2)	Long interruption, linear channel		✓							
3)	Short interruption, linear channel, AWGN	✓	✓							
4)	Long interruption, linear channel, AWGN	✓	✓							
K	DAB quality									
1)	Subjective assessment report of unimpaired IBOC audio quality (linear channel) versus analog AM (and optionally, analog FM)		✓							<ul style="list-style-type: none"> Suggested source and reference audio available from NRSC
2)	“Long form” DAT through IBOC system		✓							<ul style="list-style-type: none"> See Sect. 4.2
L	IBOC “digital-to-host analog” compatibility performance									
1)	Host analog main channel audio performance versus presence or absence of IBOC digital signal energy		✓							<ul style="list-style-type: none"> Host analog main channel audio performance
M	IBOC “host analog-to-digital” compatibility performance									
1)	Digital audio, data transmission performance versus percent modulation of analog host signal		✓							<ul style="list-style-type: none"> Digital audio performance Data transmission performance

Appendix F. DAB Subcommittee Goals & Objectives



2500 Wilson Boulevard
Arlington, VA 22201-3834
(703) 907-7500
FAX (703) 907-7501

NATIONAL RADIO SYSTEMS COMMITTEE



1771 N Street, NW
Washington, DC 20036-2891
(202) 429-5339
FAX (202) 775-4981

5/14/98

DAB Subcommittee

Goals & Objectives

(as adopted by the Subcommittee on May 14, 1998)

Objectives

- (a) To study IBOC DAB systems and determine if they provide broadcasters and users with:
- A digital signal with significantly greater quality and durability than available from the AM and FM analog systems that presently exist in the United States;
 - A digital service area that is at least equivalent to the host station's analog service area while simultaneously providing suitable protection in co-channel and adjacent channel situations;
 - A smooth transition from analog to digital services.
- (b) To provide broadcasters and receiver manufacturers with the information they need to make an informed decision on the future of digital audio broadcasting in the United States, and if appropriate to foster its implementation.

Goals

To meet its objectives, the Subcommittee will work towards achieving the following goals:

- (a) To develop a technical record and, where applicable, draw conclusions that will be useful to the NRSC in the evaluation of IBOC systems;
- (b) To provide a direct comparison between IBOC DAB and existing analog broadcasting systems, and between an IBOC signal and its host analog signal, over a wide variation of terrain and under adverse propagation conditions that could be expected to be found throughout the United States;
- (c) To fully assess the impact of the IBOC DAB signal upon the existing analog broadcast signals with which they must co-exist;
- (d) To develop a testing process and measurement criteria that will produce conclusive, believable and acceptable results, and be of a streamlined nature so as not to impede rapid development of this new technology;
- (e) To work closely with IBOC system proponents in the development of their laboratory and field test plans, which will be used to provide the basis for the comparisons mentioned in Goals (a) and (b);
- (f) To indirectly participate in the test process, by assisting in selection of (one or more) independent testing agencies, or by closely observing proponent-conducted tests, to insure that the testing as defined under Goal (e) is executed in a thorough, fair and impartial manner.

Appendix G. IBOC Status Report (6/98)

"In-band/on-channel (IBOC) DAB – a Status Report," published in the proceedings of the 1998 Radio Montreux Conference.

**Appendix C –
IBOC DAB System Test Guidelines – Part II –
Field Tests**



2500 Wilson Boulevard
Arlington, VA 22201-3834
(703) 907-7500
FAX (703) 907-7501

NATIONAL RADIO SYSTEMS COMMITTEE



1771 N Street, NW
Washington, DC 20036-2891
(202) 429-5346
FAX (202) 775-4981

(adopted 4/17/99)

DAB SUBCOMMITTEE IBOC DAB System Test Guidelines (Part II – Field Tests)

Addendum #1 Out-of-channel Power Measurement Procedure

This addendum describes a recommended procedure for characterizing the out-of-channel signal power at the output of an FM transmitter due to the addition of an IBOC digital signal to a normal analog FM transmission.

The procedure described herein augments information contained in Section 5.1.1 (Test A – System Calibration) of the field test guideline, specifically, Desired Result #5 (Analog transmission system test results). Proponents intending to submit IBOC system performance data to the NRSC for evaluation are asked to include the data being requested by this addendum in addition to desired results already spelled out in the test guidelines documents.

Assumed in this procedure is that the FM IBOC signal consists of upper and lower (with respect to the analog host) digital sidebands (refer to Figure 1, and also to Appendix G of Part I of the IBOC DAB System Test Guidelines for additional information). For the purposes of this procedure, “out-of-channel” refers to that portion of the RF spectrum immediately adjacent to the outer edges of the upper and lower digital sidebands, as shown in Figure 1. Note that the out-of-channel region, as defined, may vary from system to system, and that the out-of-channel region also may include frequencies which fall within the FCC mask for the system under test.

The suggested procedure is divided into two parts. The first part is designed to characterize the out-of-channel energy immediately adjacent to the digital sidebands, which would fall within a 2nd adjacent signal’s digital sidebands were a 2nd adjacent signal present.

In the second part, the out-of-channel energy due to third-order intermodulation products, falling in the spectral region from 200 kHz to 600 kHz above and below the signal under test center frequency, is measured. Note that this region represents the spectral extent of a 2nd adjacent channel IBOC signal.

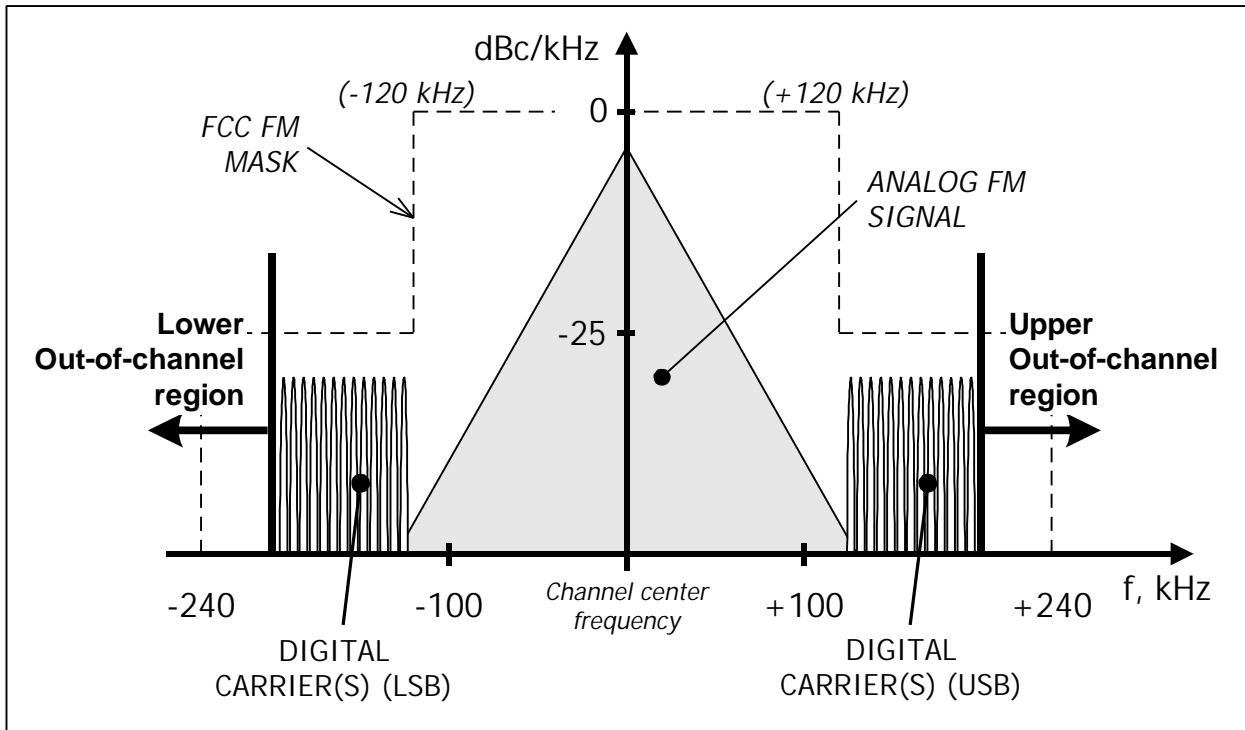

Figure 1. Illustration of “out-of-channel” region for an FM IBOC system, as defined for the purpose of this addendum.

(DRAFT #2)
OUT-OF-CHANNEL POWER MEASUREMENT PROCEDURE
March 22, 1999

Objectives:

1. Measure IBOC digital signal power in IBOC adjacent channels.
2. Measure third order products between 390 kHz to 600 kHz above and below host FM center frequency.

Digital power in IBOC adjacent channel

1. Measurements should be made at the output of the combiner (antenna input port) into a dummy load with the transmitter operating in its normal IBOC mode. Test will be repeated into the transmitting antenna.
2. First part of test will be conducted with analog transmitter off.
3. Measure total digital power with an average power meter (both digital sidebands on).
4. Measure individual 70 kHz sideband average power with a spectrum analyzer using the adjacent-channel power feature (see HP8591E series). The individual sideband should be 3 dB below the power meter total average power reading.
5. To measure the power in the adjacent IBOC channel, set the spectrum analyzer adjacent-channel power frequency marker at the frequency where the second adjacent channel starts (same sideband width). Power is measured in dB below the host IBOC individual sideband.
6. Repeat measurements with analog transmitter on.

Third order products

1. Measurements should be made at the output of the combiner (antenna input port) into a dummy load with the transmitter operating in its normal IBOC mode. Test will be repeated into the transmitting antenna.
2. First part of test will be conducted with analog transmitter off.
3. Measure out-of-channel power from 200 - 600 kHz above and below the host FM center frequency by averaging the power spectral density of the signal in each 1 kHz bandwidth over a 15-second segment of time.
4. Repeat measurements with analog transmitter on and digital transmitter off.
5. Final step is to repeat the measurements with analog and digital transmitters on.



2500 Wilson Boulevard
Arlington, VA 22201-3834
(703) 907-7500
FAX (703) 907-7501

NATIONAL RADIO SYSTEMS COMMITTEE



1771 N Street, NW
Washington, DC 20036-2891
(202) 429-5346
FAX (202) 775-4981

(adopted 4/17/99)

DAB SUBCOMMITTEE IBOC DAB System Test Guidelines (Part II – Field Tests)

Addendum #2 Qualitative Characteristics of Field Test Routes

This addendum provides additional information regarding desirable qualitative aspects (from a system testing standpoint) of mobile routes used for field testing IBOC systems. Proponents intending to submit IBOC system performance data to the NRSC for evaluation are asked to consider the information in this addendum as they plan their test routes for data collection.

As discussed in the Field Test Guidelines, the NRSC expects proponents to collect a significant part, if not the majority, of the field test data from a mobile platform, given that the mobile environment offers some of the most severe and demanding conditions encountered, and because this is the environment where a large percentage of radio listening occurs. Some of the key qualitative characteristics the selected field test routes should have are as follows:

- Line-of-sight condition (to antenna)
- Terrain shielded condition
- Significant shielding by buildings
- Vertical shielding (tunnels/wires)
- Major over-water propagation path
- Travel along waterfront areas
- Significant foliage along part of propagation path
- Rural areas
- Primarily highway travel
- Residential areas covered/directly adjacent
- “Fringe” FM reception areas

It is recommended that proponents select test routes such that at the conclusion of their test program, all of these characteristics are evident in the collected data.



2500 Wilson Boulevard
Arlington, VA 22201-3834
(703) 907-7500
FAX (703) 907-7501

NATIONAL RADIO SYSTEMS COMMITTEE



1771 N Street, NW
Washington, DC 20036-2891
(202) 429-5346
FAX (202) 775-4981

(adopted 4/17/99)

DAB SUBCOMMITTEE IBOC DAB System Test Guidelines (Part II – Field Tests)

Addendum #3 Additional Information on Data Formatting

This addendum provides additional information regarding data formatting of IBOC system data submission. Proponents intending to submit IBOC system performance data to the NRSC for evaluation are asked to consider the information in this addendum as they prepare their submission.

Recorded audio – the NRSC expects that proponents will use a variety of recording media for data collection including but not limited to digital audio tape (DAT) and digital recording directly onto hard disks and/or compact discs (CDs).

The preferred format for audio recording submission to the NRSC is linear CD audio with a sampling rate of 44.1 kHz. Use of the CD format minimizes or eliminates the possibility of alteration of the submitted material and allows the evaluators to make use of widely available, high-quality playback equipment. Alternatively, a proponent may elect to submit audio in DAT format.

The use of digital audio compression (for the purpose of bit rate reduction) at any point in the audio collection process would be inadvisable, and the NRSC assumes that the only digital audio compression existing in any submitted recordings is that of the IBOC perceptual audio coding system alone.

Computer-based data – in the event that a proponent submits data in computer form, it should be in “machine-readable” format, using tabs, commas, or quotation marks to delimit the different fields of data. Spaces may also be used as a delimiter in combination with the delimiters identified above or, when on ambiguity would result, alone. Data may also be presented in any format that can be imported into a Microsoft Excel spreadsheet.



2500 Wilson Boulevard
Arlington, VA 22201-3834
(703) 907-7500
FAX (703) 907-7501

NATIONAL RADIO SYSTEMS COMMITTEE



1771 N Street, NW
Washington, DC 20036-2891
(202) 429-5346
FAX (202) 775-4981

(draft 9/27/99)

DAB SUBCOMMITTEE IBOC DAB System Test Guidelines (Part II – Field Tests)

Addendum #4 Inclusion of "Mode" signal in data report

This addendum provides additional information regarding specific data being requested for inclusion in an IBOC system data submission. Proponents intending to submit IBOC system performance data to the NRSC for evaluation are asked to consider the information in this addendum as they prepare their submission.

At the August 13, 1999 meeting of the Evaluation Working Group, a need was identified for a "mode" signal to be included as part of a proponents submission of test results. This group has determined that such information will be instrumental in characterizing the operation of IBOC systems which utilize different modes based on transmission conditions.

This mode signal would indicate the particular mode of an IBOC audio signal versus time (for example, as part of a field test run) or versus operating point (as in a laboratory adjacent channel test), and would be analogous to the stereo pilot indicator provided by an analog FM stereo receiver. This information would apply to all tests, i.e., the IBOC audio signal mode is of interest for all modes of operation and under any test conditions.

Based on the technical disclosures made by the current IBOC proponents, it is expected that for USA Digital Radio, the mode indicator would indicate when the IBOC audio had "blended to analog," and for Lucent Digital Radio, the number of streams actually being used in the multi-stream audio processing at the receiver (e.g., from 1 to 4 for their FM system). For Digital Radio Express, it is not presently known if a mode signal would be appropriate, however, DRE is requested to make this evaluation based on the needs of the NRSC as expressed herein and on the particulars of their system's design.

Proponents are also encouraged to submit any auxiliary information which would help to characterize the audio quality represented by a particular mode (as indicated by the mode signal), for example, by conducting subjective evaluations on data for which the mode signal information has been collected.



2500 Wilson Boulevard
Arlington, VA 22201-3834
(703) 907-7500
FAX (703) 907-7501

**NATIONAL
RADIO
SYSTEMS
COMMITTEE**



1771 N Street, NW
Washington, DC 20036-2891
(202) 429-5346
FAX (202) 775-4981

D A B S u b c o m m i t t e e

**In-band/On-channel (IBOC)
Digital Audio Broadcasting (DAB)
System Test Guidelines**

Part II – Field Tests

(as adopted by the Subcommittee on March 4, 1999)

Table of Contents

1	INTRODUCTION	3
2	PROPONENT SUBMISSIONS TO THE NRSC	4
3	DEFINITIONS	6
4	FIELD TEST AUDIO EVALUATION	8
4.1	IMPAIRMENT OBSERVATIONS.....	9
4.2	INFORMAL SUBJECTIVE EVALUATION.....	9
5	FIELD TEST GUIDELINES	12
5.1	FM-BAND PORTION	13
5.1.1	<i>Test A - System Calibration</i>	13
5.1.2	<i>Test B – Strong signal with low interference</i>	14
5.1.3	<i>Test C – Single interferer</i>	15
5.1.4	<i>Test D – Two interferers</i>	16
5.2	AM-BAND PORTION.....	17
5.2.1	<i>Test A - System Calibration</i>	17
5.2.2	<i>Test B – System performance within protected contour and low interference (day)</i>	18
5.2.3	<i>Test C - System performance within protected contour (day and night)</i>	19

List of Appendices

APPENDIX A. RECOMMENDED FIELD TEST OUTLINE – FM-BAND.....	20
APPENDIX B. RECOMMENDED FIELD TEST OUTLINE – AM-BAND	26
APPENDIX C. ANALOG RECEIVER SELECTION (FIELD TESTING).....	31
APPENDIX D. TEST MATRIX – FIELD TEST GUIDELINES, FM-BAND PORTION.....	34
APPENDIX E. TEST MATRIX – FIELD TEST GUIDELINES, AM-BAND PORTION.....	36
APPENDIX F. SUGGESTED FIELD TEST ASSESSMENT DATA LOGGING CONVENTIONS AND REPORTING FORM.....	38
APPENDIX G. DAB SUBCOMMITTEE GOALS & OBJECTIVES	41

List of Tables

TABLE 5-1. FIELD TEST GUIDELINES SUMMARY – IBOC SYSTEM, FM-BAND PORTION.....	12
TABLE 5-2. FIELD TEST GUIDELINES SUMMARY – IBOC SYSTEM, AM-BAND PORTION	12

List of Figures

FIGURE 1. SUGGESTED AUDIO PROCESSOR CONFIGURATION TO FACILITATE INFORMAL SUBJECTIVE EVALUATION OF FIELD TEST AUDIO.....	11
---	----

(ADDITIONAL TABLES AND FIGURES MAY BE FOUND IN THE APPENDICES)

1 Introduction

These test guidelines, developed by the Test Guideline Working Group (TGWG), Mr. Andy Laird, Chairman, of the DAB Subcommittee of the National Radio Systems Committee (NRSC), are the result of a cooperative effort between broadcasters, receiver manufacturers, and IBOC DAB system developers. Fundamentally, they describe the field test results needed by the broadcasting and receiver manufacturing industries in order to assess the viability and desirability of proposed IBOC systems.

Part I of these test guidelines, covering laboratory tests, was formally adopted by the DAB Subcommittee at its December 3, 1998 meeting. This document (Part II), combined with Part I, fully defines the NRSC's requirements for IBOC system test results needed for its evaluative process to commence. Note that the release of these test guidelines documents in two parts has been done solely to help expedite the test process and *is not* meant to imply that submissions to the NRSC should be in two parts, as well. This guideline release schedule was selected to follow the natural progression of system development, which is from the laboratory into the field, and allows the NRSC to provide IBOC proponents with its test guidelines in the most timely fashion possible.

As fully explained in Section 2 of Part I (included in this document for completeness), proponent submissions are expected to be complete and include any and all laboratory and/or field test data which the proponent wishes the NRSC to consider. Additional information contained in Part I, of an introductory and general nature, is not repeated here and should be carefully reviewed by proponents prior to data submission to the NRSC.

Proponent submissions received by the NRSC which follow these guidelines can be expected to undergo a thorough review and analysis by the DAB Subcommittee, as it strives to determine whether or not submitted systems represent a significant improvement over the existing AM and FM analog radio transmission methods in use today, and otherwise appear to be viable IBOC DAB systems (see Appendix G for a statement of the DAB Subcommittee's Goals and Objectives). This evaluation process will be discussed in detail in a separate NRSC report entitled "IBOC DAB System Test Guidelines – The NRSC Evaluation Process," currently under development and expected to be released shortly.

2 Proponent Submissions to the NRSC

(This section is taken in its entirety from Part I of the NRSC's IBOC DAB System Test guidelines, and is included here for sake of completeness.)

Proponents need to submit the following information to the NRSC in order for the DAB Subcommittee to be able to effectively evaluate their system:

- a) Detailed system description including:
 - i) High level description and theory of operation
 - ii) Transmission equipment description / requirements
 - iii) Receiver equipment description / requirements
 - iv) Compliance with (or changes necessary to) FCC rules
- b) Description of test procedures followed – note that Appendices A and B include suggested laboratory test procedures which are based on the experience gained by the NRSC in its prior DAB test efforts (Part II of these guidelines will include similar information for field testing). It is especially important that proponents electing to use test procedures which differ significantly from the suggested procedures provide detailed information on the procedures which were followed.
- c) Statement of oversight – proponents are expected to retain an independent, third-party observer (preferably an expert in broadcast and/or digital communications engineering) who will follow and/or review the system testing (done by the proponent) closely and personally certify the submitted results as an accurate record of the actual measured system performance. Alternatively, proponents may elect to make use of an independent system testing contractor for implementation of the test program.

This is a vital part of the proponent submission, which will allow the NRSC to evaluate with confidence the proponent-submitted data as an accurate depiction of performance.

- d) Test results obtained using procedures described in b) above. Proponents are strongly encouraged to follow the labeling and other conventions regarding test results established in this test guidelines document.

In accordance with DAB Subcommittee policy, data submissions (system descriptions, test procedures, test results, etc.) made by IBOC proponents to the NRSC for purposes of evaluation must be:

- on complete systems, that is, systems which provide for IBOC DAB in both the AM and FM bands. A submission made on a system which only operates in one of these bands will only be considered if, along with that submission, the proponent states its intention to *only* support IBOC operation in that single band, and furthermore, why they have elected not to develop a system which supports operation in both bands. Note that in such instances, the NRSC may elect not to evaluate the submission, in particular if submissions have been made by other proponents which support operation in both bands.
- made at the conclusion of the system development effort, that is, must represent the performance of a completed system. Test results taken on partially completed systems

and/or preliminary results from (comprehensive) test programs will not be accepted, nor will multiple submissions (*e.g.*, revised submissions) for a system already submitted.

Again, proponents are strongly encouraged to follow the NRSC IBOC System Test Guidelines (*i.e.* this document and Part II, Field Tests, when available) when preparing a submission, and indicate as part of their submission which desired test results (as stated in the Guidelines) are included. Appendices C and D (system test matrices) of this document were developed to serve as “checklists” which proponents can include with their submission, providing a straightforward way to indicate which requested test results have been obtained (similar checklists will be included in Part II).

3 Definitions

Acquisition/re-acquisition performance – the aspect of IBOC system performance characterized by the length of time needed to acquire (initially) or re-acquire (after an interruption in service) an IBOC transmission.

Analog main channel audio performance – performance (objective and/or subjective) of the analog main channel audio portion of a sound broadcasting transmission, either AM or FM, IBOC or (traditional) analog.

Bit Error Rate (BER) – a measure of digital system performance, simply, the ratio of the number of bits received in error, to the total number of bits received.

Co-channel signal – the RF signal co-located with, i.e. having the same center frequency as, a desired sound broadcasting signal. Note that the co-channel signal, for the purposes of IBOC DAB system evaluation, can be either a standard analog signal or an IBOC DAB signal.

Data transmission performance – performance of that portion of the IBOC system set aside for data transmission specifically (i.e. not used to carry the digital audio bit stream), typically characterized by BER, FER, etc. As used in Section 5 and unless otherwise indicated, this term refers to the performance of the “auxiliary” or “ancillary” data transmissions (terms often used by IBOC proponents and others to describe this portion of the system).

Desired signal – refers to a sound broadcasting signal (AM or FM, IBOC or non-IBOC) under test.

Digital audio performance – performance (objective and/or subjective) of the digital audio portion of the IBOC system.

First adjacent signal – the RF signal located either ± 200 kHz (for FM) or ± 10 kHz (for AM) away from the center frequency of a desired sound broadcasting signal. Note that the first adjacent signal, for the purposes of IBOC DAB system evaluation, can be either a standard analog signal or an IBOC DAB signal.

Frame – a particular segmentation of bits (or bytes) occurring within a system by virtue of some aspect of the system's design. For example, audio coding schemes such as PAC and MPEG-2 AAC format the coded digital audio data streams into frames of a specific definition, delineated by specific patterns of bits (e.g., headers, etc.) and with a predefined structure.

Frame Error Rate (FER) – a measure of digital system performance, simply, the ratio of the number of frames received in error, to the total number of frames received.

Host analog main channel audio performance – performance (objective and/or subjective) of the analog main channel audio portion of an IBOC system, considered to be the “host” to the IBOC digital carriers.

Host signal – the analog (AM or FM) sound broadcast signal which exists in the same channel as the digital portion of an IBOC DAB signal.

Host subcarrier performance – performance (objective and/or subjective) of the subcarrier (i.e.

SCA) signals associated with the analog carrier portion of an IBOC system (typically applies to FM systems only).

In-band/on-channel (IBOC) DAB – a method of digital audio broadcasting in which a digital audio signal is combined, in a mutually compatible fashion, with an existing analog audio signal (either AM or FM), in such a manner as to be consistent with the FCC rules (present or future) for AM and FM sound broadcasting.

Nighttime service – (for AM stations) defined as broadcast service occurring between 2 hours after sunset and 2 hours before sunrise.

Second adjacent signal – the RF signal located either ± 400 kHz (for FM) or ± 20 kHz (for AM) away from the center frequency of a desired sound broadcasting signal. Note that the second adjacent signal, for the purposes of IBOC DAB system evaluation, can be either a standard analog signal or an IBOC DAB signal.

Third adjacent signal – the RF signal located either ± 600 kHz (for FM) or ± 30 kHz (for AM) away from the center frequency of a desired sound broadcasting signal. Note that the third adjacent signal, for the purposes of IBOC DAB system evaluation, can be either a standard analog signal or an IBOC DAB signal.

Total Average Digital Power – the average RF signal power contained in the entire digital carrier portion of the IBOC signal (all digital carriers and sidebands taken together).

Undesired signal – refers to a sound broadcasting signal (AM or FM, IBOC or non-IBOC), present along with a desired signal, as either a co-channel or adjacent channel signal.

4 Field Test Audio Evaluation

Evaluation of audio signals obtained in a field testing environment presents numerous challenges over similar evaluations done on laboratory data. This stems from the fact that there are a host of uncontrollable variables and unknown elements in a field test, from the state of the equipment in the broadcasting facility, to the material being broadcast, to the intricacies of the transmission environment itself.

To understand the role that “field test audio” plays in the evaluation of an IBOC system, one must remember that *precise* characterization of the unimpaired audio quality of these systems is addressed during laboratory testing of such systems, as discussed in of Part I of these guidelines (refer to Section 4, “Subjective Evaluation Guidelines”). It is not expected (nor would it even be possible) that data collected in the field could undergo the type of subjective analysis discussed in Part I and generate meaningful results.

Conversely, there are aspects of the performance of an IBOC system which cannot be established by laboratory experimentation and must be determined by field testing, most notably impairment observations and “informal” (field test) subjective evaluation, and it is these aspects which are discussed in the subsections below. These aspects are mentioned here together, but of the two, the NRSC considers the impairment observations to be far and away the more significant. In fact, unless the audio signals are handled properly (as discussed in greater detail below), the results of any field test subjective evaluation, informal or otherwise, may yield little or no information pertinent to the evaluation of the IBOC system under test.

During field test data collection, it is expected that proponents will simultaneously record, preferably on digital media (digital audio tape, computer hard disk, etc):

- IBOC digital audio (system under test);
- Analog host audio, using at least two different analog receivers (as discussed in Appendix C).

These recordings should be done so that it will be possible, after the fact, to time-align individual recordings (for example, the IBOC digital audio and one of the analog host audio recordings) and analyze their performance under similar reception conditions. Proponents are also encouraged to collect other supplemental data, such as video recordings of the reception environment, received RF signal strength, RF adjacent channel environment, etc., in synchronism with the collected audio, to allow for a full interpretation of the results.¹

The NRSC expects proponents to collect a significant part, if not the majority, of the field test data from a mobile platform, given that the mobile environment offers some of the most severe and demanding conditions encountered, and because this is the environment where a large percentage of radio listening occurs.² Consequently, the audio and data recording equipment suggested in the preceding two paragraphs is expected to reside on a mobile platform.

In addition, proponents may also want to consider establishing a fixed data collection

¹ For an example of a prior DAB field test data collection effort, refer to “Report of the Field Test Task Group; Field Test Data Presentation,” Working Group B “Testing” of the CEMA-DAR Subcommittee, December, 1996.

² See Appendix C of Part I of these guidelines for statistical information on listening habits.

site, located in the vicinity of where the mobile observations will take place, in a location with favorable reception conditions. Data from this fixed-site might prove useful during analysis, for resolving questions about the data collected at the same time on the mobile platform, for example, to try and determine if a particular impaired segment were a function of mobile reception or due to a transmission problem. This fixed-site data would be most useful if it were obtained using the same types of receivers (analog, in particular) as used on the mobile platform.

4.1 Impairment observations

The principle benefit to be obtained from analysis of IBOC systems in field tests, given that formal subjective analysis of unimpaired audio quality is best performed in a laboratory, is to establish how channel impairments manifest themselves in received IBOC (and host analog) audio. Typical channel impairments include multipath interference, signal blockage, adjacent and co-channel interference (analog or IBOC), etc., and are likely to be most pronounced in a mobile reception environment.

Impairment observations, in this context, involve listening carefully to an audio signal for undesirable sounds (not part of the original audio program), or no sound at all (i.e. a muted condition) or artifacts (such as can occur in perceptually coded audio, or in the case of analog, such phenomena as blend to mono), caused by problems with reception of the audio signal's radio source. These observations are subjective in nature since these undesirable sounds are identified by a human listener and not measured with an objective measuring device.

One possible way to conduct such observations is exemplified in the data record of the EIA/DAR Subcommittee's 1996 field test of DAB systems, referred to in the previous section. During those tests, two expert listeners in a mobile test vehicle continuously monitored the received digital audio signals and, using a computer keypad, indicated which of three conditions existed at any given time: unimpaired, impaired, or muted audio. This determination was logged along with the rest of the data being collected during the field test, and at the conclusion of the test, it was possible to compare visually (and otherwise) the occurrence of audio impairments with other parameters such as vehicle speed, received RF signal level, etc. An example of such a graphical comparison is given in Appendix F. It was also possible to develop statistics on the audio impairments including percent of the time (for a given test run) that the audio was unimpaired, impaired, or muted.

Although the impairment observations were made in real time during the EIA/DAR tests, this need not be the case. Equally valid evaluations could also be obtained after the fact, using digital audio recordings of the received audio signals. Ideally, proponents interested in submitting data to the NRSC would perform these observations on the host analog audio, as well, since the NRSC's primary objective is to be able to determine how these two services compare. Observers should have common and consistent training to conduct evaluations.

4.2 Informal subjective evaluation

Characterization of audio impairments experienced in the field, as just discussed, is vital to the overall assessment of the IBOC system performance. This information, combined with the unimpaired subjective evaluation results obtained in the laboratory, provides the basis for audio quality evaluation of an IBOC system. However, the field test audio impairment results

provide a “real-world” quality which broadcasters and receiver manufacturers can also use to complete assessments.

Under certain conditions (discussed below) it becomes possible to utilize the same audio information used for the impairment analysis in an “informal” field test evaluation, with the goal of establishing an opinion as to the “quality” of the IBOC digital audio, in particular, compared to the “quality” of the analog audio which was collected at the same time (and under the same conditions). If this is to be done, then as many unrelated variables as possible must be eliminated from the audio being evaluated.

It is important to note that collectively, field test audio will have been passed through various radio stations in various markets, and that there are many things taking place within each of these stations affecting the quality of the received audio (and outside of the control of the IBOC system evaluation process) in addition to the transmission system itself. If an informal evaluation of field test audio quality is to be done, the field testing methodology must be structured to minimize these non-transmission system effects, so that the resulting evaluation will be able to highlight differences in transmission system performance.

Some of the variables that can affect the field test audio include:

- The microphones, microphone processing, and pre-amps used;
- The quality of the mixing desk and operator;
- The broadcast audio chain processing;
- Additional electronic elements in the broadcast chain such as distribution amplifiers, routers, STL's;
- Transmitter type and tuning, antenna system and bandwidth, etc.

While as a practical matter many of these variables cannot be controlled (nor eliminated) from the field test environment, the NRSC's TGWG has concluded that the most important of these, the audio processing element, must be implemented in a controlled fashion if meaningful results are to be obtained from any informal field test audio quality assessments.

To understand this consider that, as just discussed, the field tests will use the programming from numerous *operational* radio stations, whose normal station practice is to design audio processing to project station “image” and overcome inherent problems specific to their own transmission systems and propagation environments. This processing, while vital for station operation, becomes a huge distraction when the goal is to compare the performance of analog and digital audio systems for a particular broadcast plant. In particular, with this customized processing in use, it is important to note that any comparison between the station's analog audio and its IBOC digital audio may be more a comparison of audio processors than it will be of transmission systems.

This situation can be made more workable, from a subjective evaluation standpoint, if the station under test agrees to use (for its analog signal) a processor with settings “matched” to the processor and settings used for the IBOC digital signal path, during the time periods when field test data is being collected. In this manner, the dynamic characteristics of the two systems (analog and digital) will be as close as possible, thereby eliminating one of the most prominent distractions as a variable. This situation is described pictorially in Figure 1. Alternatively, it may be possible to process the IBOC digital audio using audio processing parameters similar to

those used for the analog signal. A proponent choosing to perform this test is encouraged to work with the manufacturer of the processing equipment to produce this “match.”

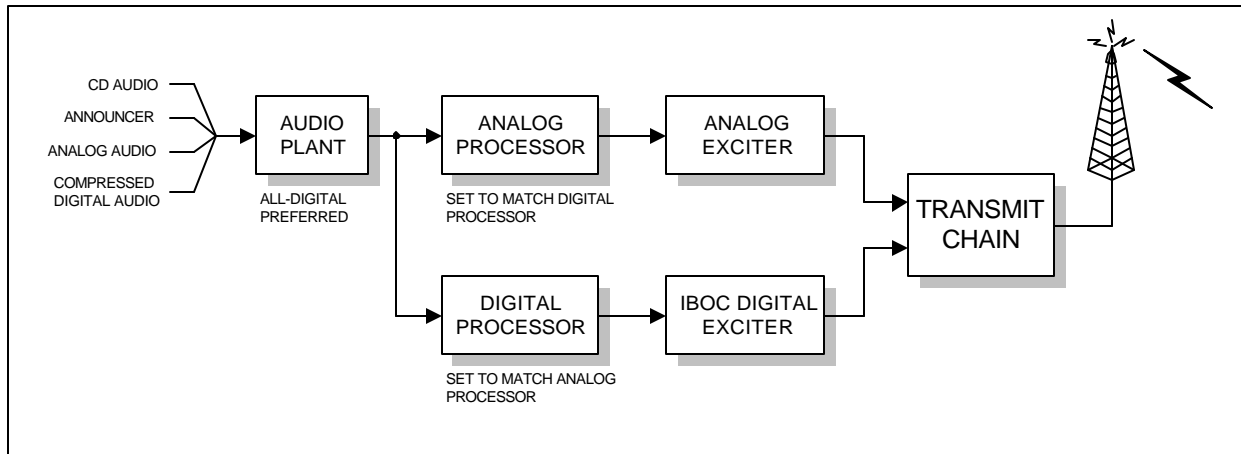

Figure 1. Suggested audio processor configuration to facilitate informal subjective evaluation of field test audio.

It must be emphasized that this matching of analog and digital processors is being suggested ONLY to foster the fairest comparison possible between the analog and digital systems, and as a way of reducing the variables inherent in these test environments so as to isolate the effects of the transmission systems on audio performance. This should not be seen as suggesting that any system needs to be operated in any specific manner during normal broadcast operations. Having said that, it must also be pointed out that without such processor matching, it would be virtually impossible to derive any meaningful information regarding subjective audio quality, informal or otherwise, from the comparison of collected field test audio.

5 Field test guidelines

Table 5-1 and Table 5-2 below summarize the field test guidelines for IBOC systems (FM-band and AM-band portions, respectively).

Proponents are referred to Appendices A and B which contain suggested test procedures for field tests. These procedures are recommended but not required, and have been developed by the TGWG specifically for these guidelines. Some additional comments are in order regarding field testing:

- Systems should be tested in the configuration(s) to be used for conventional broadcast service i.e. if the system were in actual commercial (or otherwise) operation. This comment applies in particular to transmitter configurations e.g., use of single versus multiple antennas (FM IBOC especially) and analog/digital signal combiners.
- System tests should exercise and demonstrate all modes of operation in particular all modes which are activated as conditions at the receiver site become degraded.
- For AM system tests, stations of different classes and representative of different antenna configurations (non-directional, directional) should be included in the field test program.

Table 5-1. Field Test Guidelines Summary – IBOC system, FM-Band portion

SECTION	TEST NO.	DESCRIPTION
5.1.1	A	Calibration
5.1.2	B	Strong signal with low interference
5.1.3	C	Single interferer
5.1.4	D	Two interferers

Table 5-2. Field Test Guidelines Summary – IBOC system, AM-Band portion

SECTION	TEST NO.	DESCRIPTION
5.2.1	A	Calibration
5.2.2	B	System performance within protected contour and low interference (day)
5.2.3	C	System performance within protected contour (day and night)

5.1 FM-band portion

5.1.1 Test A - System Calibration

Purpose: To constantly maintain IBOC system hardware and associated test equipment in a known, calibrated state, and to establish clear and complete documentation of that state; and, to establish the interference conditions, by calculation and measurement, along field test routes.

Desired results:

- 1) Average and peak RF power measurements of analog and IBOC signals, at exciter and high-power amplifier (HPA) outputs (total average digital power in the case of IBOC digital signals);
- 2) RF spectrum plot at combiner output showing shape and spectral occupancy of IBOC signal;
- 3) Digital audio subjective performance baseline—using “Threshold of Audibility” (TOA) or some other subjective criteria—versus additive white Gaussian noise (AWGN) or weak signal;
- 4) Baseline characterization of system digital performance, both digital audio and data transmission paths (BER, FER, or other similar parameter) versus AWGN or weak signal;
- 5) Analog transmission system test results (frequency response, distortion characteristics of main channel audio, synchronous AM noise characterization, etc.);
- 6) Transmit and receive antenna and RF distribution system performance data, including specifications, installation description, swept data (vs. elevation and azimuth), etc.;
- 7) Calibration record of equipment used for testing;
- 8) Interference levels (calculated and measured) along field test routes.

Comments:

- Systems should be calibrated regularly to insure precise and accurate test data;
- Suggested settings for RF spectrum plots – RES BW 1 kHz, sweep span 2 MHz (transmission line test);
- Proponents should provide assurance that entire transmission link, from audio source to antenna, is functioning according to good engineering standards;
- Multiple data points (BER, FER, etc.) should be collected so as to allow for performance versus carrier-to-noise ratio data plots;
- Other desired data (needed for full analysis and interpretation of results):
 - Continuous 500 kHz span spectrum plot recordings
 - Visual recording depicting the test environment
 - Digital recording of IBOC audio, analog audio (refer to Appendix C for analog receiver guidelines)
 - Digital error rate performance metric (IBOC audio path, data transmission path)
- Calibration records should be signed and dated.

5.1.2 Test B – Strong signal with low interference

Purpose: To characterize the **digital audio** and **data transmission** performance of the IBOC system in a low interference environment and in an environment where multipath interference is the predominant form of interference; and, to characterize the **host compatibility** and **analog subcarrier compatibility** under these conditions.

Desired results:

- 1) System performance in test area(s) with low multipath. Preferred test route(s) are from weak to strong desired signal.
- 2) System performance in test area(s) with strong multipath. Preferred test route(s) are in areas of moderate desired signal level, and include occurrences of “stoplight” fades.
- 3) Impact of IBOC signal presence on host main channel audio signal (i.e. host compatibility).
- 4) Impact of IBOC signal presence on host analog 67 kHz and 92 kHz subcarrier signals (i.e. analog subcarrier compatibility).

Comments:

- For these tests, any 1st adjacent analog signals should be at least 10 dB below the **digital** signal throughout the test area; and, any 2nd adjacent analog signals should be no more than 20 dB above the host analog signal.
- For strong multipath tests, route(s) should include some terrain obstructions with delays between 13 and 18 μ sec, and, collected data should include very slow-speed test runs.
- For host compatibility tests, IBOC analog station broadcasting classical music with conservative analog processing preferred; and, fixed location tests using receivers with PLL stereo decoders recommended.
- For subcarrier compatibility tests, spectrum plots of the subcarrier receiver input (spanning 1 kHz -100 kHz) should be obtained, both in the presence and absence of IBOC digital signal (off-air or transmission line sample of composite signal).
- For each test, objective data (e.g., BER, FER, etc.) on both digital audio and data transmission paths, and impairment data (e.g., TOA, POF, etc.) on digital audio and analog audio desired; refer to Appendix C for analog receiver guidelines.
- Multiple data points (BER, FER, etc.) should be collected so as to allow for performance versus carrier-to-noise ratio data plots.
- Other desired data (needed for full analysis and interpretation of results):
 - Continuous 1 MHz span spectrum plot recordings
 - Visual recording depicting the test environment
 - Digital recording of IBOC audio, analog audio
 - Digital error rate performance metric (IBOC audio path, data transmission path)

5.1.3 Test C – Single interferer

Purpose: To characterize the **digital audio** and **data transmission** performance of the IBOC system in the presence of a single first adjacent channel interferer.

- Desired results:
- 1) System performance in test area(s) with a single first adjacent channel interferer (at FCC limit) and low levels of multipath interference. Preferred test route(s) along path where desired signal averages close to the signal level expected at the protected contour, and interferer averages 6 dB below desired signal level.
 - 2) Same as 1) except with moderate to strong levels of multipath interference.
 - 3) System performance in test area(s) with a single first adjacent channel interferer (above FCC limit). Preferred test route(s) along path where desired signal averages close to the signal level expected at the protected contour, and interferer averages 12 dB above desired signal level.
 - 4) Same as 2) except with moderate to strong levels of multipath interference.

- Comments:
- For these tests, any additional 1st adjacent analog signals (besides primary interferer) should be at least 25 dB below the digital signal throughout the test area; and, any 2nd adjacent analog signals should be no more than 20 dB above the host analog signal.
 - Suggest that D/U ratio along test route be calculated and measured, and that a comparison of these data be submitted along with results.
 - For each test, objective data (*e.g.*, BER, FER, etc.) on both digital audio and data transmission paths, and impairment data (*e.g.*, TOA, POF, etc.) on digital audio and analog audio desired; refer to Appendix C for analog receiver guidelines.
 - Multiple data points (BER, FER, etc.) should be collected so as to allow for performance versus carrier-to-noise ratio data plots.
 - Other desired data (needed for full analysis and interpretation of results):
 - Continuous 1 MHz span spectrum plot recordings
 - Visual recording depicting the test environment
 - Digital recording of IBOC audio, analog audio
 - Digital error rate performance metric (IBOC audio path, data transmission path)

5.1.4 Test D – Two interferers

- Purpose: To characterize the **digital audio** and **data transmission** performance of the IBOC system in the presence of two simultaneous first adjacent channel analog interferers, and in the presence of two simultaneous second adjacent channel IBOC interferers.
- Desired results:
- 1) System performance in test area(s) with two simultaneous first adjacent channel interferers (at FCC limit) and low levels of multipath interference. Preferred test route(s) along path where desired signal averages close to the signal level expected at the protected contour, and interferers averages 6 dB below desired signal level.
 - 2) Same as 1) except with moderate levels of multipath interference.
 - 3) System performance in test area(s) with two simultaneous second adjacent channel interferers and low levels of multipath interference. Preferred test route(s) along path where interferers average 20 to 40 dB above desired signal level.
 - 4) Same as 3) except with moderate levels of multipath interference.
- Comments:
- For the first adjacent channel interference tests, it may be helpful to establish a low power station operating with special temporary authority to achieve the desired interference environment.
 - For the second adjacent channel interference tests, suggest that at least one test run proceed from a low interference area into the area where interferers are 20 to 40 dB above desired signal level.
 - Suggest that D/U ratio along test route be calculated and measured, and that a comparison of these data be submitted along with results.
 - For each test, objective data (*e.g.*, BER, FER, etc.) on both digital audio and data transmission paths, and impairment data (*e.g.*, TOA, POF, etc.) on digital audio and analog audio desired; refer to Appendix C for analog receiver guidelines.
 - Multiple data points (BER, FER, etc.) should be collected so as to allow for performance versus carrier-to-noise ratio data plots.
 - Other desired data (needed for full analysis and interpretation of results):
 - Continuous 1 MHz span spectrum plot recordings
 - Visual recording depicting the test environment
 - Digital recording of IBOC audio, analog audio
 - Digital error rate performance metric (IBOC audio path, data transmission path)

5.2 AM-band portion

5.2.1 Test A - System Calibration

Purpose: To constantly maintain IBOC system hardware and associated test equipment in a known, calibrated state, and to establish clear and complete documentation of that state; and, to establish the interference conditions, by calculation and measurement, along field test routes.

Desired results:

- 1) IBOC analog and digital power at transmitter output (read separately, if possible);
- 2) RF spectrum plot at combiner output showing shape and spectral occupancy of IBOC signal;
- 3) Digital audio subjective performance baseline—using “Threshold of Audibility” (TOA) or some other subjective criteria—versus AWGN or weak signal;
- 4) Baseline characterization of system digital performance, both digital audio and data transmission paths (BER, FER, or other similar parameter) versus AWGN or weak signal;
- 5) Analog transmission system test results (frequency response, distortion characteristics of analog audio channel, etc.);
- 6) Transmit and receive antenna and RF distribution system performance data, including specifications, installation description, swept data (vs. elevation and azimuth), etc.;
- 7) Calibration record of equipment used for testing;
- 8) Interference levels (calculated and measured) along field test routes.

Comments:

- Systems should be calibrated regularly to insure precise and accurate test data;
- Recommended spectrum analyzer settings – in accordance with FCC 73.44, with sufficient span to include 3rd order intermodulation products;
- Proponents should provide assurance that entire transmission link, from audio source to antenna, is functioning according to good engineering standards;
- Multiple data points (BER, FER, etc.) should be collected so as to allow for performance versus carrier-to-noise ratio data plots;
- Other desired data (needed for full analysis and interpretation of results):
 - Continuous spectrum plot recordings (at least 50 kHz span), to include total spectrum of 2nd adjacent channels
 - Visual recording depicting the test environment
 - Digital recording of IBOC audio, analog audio (refer to Appendix C for analog receiver guidelines)
 - Digital error rate performance metric (IBOC audio path, data transmission path)
- Calibration records should be signed and dated.

5.2.2 Test B – System performance within protected contour and low interference (day)

Purpose: To characterize the **digital audio** and **data transmission** performance of the IBOC system in a low interference environment and in an environment where fading due to ground conductive structures is the predominant form of interference; and, to characterize the **host compatibility** under these conditions.

Desired results:

- 1) System performance in test area(s) with low interference and low fading. Preferred test route(s) are from strong to weak desired signal.
- 2) Daytime system performance in test area(s) with multiple fades caused by ground conductive structures. Preferred test route(s) are from strong to weak desired signal.
- 3) Same as 2) except for nighttime service.
- 4) Impact of IBOC signal presence on host main channel audio signal (i.e. host compatibility).

Comments:

- For these tests, throughout the test area, any 1st adjacent analog signals should be at least 20 dB below the host analog signal; and, any co-channel analog signals should be at least 30 dB below the host analog signal.
- For host compatibility tests, IBOC analog station broadcasting music and talk and using moderate processing preferred.
- For each test, objective data (*e.g.*, BER, FER, etc.) on both digital audio and data transmission paths, and impairment data (*e.g.*, TOA, POF, etc.) on digital audio and analog audio desired; refer to Appendix C for analog receiver guidelines.
- Multiple data points (BER, FER, etc.) should be collected so as to allow for performance versus carrier-to-noise ratio data plots.
- Other desired data (needed for full analysis and interpretation of results):
 - Continuous 50 kHz span spectrum plot recordings
 - Visual recording depicting the test environment
 - Digital recording of IBOC audio, analog audio
 - Digital error rate performance metric (IBOC audio path, data transmission path)

5.2.3 Test C - System performance within protected contour (day and night)

Purpose: To characterize the **digital audio** and **data transmission** performance of the IBOC system within the entire day and night contour, when subjected to 1st-adjacent channel interference and in an environment where fading due to ground conductive structures exists.

Desired results:

- 1) System performance over entire day coverage area, including test area(s) subject to 1st-adjacent channel interference. Preferred test route(s) are from strong to weak desired signal.
- 2) Same as 1) except for nighttime service (over entire night coverage area).
- 3) Same as 1) in test area(s) with multiple fades caused by ground conductive structures.
- 4) Same as 3) except for nighttime service.

Comments:

- 1st adjacent analog signals should be at least 6 dB below the desired signal at points within the day contour.
- For each test, objective data (*e.g.*, BER, FER, etc.) on both digital audio and data transmission paths, and impairment data (*e.g.*, TOA, POF, etc.) on digital audio and analog audio desired; refer to Appendix C for analog receiver guidelines.
- Multiple data points (BER, FER, etc.) should be collected so as to allow for performance versus carrier-to-noise ratio data plots.
- Other desired data (needed for full analysis and interpretation of results):
 - Continuous 50 kHz span spectrum plot recordings
 - Visual recording depicting the test environment
 - Digital recording of IBOC audio, analog audio
 - Digital error rate performance metric (IBOC audio path, data transmission path)

Appendix A. Recommended Field Test Outline – FM-band

IBOC FIELD TEST GUIDELINES – FM

February 9, 1999

Test Objectives

1. Assess system performance with low multipath, low interference, and weak to strong signal.
2. Assess performance with strong multipath, low interference, and strong signal.
3. Spot-check home receiver compatibility (PLL stereo decoder) in strong signal areas at fixed sites on station that is broadcasting classical music with conservative processing.
4. Spot-check 67 kHz and 92 kHz analog subcarrier performance at same strong signal sites tested for home receiver compatibility.
5. Assess system performance with a single 1st adjacent interferer and moderate to strong multipath.
6. Assess IBOC performance with two first adjacent analog interferers.
7. Evaluate IBOC digital performance with two-second adjacent (IBOC) interferers at or near FCC maximum allowed interference level.
8. Assess digital and analog impairments.

IBOC FIELD TEST GUIDELINES – FM BAND					
REVISION #3a February 9, 1999					
Test Group	Test & Frequency	TEST PROCEDURE	Type of Evaluation	Signal Conditions	Test Results
A Calibration	1. Power (at the start and end of test period or as needed)	1. IBOC analog and digital power will be read separately at the output of the combiner (total average digital). 2. The digital average and peak power will be measured at the output of the digital exciter and through the digital amplifier. 3. A common analog/digital-transmitting antenna is strongly recommended. If separate antennas are used comprehensive field analog to digital power ratio measurements are recommended. 4. With separate transmitting antennas the analog to digital power ratio will vary in the field. Because this will have an effect on analog compatibility, step B.3 should be expanded to at least 50 test sites based on a grid.	Objective	NA	Analog/digital power levels Peak to average power ratios at exciter and HPA outputs
	2. Spectrum (daily)	1. Spectrum analyzer plots of the system RF spectrum will be taken at the output of the combiner. 2. The spectrum analyzer settings will be: RES BW 1 kHz, and sweep span 2 MHz (transmission line test).	Objective	RF signal level at least –45 dBm	Daily power ratios and out-of-channel radiation measured at output of combiner
	3. Weak signal (weekly)	1. TOA should be found at the output of the digital transmitter using a weak signal or noise added test. The test should be performed using an attenuator with at least 1 dB per step. 2. Impairment or program audio may be used.	EO&C	Signal level variable	Daily check on system performance
	4. Proof (beg. and end of test period)	An analog transmission system test should be conducted using a high quality FM demodulator.	Objective	FM transmitter output	Record of frequency response, separation, and distortion for the test record
	5. Monitor calibration	The analog FM modulation monitors should be calibrated using Bessel nulls. If Bessel nulls are not used, a description of the test procedure should be included in the proponent report.	Objective	FM transmitter output	Calibration results recorded in record
	6. Transmitting antenna performance and data	Antenna data to be supplied with report: 1. Transmitting antenna specifications. 2. The results of a recent antenna sweep. 3. Antenna installation description (PA to antenna).	Objective	NA	Record of transmitting antenna performance.
	7. Receiving antenna performance and data	1. Each proponent should supply a detailed description of the receiving antenna and RF distribution system. 2. Receiving antenna should be tested on a certified test range. 3. If any active RF device is used, a full set of RF performance tests results should be supplied with the report.	Objective	NA	Antenna plots and data
	8. Data to be reported	1. Continuous 500 kHz (span) spectrum plots recordings. 2. Visual recording depicting the test environment. 3. Digital recording of IBOC audio. 4. Digital recording of analog signal. The in motion receivers should be automotive type, one with aggressive blend and the second with conservative blend (see figure). The home type fixed receivers should use conventional PLL stereo decoder. 5. Error rate performance metric recorded during test run.	Objective EO&C	NA	Needed for full analysis and interpretation of results
	9. Interference	1. The specified interference levels (D/U) will be calculated. 2. The interference levels should be measured along the test route.	Objective	As specified in test	Calculated and measured D/U ratios vs. location

IBOC FIELD TEST GUIDELINES – FM BAND					
REVISION #3a February 9, 1999					
Test Group	Test	TEST PROCEDURE Objectives: <ul style="list-style-type: none"> System performance without interference System performance with multipath and no other interference “Stoplight” fade performance Host analog compatibility Subcarrier compatibility Note: 1. Mobile tests to be conducted at speed limit or with traffic flow. 2. Digital recordings will be made of all compatibility receiver tests.	Type of Evaluation	Signal Conditions	Test Results
B Strong signal with low interference	1. Low multipath	1. This test should be conducted in an FM station’s coverage area where the 1 st adjacent analog signal is at least 10 dB below the digital signal. With a host analog to digital power ratio of 22 dB, the analog D/U would be 35 dB. 2. The undesired analog second adjacent D/U should not exceed a D/U of –20 dB in the test area. 3. Digital program material may be the same as analog. Program material should include segments that will not mask digital impairments. 4. If impairments are not heard, the above runs should be repeated with the signal attenuated until impairments are heard.	EO&C audio impairments in field or by digital recording. Digital error rate performance metric	Weak to strong signal area with low interference. (not to exceed 69 dBu)	System performance with minimum interference Digital error rate performance metric for run Step B.1.4 is unnecessary if the error rate performance metric is included
	2. Strong multipath	1. Test in strong areas where the interference is no worse than in B.1.1 and B.1.2. The test environment should include some terrain-obstructed routes with strong delay between 13 and 18 microseconds. 2. Additional tests in multipath areas at very slow speeds (<u>less than 1 mph with frequent stops</u>). 3. Digital program material may be the same as analog. Program material should include segments that will not mask digital impairments. 4. If impairments are not heard, the above runs should be repeated with the signal attenuated until impairments are heard.	EO&C audio impairments in field or by digital recording Digital error rate performance metric	Moderate signal area with low interference (not to exceed 66 dBu)	System performance with multipath Digital error rate performance metric for run Step B.2.4 is unnecessary if the error rate performance metric is included
	3. Host Compatibility	1. <u>Fixed</u> compatibility tests should be conducted using receivers with conventional PLL (switching) stereo decoders. 2. The digital signal should be switched on and off at a rate that will allow the observers to rate possible interference. 3. Compatibility tests should be conducted using an IBOC analog station broadcasting classical music with conservative analog processing. 4. Digital recordings should be made of the analog audio for further subjective evaluation.	Subjective	Strong signal area (at least 70 dBu)	Subject rating of interference using the five step CCIR impairment scale
	4 Subcarrier	1. At the above compatibility test sites the 67 kHz and 92 kHz analog subcarrier audio S/N should be measured with the digital signal switched on and off. (67 kHz filter data to follow) 2. With normal station audio modulation (including subcarriers) and using a wideband receiver, plot the baseband noise from 1 kHz to 100 kHz with the IBOC signal on and off.	Objective	Strong signal area (at least 70 dBu)	Subcarrier S/N with and without the digital signal Plots of any variation in noise floor with the IBOC signal

IBOC FIELD TEST GUIDELINES – FM BAND

REVISION #3a February 9, 1999

Test Group	Test	Test Procedure Objective: System performance with first adjacent interference Notes: 1. Test route desired and undesired signal levels should be reviewed (measured) prior to test runs and compared to predicted values. 2. Test to be conducted at speed limit or with traffic flow.	Type of Evaluation	Signal Conditions	Test Results
C Single interferer	1. Single first adjacent analog calculated near FCC (6dB D/U) With moderate to strong MP	1. Test runs should be in areas where the calculated 1st adjacent interference averages 6 dB below the desired. The desired signal level should average close to the signal level expected at the protected contour. 2. Any other first adjacent interference should be at least 25 dB below desired signal and analog 2nd adjacent no higher than 20 dB above the desired FM. 3. Digital program material may be the same as analog. Program material should include segments that will not mask digital impairments.	EO&C audio impairments in field or by digital recording Digital error rate performance metric	Signal level average 60 dBu	System performance with first adjacent interferers Record any impairments or changes in audio quality Digital error rate performance metric for run
	2. Strong first adjacent	Test C.1 should be repeated in areas where the interference averages 12 dB higher than the desired composite signal (D/U –12 dB).	EO&C audio impairments in field or by digital recording Digital error rate performance metric	Signal level average 60 dBu	System performance with single channel Record any impairments or changes in audio quality Digital error rate performance metric for run

IBOC FIELD TEST GUIDELINES – FM BAND					
REVISION #3a February 9, 1999					
Test Group	Test	Test Procedure Objectives: <ul style="list-style-type: none"> • System performance with two adjacent channel interferers • System performance with varying levels of interference Notes: 1. Test route desired and undesired signal levels should be reviewed (measured) prior to test runs and compared to predicted values. 2. Tests to be conducted at speed limit or with traffic flow.	Type of Evaluation	Signal Conditions	Test Results
D Two interferers	1. Two 1st adjacent analog interferers Moderate MP	1. Test runs should be in areas where the calculated 1st adjacent interference averages 6 dB below the desired. The desired signal level should average close to the signal level expected at the protected contour. One analog interferer should be an existing station, and the second may be a low power station operating with a temporary authorization. 2. The test vehicle should make at least one run that starts with a low interference area and extends to the test area described in step D.1.1. 3. Digital program material may be the same as analog. Program material should include segments that will not mask digital impairments.	EO&C audio impairments in field or by digital recording Digital error rate performance metric	Signal level average 60 dBu D.1.2 signal varying	System performance with two 1st adjacent interferers Digital error rate performance metric for run
	2. Two 2nd adjacent IBOC interferers Moderate MP	1. Test runs should be in areas where the calculated 2nd adjacent composite IBOC interference average is at least 20 to 40 dB above the desired . 2. The test vehicle should make at least one run that starts with a low interference area and extends to the test area used in step D.2.1. 3. Digital program material may be the same as analog. Program material should include segments that will not mask digital impairments.	EO&C audio impairments in field or by digital recording Digital error rate performance metric	Signal level average 60 dBu D.2.2 signal varying	System performance with two 2nd adjacent interferers Digital error rate performance metric for run

Appendix B. Recommended Field Test Outline – AM-band

IBOC FIELD TEST GUIDELINES – AM

February 17, 1999

Test Objectives

1. Assess system performance with low interference and strong to weak signal levels.
2. Assess performance with fading and low interference.
3. Spot-check analog receiver compatibility.
4. Assess system performance with daytime interference.
5. Assess system performance with station nighttime operation within the protected contour.
6. Assess sky-wave performance.
7. Assess digital/analog audio impairments.
8. At least one directional station should be used for the tests.

IBOC FIELD TEST GUIDELINES – AM BAND

REVISION #2a February 17, 1999

Test Group	Test & Frequency	TEST PROCEDURE	Type of Evaluation	Signal Conditions	Test Results
A Calibration	1. Power (at the start and end of test period or as needed)	1. Where possible IBOC analog and digital power will be read separately at the output of the transmitter. 2. If this is not practical, the power ratios will be measured with a spectrum analyzer.	Objective	NA	Analog/digital (all) power levels Peak to average power ratios
	2. Spectrum (daily)	1. Spectrum analyzer plots of the system RF spectrum will be taken at the output of the combiner. 2. The spectrum analyzer will be set up in accordance with FCC 73.44, with sufficient span to include 3rd order intermodulation products.	Objective	RF signal level at least 2 mV	Daily power ratios and out-of-channel radiation measured at output of combiner
	3. Weak signal (weekly)	1. TOA should be found at the output of the digital transmitter using a weak signal or noise added test. The test should be performed using an attenuator with at least 1 dB per step. 2. Impairment or program audio may be used.	EO&C	Signal level variable	Daily check on system performance
	4. Proof (beginning and end of test period)	1. An analog transmission system test should be conducted using a high quality AM demodulator. 2. Host AM transmitter should use NRSC pre-emphasis.	Objective	AM transmitter output	Record of frequency response and distortion
	5. Monitor calibration	Monitor manufactures recommended procedure or certified lab.	Objective	AM transmitter output	Calibration results recorded in record
	6. Transmitting antenna performance and data	Antenna data to be supplied with report: 1. Transmitting antenna specifications. 2. The results of a recent proof. 3. Day and night detailed characteristics.	Objective	NA	Record of transmitting antenna performance for day and night operations
	7. Receiving antenna performance and data	1. Each proponent will supply a detailed description of the receiving antenna and RF distribution system to compatibility receivers and test equipment. 2. If any active RF device is used, a full set of RF performance tests will be supplied with the report.	Objective	NA	Antenna plots and data
	8. Data reporting	1. Continuous spectrum plots video recorded (at least 50 kHz span), to include total spectrum of 2nd adjacent channels. 2. Visual recording depicting the test environment. 3. Digital recording of IBOC audio. 4. Digital recording of analog signal. Two in motion receivers to be automotive type (narrow band and NRSC). 5. Error rate performance metric recorded during test run.	Objective EO&C	NA	Needed for full analysis and interpretation of results
	9. Interference	1. The specified interference levels (D/U) will be calculated. 2. The interference levels should then be <u>measured</u> along the test route. 3. Characterize AM band RF propagation conditions. 4. Record weather conditions at time of test (temp, rain, fog, snow, etc).	Objective	As specified in test	Calculated and measured D/U ratios vs. location Propagation, weather conditions

IBOC FIELD TEST GUIDELINES – AM BAND

REVISION #2a February 17, 1999

Test Group	Test	TEST PROCEDURE Objectives: <ul style="list-style-type: none"> • System performance without interference • System performance with fading and low AM station interference • Host analog compatibility Note: <ol style="list-style-type: none"> 1. Mobile tests to be conducted at speed limit or with traffic flow. 2. Tests should be repeated for all proposed transmission bit rates. 3. Digital recordings will be made of the digital and analog compatibility receivers' audio for all test runs. 	Type of Evaluation	Signal Conditions	Test Results
B System performance within protected contour and low interference (day)	1. Low fading	<ol style="list-style-type: none"> 1. These tests should be conducted in the test station's coverage area where the 1st adjacent interference is at least 20 dB below the desired analog, and co-channel analog interference is at least 30 dB below desired analog. 2. Digital program material may be the same as analog. Program material should include segments that will not mask digital impairments. 3. The first adjacent interference should be measured, and the co-channel D/U measured or estimated. 	EO&C audio impairments in field or by digital recording. Digital error rate performance metric	From strong to weak signal areas	System performance with minimum interference Digital error rate performance metric for run
	2. Fading	<ol style="list-style-type: none"> 1. These tests should be conducted in areas where desired stations' signal has multiple fades caused by ground conductive structures, with the interference no worse than in test B.1.1. 2. Digital program material may be the same as analog. Program material should include segments that will not mask digital impairments. 3. Tests should be repeated with station nighttime service. 4. The first adjacent interference should be measured, and the co-channel D/U measured or estimated. 	EO&C audio impairments in field or by digital recording Digital error rate performance metric	From strong to weak signal areas	System performance with fading Digital error rate performance metric for run
	3. Host Compatibility	<ol style="list-style-type: none"> 1. Compatibility tests should be conducted using two conventional AM receivers, one narrow band and one NRSC (see figure). 2. The digital signal should be switched on and off at a rate that will allow observers to rate possible analog interference. 3. Compatibility tests should be conducted using an IBOC analog station broadcasting music and talk and using moderate processing. 4. Digital recordings should be made of the analog audio for further evaluation. 	Subjective	Strong and moderate signal area	Subject rating of interference using the five-step CCIR impairment scale.

IBOC FIELD TEST GUIDELINES – AM BAND

REVISION #2a February 17, 1999

Test Group	Test	TEST PROCEDURE Objectives: <ul style="list-style-type: none"> • System performance within entire day and night contour • System performance with fading and within the day contour Note: <ol style="list-style-type: none"> 1. Mobile tests to be conducted at speed limit or with traffic flow. 2. Tests should be repeated for all proposed transmission bit rates. 3. Digital recordings will be made of the digital and analog compatibility receivers' audio for all test runs. 	Type of Evaluation	Signal Conditions	Test Results
C System performance within protected contour (day and night)	1. Low fading	<ol style="list-style-type: none"> 1. These tests should be conducted in the AM station's <u>entire</u> day coverage area. 2. The station selected should have at least one first adjacent interferer at least 6 dB below the desired signal at points within the day contour. 3. Digital program material may be the same as analog. Program material should include segments that will not mask digital impairments. 4. Tests should be repeated with station nighttime service. 5. The first adjacent interference should be measured, and the co-channel D/U measured or estimated. 	EO&C audio impairments in field or by digital recording. Digital error rate performance metric	Signal within coverage contour From strong to weak signal areas	System performance with day interference Digital error rate performance metric for run
	2. Fading	<ol style="list-style-type: none"> 1. Test in areas with multiple fades caused by ground conductive structures with interference similar to interference in B.1. 2. Digital program material may be the same as analog. Program material should include segments that will not mask digital impairments. 3. Tests should be repeated with station nighttime service. 4. The first adjacent interference should be measured, and the co-channel D/U measured or estimated. 	EO&C audio impairments in field or by digital recording Digital error rate performance metric	Signal within coverage contour From strong to weak signal areas	System performance with fading Digital error rate performance metric for run

Appendix C. Analog Receiver Selection (Field Testing)

A critical aspect of field test planning involves the selection of the analog receivers to be used. These receivers will have a profound influence on the comparison being made between the digital and analog services, as well as the results of the compatibility tests (i.e. determining the effect that IBOC DAB has on existing analog main channel audio signals).

The NRSC recommends that proponents use commercially-available analog receivers representative of a cross-section of receivers in use by consumers since, during the initial and transitional phases of IBOC DAB service introduction, these are the receivers which will primarily be in use, and therefore of primary interest with respect to analog compatibility.

In previous NRSC IBOC DAB tests, five FM and three AM radios were selected for use in compatibility testing, listed in Table C-1.³ For FM, radios were selected from four categories: auto, portable, home Hi-Fi (high end), and home Hi-Fi (competitive). Two automobile radios were selected because of their large consumer populations and because of their dramatically different stereo-to-mono "blend" implementations. These auto radios also showed high adjacent channel rejection. The portable and personal portable use similar circuitry and have less adjacent channel rejection. The high end home Hi-Fi radios had good 2nd adjacent channel rejection, but exhibited first adjacent channel rejection characteristics similar to that found in the portable and home radios.

Table C-1. Analog Receivers Used in NRSC IBOC DAB Tests (1995)

CATEGORY	MAKE & MODEL	FM	AM
Auto	Delco model # 16192463	✓	✓
Auto	Ford model #F4XF-19B132-CB	✓	
Portable	Panasonic RX-FS430	✓	✓
Home Hi-Fi (high end)	Denon TU-380RD	✓	✓
Home Hi-Fi (competitive)	Pioneer SX-201	✓	

For mobile testing of FM IBOC systems, the NRSC strongly urges proponents to use both of the auto radios included in Table C-1. This is vital because of the characteristics just mentioned in the previous paragraph, that is, their significant performance differences combined with their widespread usage by consumers.

Additional information is provided below on the FM band performance of these auto receivers. Figure C-1 illustrates the measured separation vs. RF level. Note in particular the difference in behavior between the Ford and the Delco radios, with the Delco first achieving a 10 dB separation between the left and right channels at an RF level 27 dB below that of the Ford.

³ See "Consumer Electronics Group, Electronic Industries Association, Digital Audio Radio Laboratory Tests - Transmission Quality Failure Characterization and Analog Compatibility, August 11, 1995" for additional information, in particular, Appendix H which contains characterization data on the receivers in Table C-1.

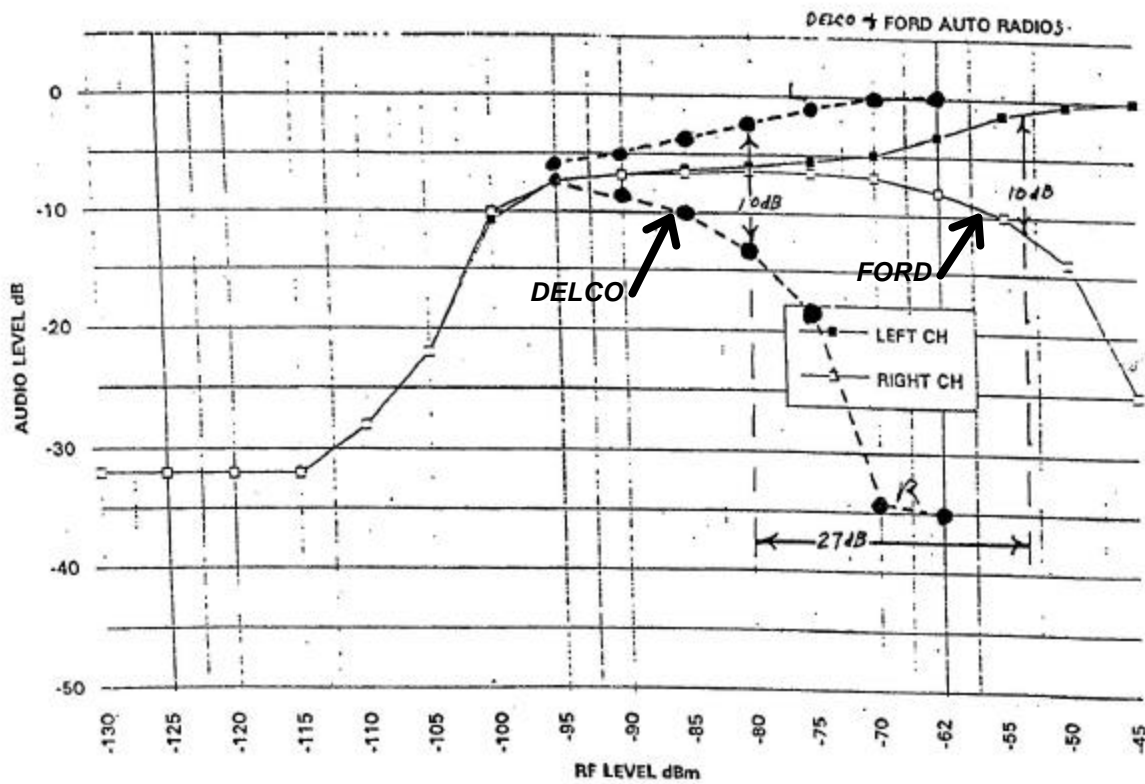

Figure C-1. Separation vs. RF Level - Delco and Ford Auto Radios (FM band)

In table C-2, the total harmonic distortion (THD) and stereo S/N performance of these two radios is shown, for moderate RF input levels.

Table C-2. FM Auto Radio Performance

RECEIVER	THD (AT -50 dBm)	STEREO S/N RMS (AT -62 dBm)
Delco	2% (at least 35 dB separation)	59 dB (35 dB separation)
Ford	1% (14 dB separation)	66 dB (5 dB separation)

Likewise, for AM IBOC tests, proponents should make use of at least two analog receivers. Figures C-2 and C-3 illustrate the frequency response of the Delco radio (AM band) by itself, and plotted along with the NRSC 75 μsec standard deemphasis curve, respectively.

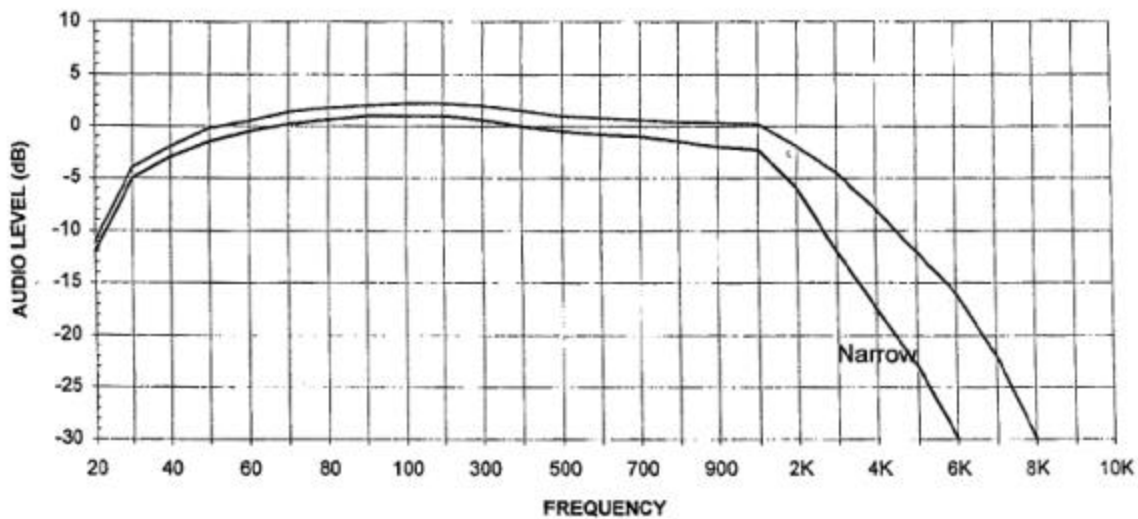

Figure C-2. AM Frequency Response - Delco Radio (narrow and wide settings)

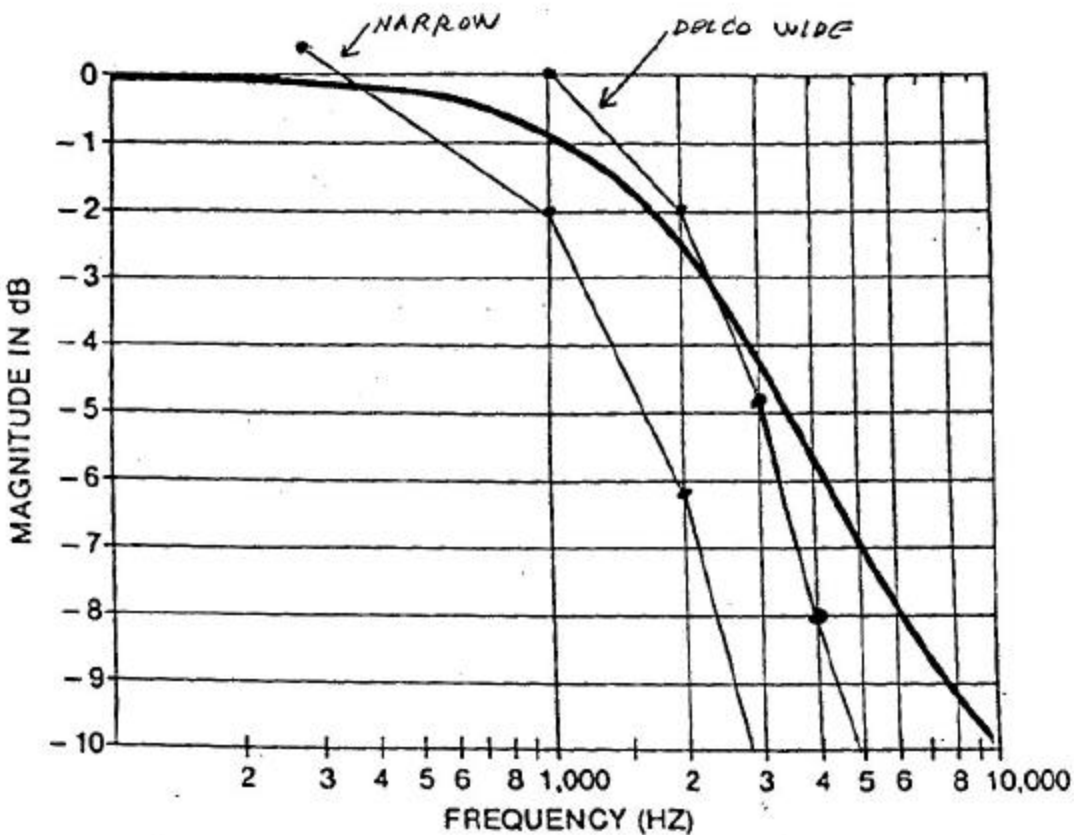

Figure C-3. Delco Radio Frequency Response Compared to 75 msec AM Standard Deemphasis Curve

Appendix D. Test Matrix – Field Test Guidelines, FM-band Portion

FIELD TESTS, FM-BAND PORTION					INTERFERENCE			COMMENTS
TEST	DESCRIPTION	AWGN	FIXED	MOBILE	FADING	1ST-ADJ	2ND-ADJ	
A	System calibration							
1)	Average and peak RF power measurements		✓					
2)	RF spectrum plot		✓					
3)	Digital audio subjective performance baseline	✓	✓					
4)	Baseline characterization of system digital performance	✓	✓					
5)	Analog transmission system test results							
6)	Transmit and receive antenna, RF distribution system performance data							
7)	Calibration record of equipment							
8)	Interference levels (calculated and measured) along test routes			✓				
B	Strong signal with low interference							
1)	Low multipath		✓	✓	✓			<ul style="list-style-type: none"> • Negligible interference from co- and adjacent-channels • Digital, analog audio impairment performance • Data transmission performance
2)	Strong multipath		✓	✓	✓			
3)	Host main channel audio compatibility		✓	✓				
4)	Host analog 67 kHz and 92 kHz subcarrier compatibility		✓	✓				
C	Single interferer							
1)	Single 1st-adjacent channel interferer (at FCC limit)			✓		✓		<ul style="list-style-type: none"> • Negligible interference from add'l 1st and 2nd adjacent channels • Digital, analog audio impairment performance • Data transmission performance
2)	Single 1st-adjacent channel interferer (at FCC limit) with multipath			✓	✓	✓		
3)	Single 1st-adjacent channel interferer (above FCC limit)			✓		✓		
4)	Single 1st-adjacent channel interferer (above FCC limit) with multipath			✓	✓	✓		
D	Two interferers							
1)	Two simultaneous 1st-adjacent channel interferers (at FCC limit)			✓		✓		<ul style="list-style-type: none"> • Digital, analog audio impairment performance • Data transmission performance
2)	Two simultaneous 1st-adjacent channel interferers (at FCC limit) with multipath			✓	✓	✓		
3)	Two simultaneous 2nd-adjacent channel interferers			✓			✓	
4)	Two simultaneous 2nd-adjacent channel interferers (with multipath)			✓	✓		✓	

Appendix E. Test Matrix – Field Test Guidelines, AM-band Portion

FIELD TESTS, AM-BAND PORTION					INTERFERENCE			COMMENTS
TEST	DESCRIPTION	AWGN	FIXED	MOBILE	FADING	1ST-ADJ	2ND-ADJ	
A	System calibration							
1)	Average and peak RF power measurements		✓					
2)	RF spectrum plot		✓					
3)	Digital audio subjective performance baseline	✓	✓					
4)	Baseline characterization of system digital performance	✓	✓					
5)	Analog transmission system test results							
6)	Transmit and receive antenna, RF distribution system performance data							
7)	Calibration record of equipment							
8)	Interference levels (calculated and measured) along test routes			✓				
B	System performance within protected contour and low interference (day)							
1)	Low interference (daytime)		✓	✓				<ul style="list-style-type: none"> • Negligible interference from co- and adjacent-channels • Digital, analog audio impairment performance • Data transmission performance
2)	Performance with fading (daytime)		✓	✓	✓			
3)	Performance with fading (nighttime)		✓	✓	✓			
4)	Host main channel audio compatibility		✓	✓				
C	System performance within protected contour (day and night)							
1)	Daytime performance over entire day coverage area.		✓	✓		✓		<ul style="list-style-type: none"> • Negligible interference from add'l 1st and 2nd adjacent channels • Digital, analog audio impairment performance • Data transmission performance
2)	Nighttime performance over entire nighttime coverage area.		✓	✓		✓		
3)	Daytime performance over entire day coverage area with fading.		✓	✓	✓	✓		
4)	Nighttime performance over entire nighttime coverage area with fading.		✓	✓	✓	✓		

Appendix F. Suggested Field Test Assessment Data Logging Conventions and Reporting Form

Recommended FM and AM Field Test Assessment datalogging conventions are provided in Table F-1. In Figure F-1, a proposed field test data reporting form is offered. Also refer to the EIA DAR Subcommittee's field test report for additional examples of field test data reporting.

Table F-1. Suggested Field Test Assessment Datalogging Conventions

Notes:

- See also test groups A-8 in Appendices A and B.
- Recommended data to be recorded during field test runs:
 - Time
 - Vehicle speed
 - Digital audio
 - Analog audio (two receivers recommended)
 - Signal level
 - Digital error rate performance metric
 - Location and landmarks

No	DESCRIPTION OF DATA	PERFORMANCE GRADING
1	Continuous spectrum analyzer plots (1 MHz span for FM, 50 kHz span for AM)	Digital signal interference and transmission conditions: 0 No interference 1 Single 1st adjacent 11 Upper and lower 1st adjacent 12 1st and 2nd adjacent 2 Single 2nd adjacent 22 Upper and lower 2nd adjacent 3 Low signal 4 Multipath
2	Visual recording depicting test environment	Note type of environment associated with impairments: U Urban UO Urban obstructed S Suburban UO Suburban obstructed R Rural RO Rural obstructed
3	Digital recording of IBOC audio	Grade dynamic digital impairments: 0 Imperceptible 1 Perceptible (-) 2 Failure (=)
4	In-motion digital recording of analog receiver audio	Grade dynamic analog impairments: 0 Imperceptible 1 Perceptible (-) 2 Very annoying/no signal (=)

DRAFT
February 17, 1999

Field Test Reporting Form

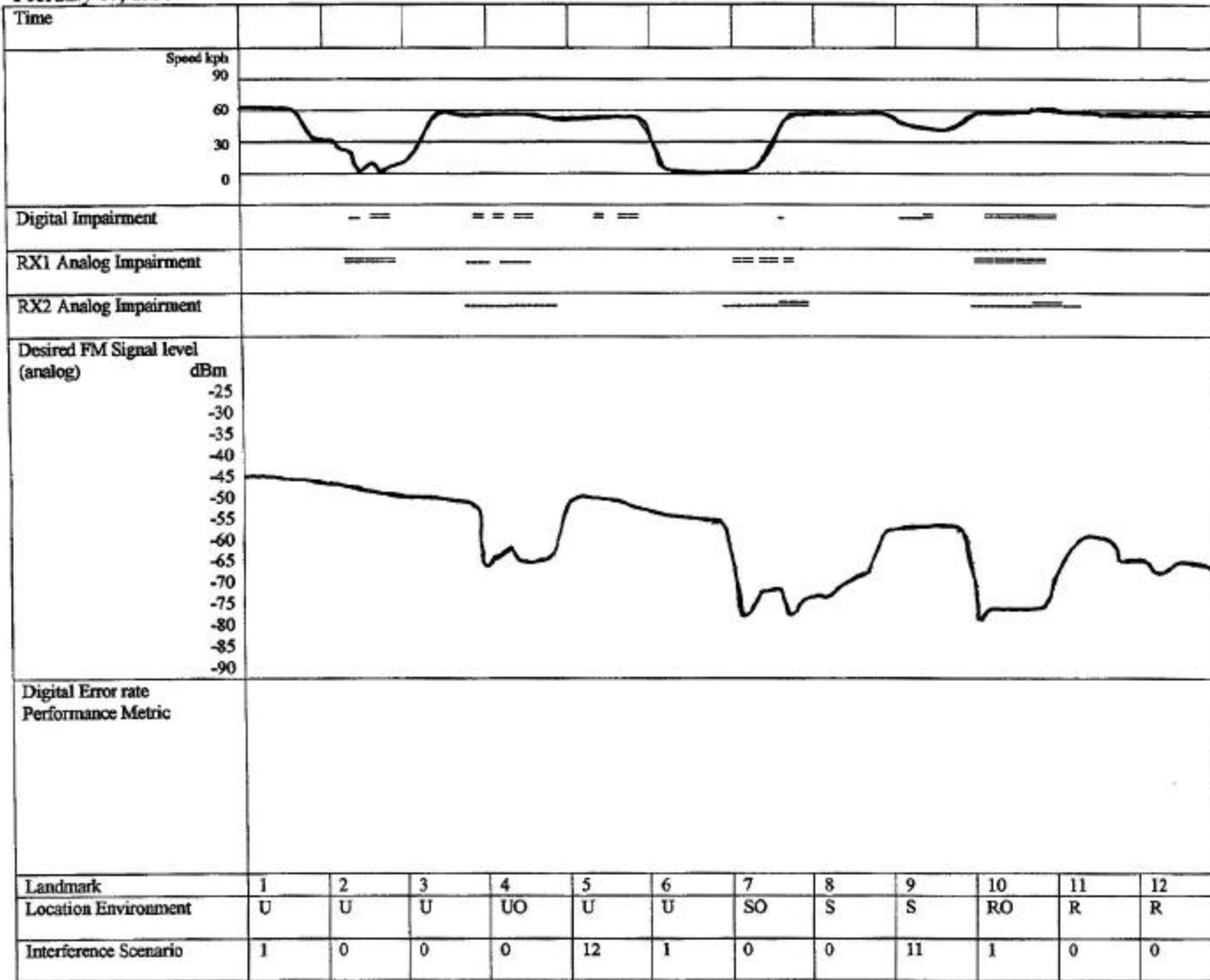

Figure F-1. Suggested Field Test Data Reporting Form

Appendix G. DAB Subcommittee Goals & Objectives



2500 Wilson Boulevard
Arlington, VA 22201-3834
(703) 907-7500
FAX (703) 907-7501

NATIONAL RADIO SYSTEMS COMMITTEE



1771 N Street, NW
Washington, DC 20036-2891
(202) 429-5346
FAX (202) 775-4981

5/14/98

DAB Subcommittee

Goals & Objectives

(as adopted by the Subcommittee on May 14, 1998)

Objectives

- (a) To study IBOC DAB systems and determine if they provide broadcasters and users with:
- A digital signal with significantly greater quality and durability than available from the AM and FM analog systems that presently exist in the United States;
 - A digital service area that is at least equivalent to the host station's analog service area while simultaneously providing suitable protection in co-channel and adjacent channel situations;
 - A smooth transition from analog to digital services.
- (b) To provide broadcasters and receiver manufacturers with the information they need to make an informed decision on the future of digital audio broadcasting in the United States, and if appropriate to foster its implementation.

Goals

To meet its objectives, the Subcommittee will work towards achieving the following goals:

- (a) To develop a technical record and, where applicable, draw conclusions that will be useful to the NRSC in the evaluation of IBOC systems;
- (b) To provide a direct comparison between IBOC DAB and existing analog broadcasting systems, and between an IBOC signal and its host analog signal, over a wide variation of terrain and under adverse propagation conditions that could be expected to be found throughout the United States;
- (c) To fully assess the impact of the IBOC DAB signal upon the existing analog broadcast signals with which they must co-exist;
- (d) To develop a testing process and measurement criteria that will produce conclusive, believable and acceptable results, and be of a streamlined nature so as not to impede rapid development of this new technology;
- (e) To work closely with IBOC system proponents in the development of their laboratory and field test plans, which will be used to provide the basis for the comparisons mentioned in Goals (a) and (b);
- (f) To indirectly participate in the test process, by assisting in selection of (one or more) independent testing agencies, or by closely observing proponent-conducted tests, to insure that the testing as defined under Goal (e) is executed in a thorough, fair and impartial manner.

**Appendix D –
IBOC DAB System Evaluation Guidelines**



2500 Wilson Boulevard
Arlington, VA 22201-3834
(703) 907-7500
FAX (703) 907-7501

NATIONAL RADIO SYSTEMS COMMITTEE



1771 N Street, NW
Washington, DC 20036-2891
(202) 429-5346
FAX (202) 775-4981

(draft 9/27/99)

DAB SUBCOMMITTEE IBOC DAB System Evaluation Guidelines

Addendum #1 Additional suggestion for data formatting

This addendum provides additional information regarding how proponents format data included in an IBOC system data submission to the NRSC. Proponents are asked to consider the information in this addendum as they prepare their submission.

The NRSC's Test Guideline documents request a considerable amount of information taken under numerous conditions in both the laboratory and the field. For the purpose of clarity and to promote an efficient evaluation by the NRSC, it would be helpful if as part of a submission a proponent were to summarize (when appropriate) system performance using the tabular format shown below. This information is especially valuable when provided at the "edge of coverage" or when it represents "point of failure" performance.

TEST	MODE INFORMATION			FER	AVG. CODER RATE	OPTIONAL		
	ANALOG/ DIGITAL	DATA PATHS IN USE	TBD			MOS	S/N	Host/INTF.

where:

- Test – description of test being reported;
- Mode information – information provided by the proponent per Addendum 4 to the Laboratory and Field test guidelines – note that this information is proponent specific and each proponent may present different information here (three examples are shown: Analog/digital – for systems which “blend to analog;” Data paths in use – for systems with multi-level (i.e. multidescriptive) source coding schemes; and TBD – for other relevant mode information not previously disclosed;
- FER – Frame error rate measured during test (e.g., average FER);
- Avg. coder rate – the average effective source coder rate for the test
- Optional – Other useful information about the test, such as: MOS – the results of any subjective evaluations performed on the data for this test; S/N – signal to noise ratio of received RF signal; and, Host/Intf – the power ratio of the host to any interfering signals present.



2500 Wilson Boulevard
Arlington, VA 22201-3834
(703) 907-7500
FAX (703) 907-7501

**NATIONAL
RADIO
SYSTEMS
COMMITTEE**



1771 N Street, NW
Washington, DC 20036-2891
(202) 429-5346
FAX (202) 775-4981

D A B S u b c o m m i t t e e

**In-band/On-channel (IBOC)
Digital Audio Broadcasting (DAB)
System Evaluation Guidelines**

*(as adopted by the Subcommittee on April 17, 1999
and revised on May 25, 1999)*

Table of contents

1	INTRODUCTION	3
2	PROCESS OVERVIEW	7
2.1	PRE-SUBMISSION MEETINGS	7
2.2	DATA SUBMISSION	9
2.3	DATA ANALYSIS.....	9
2.4	REPORT GENERATION.....	9
2.5	DAB SUBCOMMITTEE ADOPTION.....	9
2.6	PROPONENT COMMENTS.....	9
2.7	FINAL REPORT RELEASED	10
3	DATA FORMATTING.....	11
4	DATA ANALYSIS	12
4.1	SYSTEM COMPROMISES.....	12
4.2	BASELINE ANALOG PERFORMANCE	13
4.2.1	<i>Audio quality (IBOC digital audio).....</i>	<i>13</i>
4.2.2	<i>Service area</i>	<i>14</i>
4.2.3	<i>Durability.....</i>	<i>15</i>
4.2.4	<i>Acquisition performance</i>	<i>16</i>
4.2.5	<i>Auxiliary data capacity.....</i>	<i>16</i>
4.2.6	<i>Performance at the edge of coverage.....</i>	<i>16</i>
4.3	POTENTIAL DEGRADATION TO HOST ANALOG SIGNAL.....	16
4.4	AUDIO RECORDINGS	17
5	REPORT GENERATION.....	19
5.1	QUALITATIVE FACTORS AND PERFORMANCE GOALS	19
5.2	REPORT STRUCTURE	19
APPENDIX A – QUALITATIVE FACTORS AND PERFORMANCE GOALS.....		20
APPENDIX B – DAB SUBCOMMITTEE GOALS & OBJECTIVES		26

1 Introduction

The radio industry in the United States is on the brink of a revolution called Digital Audio Broadcasting (DAB). DAB promises to bring the missing piece to the analog-to-digital transition the radio industry's infrastructure is undergoing, turning radio into a *truly* digital medium poised for competition with other digital media.

A revolutionary change like this should not be undertaken lightly. Any technology developed for this purpose must be carefully, thoroughly, and objectively examined, considering both technological and economic aspects.

For a variety of reasons, in-band/on-channel (IBOC) DAB represents an attractive approach for broadcasters to introduce DAB in the United States. IBOC technology, now having been through several generations of development, appears to be reaching the point where it may be both feasible and ready for serious consideration. Design work continues by three independent IBOC system proponents and a regulatory process began in November 1998 when the FCC released for comment a Petition for Rulemaking on IBOC DAB, the first time ever this topic had been the subject of a formal proceeding.¹

The NRSC's DAB Subcommittee—an industry-sponsored technical standards setting group composed of broadcasters, receiver manufacturers, and other allied concerns—has been working for the last year and a half with all interested IBOC technology developers to put in place a process which will allow it to assess this latest generation of IBOC and in particular, to determine if it can provide broadcasters and users with:

- A digital signal with significantly greater quality and durability than available from the AM and FM analog systems that presently exist in the United States;
- A digital service area that is at least equivalent to the host station's analog service area while simultaneously providing suitable protection in co-channel and adjacent channel situations;
- A smooth transition from analog to digital services.²

After considerable deliberation, the NRSC has decided that the first phase of its process will involve establishing the extent to which these individual IBOC systems meet these criteria. To that end, the Test Guidelines Working Group (TGWG) of the DAB Subcommittee drafted a series of test guideline documents outlining the recommended test procedures and technical

¹ See FCC RM-9395, "Amendment of Part 73 of the Commission's Rules to Permit the Introduction of Digital Audio Broadcasting in the AM and FM Broadcast Services."

² From "DAB Subcommittee Goals & Objectives," as adopted by the Subcommittee on May 14, 1998.

data that the NRSC needs to make such a determination, and describing the requirements a system submission must meet in order to be evaluated by the NRSC.³

The System Evaluation Guidelines document, a product of the NRSC's DAB Subcommittee Evaluation Working Group (EWG), Dr. H. Donald Messer, Chairman, is a companion to those test guidelines documents. Included herein is information on the process that the EWG intends to follow in the evaluation of technical data submitted to the NRSC by IBOC proponents. As with the test guidelines documents, this document is the result of a cooperative effort between broadcasters, receiver manufacturers, and IBOC system developers.

In the sections that follow, frequent reference is made to the test guidelines documents. Consequently, it is recommended that the test guidelines documents be reviewed thoroughly prior to consideration of this document. In some cases, the material contained herein expands upon that already presented in the test guidelines documents.

A number of other baseline assumptions, in addition to those presented in the test guidelines, underlie the evaluation guidelines which follow and are listed here along with a brief explanation. Some of these points will be further expanded upon in subsequent sections.

- System evaluation is self-contained – The DAB Subcommittee's objectives as given above focus on the comparison of an IBOC system's performance to that of existing analog radio services. It is not the intention of the NRSC to perform any "cross-system" comparisons at this time. Each system submitted will be evaluated on its intrinsic technical performance and its performance compared against existing analog services. A separate report will be prepared on each IBOC system submitted for evaluation.

Since IBOC proponents are conducting their own test programs and are believed to be testing independently from one another, and since proponents are free to follow their own test procedures (those included in the test guidelines documents mentioned above are only recommendations), it would be difficult or impossible to perform meaningful cross-system comparisons. A test program designed to directly compare different IBOC systems would of necessity involve common test elements that are not present in the current NRSC process.

- Comparison with analog services – A major thrust of this evaluation process is the comparison of IBOC digital audio with existing AM and FM main channel audio. By and large, this comparison will utilize analog audio obtained by a proponent during its test program that, as is discussed in the test guidelines, will have been subjected to the same conditions as the digital portion of the signal.

³ See "DAB Subcommittee – IBOC DAB System Test Guidelines – Part I – Laboratory Tests," adopted by the Subcommittee on 12/3/98, and "DAB Subcommittee – IBOC DAB System Test Guidelines – Part II – Field Tests," adopted by the Subcommittee on 3/4/99.

- Focus of evaluation is on “hybrid” performance – Many feel that the ultimate goal of IBOC DAB is to establish the “all digital” radio broadcasting infrastructure of the future and that the “hybrid” IBOC DAB systems being developed represent a transitional stage between the existing analog and future all-digital systems. A number of system proponents have indicated that their current system designs address both the hybrid and all-digital aspects of IBOC, and consequently the NRSC may receive data submissions including information on both hybrid and all-digital system implementations.

In reality the transition from analog to digital radio broadcasting cannot be accomplished overnight. Even an IBOC system with an all-digital implementation included in its initial design is going to have to proceed through a lengthy transition phase during which the hybrid mode is going to be the principal mode of IBOC operation. Broadcasters, keenly aware of this, are especially concerned about how the hybrid IBOC signals are going to affect the existing analog signals which are the lifeblood of their businesses, particularly since the viability of a hybrid IBOC system meeting the DAB Subcommittee’s objectives has never been proven.

Furthermore, there is also a strong consensus within the broadcasting technical community that of the two IBOC DAB modes, hybrid and all-digital, implementation of the hybrid mode is at least if not more technically challenging than is the all-digital mode. Given all of these factors, the NRSC has found it appropriate to restrict the main focus of its current evaluation to hybrid IBOC DAB.

The emphasis placed on hybrid systems should not be interpreted as a lack of interest in all-digital IBOC DAB systems – the NRSC encourages proponents to integrate an all-digital design into their plans. The broadcast industry will benefit most from a system that can transition seamlessly from hybrid to all-digital. Proponents are encouraged to include information on their system’s hybrid to all-digital transition capabilities, and on all-digital system performance, as part of their submission to the NRSC and can expect the NRSC to review this information and comment on it in their final report.

For the present time and effort, the most pressing need is to evaluate the hybrid mode of performance. To focus on the all-digital mode now without a complete understanding of the performance and tradeoffs associated with the hybrid mode of operation would be premature.

- Attention to the test guidelines is crucial – The closer a proponent’s data submission comes to providing the information recommended in the test guidelines documents, the more likely it will be that the NRSC can achieve its evaluation objectives. A great deal of thought and untold years of experience in the technical aspects of broadcasting have gone into the preparation of the test guidelines documents. The NRSC believes that all of the requested data is important and necessary for a complete system evaluation. If a proponent’s submission lacks requested information, then the NRSC may find it difficult to reach a conclusion regarding that system’s suitability for deployment.

As is customary for NRSC projects, the dissemination of submitted IBOC system information will be coordinated by staff to interested DAB Subcommittee participants. The EWG

will serve as the focal point of the evaluation effort, under the direction of its Chairman, Dr. Messer, and the final evaluation report generated on a submission, when complete, will be released by this group to the DAB Subcommittee for formal adoption. Openness, fairness, and uniformity in evaluation of submissions will be at the forefront of the process, and will be incorporated into every aspect of system evaluation.

Another tenet of this process, and one that has been reinforced time and again by the IBOC proponents in their dialog within the NRSC, is that "time is of the essence." It is the NRSC's intention to begin processing any submission promptly upon receipt. Evaluation of a proponent's submittal will proceed in a manner that is consistent with the thorough and careful methods appropriate to a task of this importance. The NRSC's goal in this regard is not to delay but to accelerate the process of reaching important decisions about DAB deployment in the U.S.

2 Process overview

The system test guidelines documents contain a detailed explanation of the expected form and content of a proponent submission to the NRSC. This section of the System Evaluation Guidelines describes the NRSC's handling of a proponent's submission once received. Figure 1 of this guideline is a schematic representation of the NRSC evaluation process.

2.1 Pre-submission meetings

One of the NRSC's goals in conducting this evaluation program is that it proceed in an expedited fashion without sacrificing the quality of the evaluation. The primary purpose of the pre-submission meeting is to support this goal by ensuring that a proponent understands exactly what the test guidelines are requesting, and how their submission will be handled by the NRSC's evaluators, so that the form and content of a proponent's submission allows for as expedited a review as is possible.

Proponents are encouraged to contact the NRSC at any time during their testing process, especially if they have test guideline-related questions. Proponents must make contact 4 to 6 weeks prior to their planned submission date to arrange for (one or more) pre-submission meeting(s). Items to be covered at such a meeting include the following:

- Overview of proponent submission in particular, system description, test procedures followed, type of data being submitted (lab and/or field), data formatting, tests performed, identification of sub-contractors or consultants (*e.g.*, subjective evaluation facilities, consultants hired for independent verification of results), and identification of facilities used during tests (including broadcast facilities used for field testing).
- Update on NRSC evaluation process – In addition to the information contained in this evaluation guideline, there may be supplemental information on the evaluation process to convey.

During the pre-submission meeting(s), the proponent will meet with NAB and CEMA staff and their respective engineering consultants, and with the DAB Subcommittee and Evaluation Working Group Chairpersons. During the pre-submission review process, the following items in particular will be confirmed as being included in the proponent's submission:

- a) Detailed system description, including a discussion of the tradeoffs and compromises made between various system aspects (especially tradeoffs affecting audio quality, interference performance, coverage, and compatibility with the analog host main channel audio).
- b) Test procedure description, especially any deviations (including rationale) from the procedures recommended in the test guidelines documents.
- c) Statement of oversight/review – as discussed in the test guidelines, proponents are expected to retain an independent, third-party observer who will follow and/or review the system testing (done by the proponent) closely, and personally certify the submitted results as an accurate record of the actual measured system performance.

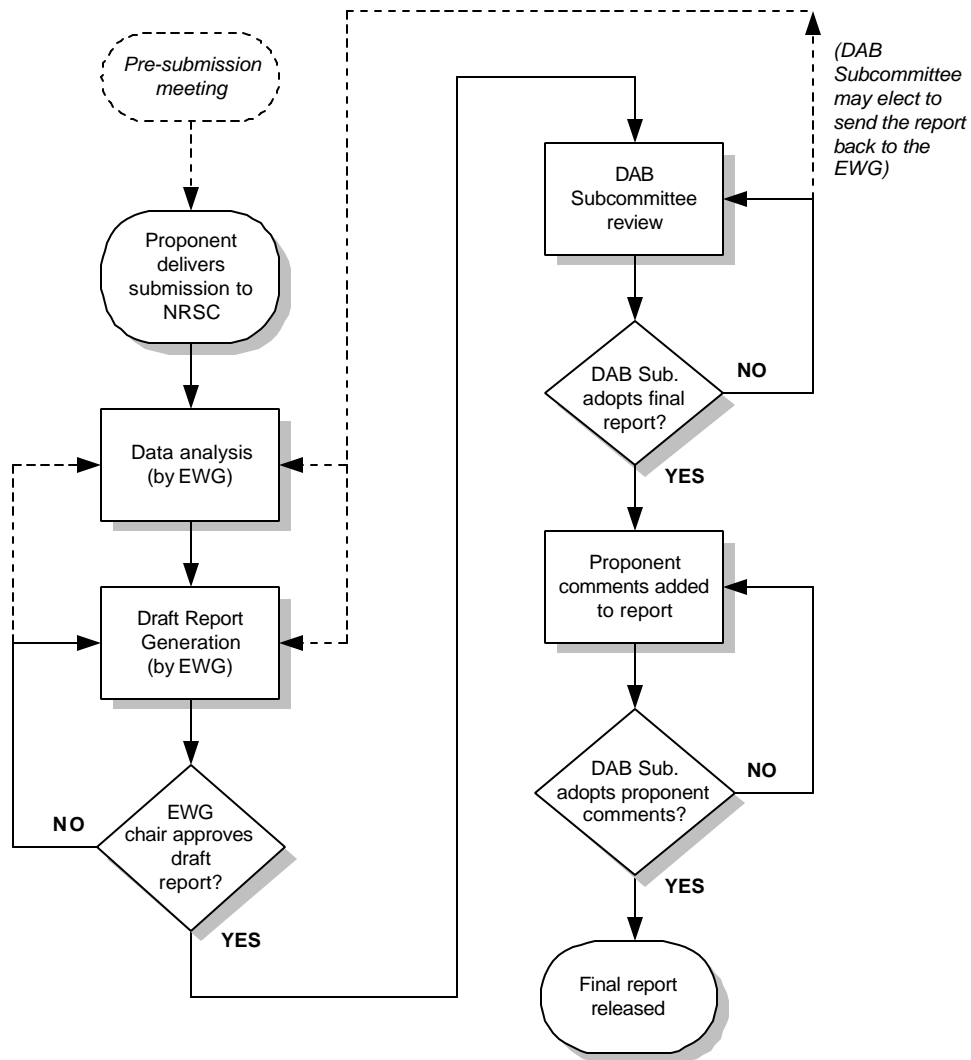

Figure 1. Schematic representation of the NRSC IBOC DAB system evaluation process

- d) Complete system submission, including IBOC DAB for both the AM and FM bands, and if not, rationale behind the omission of one band. (Note – the NRSC may elect not to evaluate a submission that does not accommodate both AM and FM bands.)
- e) Test results represent performance of completed system (not interim or preliminary results).
- f) A sufficient quantity of test result data such that a meaningful evaluation can be performed. The test matrices portions of the test guidelines (Appendices D and E in Parts I and II) will be utilized in this determination.

An early dialog on these matters between a proponent and the NRSC should help expedite the evaluation process.

2.2 Data submission

Once the pre-submission meeting has occurred, the next step is for the proponent to deliver their submission to the NRSC. Two copies of all materials should be prepared, with one copy being delivered to CEMA and one to NAB. Proponents will be expected to sign a release form upon submittal acknowledging their understanding of the evaluation process as outlined in this guideline. It will be the NRSC's policy to refer any requests it receives for additional copies of the submission (not including those needed for official Committee business) to the proponent.

If desired, a proponent can accompany their submittal with an oral presentation to the DAB Subcommittee, for the purpose of presenting the technical details of their system, or to highlight key results, etc. Such a presentation must be coordinated with NAB and CEMA staff at least 4 weeks prior to the desired presentation date.

2.3 Data analysis

A thorough analysis of the submission will be conducted by the EWG. Additional information on the analysis portion of the process is given below in the section entitled "Data analysis." The proponent whose submission is being considered will be expected to respond to inquiries from the EWG which are likely to arise as the submission is evaluated.

2.4 Report generation

The end product of the NRSC's evaluation will be a final report drafted by the EWG and referred to the DAB Subcommittee for formal adoption. As mentioned earlier, this report will discuss only the submitted system and its comparison with existing analog services; no comparisons with other digital audio transmission systems, IBOC or otherwise, will be contained in the report. Additional information on the report generation portion of the process is given below in the section entitled "Report Generation." As with the data analysis phase of system evaluation, proponent participation in the report generation phase of the process will be limited.

2.5 DAB Subcommittee adoption

After the EWG Chair is satisfied that the EWG final report on a system evaluation is complete, it will be sent up to the DAB Subcommittee for consideration. There, it will be discussed and debated and either formally adopted or sent back to the EWG for additional work.

2.6 Proponent comments

Upon formal adoption by the DAB Subcommittee, the proponent whose system was evaluated will be given an opportunity to officially comment on the adopted report and have those comments incorporated into the report itself as an appendix. The purpose of these

comments would be to explain specific results and/or further clarify or expand upon the conclusions stated in the report, including dissenting with or affirmation of those conclusions. These proponent comments are subject to DAB Subcommittee review and adoption.

2.7 Final report released

At the conclusion of this process, the evaluation report will be formally released to the public, including a formal submission jointly by CEMA and NAB to the FCC in any relevant IBOC DAB proceeding.

Note that EWG participants will be encouraged to withhold public statements regarding the evaluation of submissions until the process is complete, to minimize the possibility of pre-judgment or misunderstanding based on partial or incomplete information. The DAB Subcommittee chairman is the official spokesperson for all matters pertaining to the work of the EWG; all requests for information originating outside of the NRSC should be referred to that person.

3 Data Formatting

The format of a proponent submission, that is, the way in which the submitted information is organized and presented, will have a significant bearing on how rapidly and effectively the EWG can perform its evaluation. Proponents should bear this in mind as they prepare their material for submission and can expect that data formatting will be one of the topics discussed during their pre-session meeting(s) with the NRSC.

Since proponents are planning and executing their own test programs, the NRSC has no foreknowledge of the contents of proponent submissions, and consequently some of the data formatting suggestions being made in this document (as well as in the test guidelines) may not apply to a particular proponent submission. Proponents are free to assemble submissions as they see fit; ideally, a proponent submission will closely follow the organization of the pertinent test guidelines document. Proponents are asked to pay special attention to Appendices D and E (for both Part I and Part II) as they prepare their submissions and to organize the main body of the test data according to these test matrices.

Additional specific suggestions regarding submissions include the following:

- Recorded audio – the NRSC expects that proponents will use a variety of recording media for data collection including but not limited to digital audio tape (DAT) and digital recording directly onto hard disks and/or compact discs (CDs).

The preferred format for audio recording submission to the NRSC is linear CD audio with a sampling rate of 44.1 kHz. Use of the CD format minimizes or eliminates the possibility of alteration of the submitted material and allows the evaluators to make use of widely available, high-quality playback equipment. Alternatively, a proponent may elect to submit audio in DAT format.

The use of digital audio compression (for the purpose of bit rate reduction) at any point in the audio collection process would be inadvisable, and the NRSC assumes that the only digital audio compression existing in any submitted recordings is that of the IBOC perceptual audio coding system alone.

- Computer-based data – in the event that a proponent submits data in computer form, it should be in “machine-readable” format, using tabs, commas, or quotation marks to delimit the different fields of data. Spaces may also be used as a delimiter in combination with the delimiters identified above or, when on ambiguity would result, alone. Data may also be presented in any format that can be imported into a Microsoft Excel spreadsheet.

4 Data Analysis

The primary objective of the NRSC under its current IBOC evaluation effort is to establish whether or not an IBOC system outperforms existing analog technology, and if so, to what extent. The NRSC's ability to achieve this objective is enhanced if a proponent has followed the recommendations of the NRSC's test guidelines. Proponents are encouraged to actively participate in the NRSC process and to respond in a timely and forthcoming manner to EWG requests for additional information and clarification.

4.1 System compromises

It has become clear to the NRSC over time that a successful IBOC DAB technology is likely to involve a number of compromises and tradeoffs among key aspects of the system. For example, a proponent will have made decisions about the number of bits to allocate to source coding, and the number of bits to allocate to channel coding with this decision representing a tradeoff between audio quality and signal robustness. What is not clear at this point, and what a proponent's submission needs to establish, is exactly how and why the compromises for a given system were made, and the effect, if any, of these compromises on the analog and digital signals that will need to co-exist in the radio band.

Given this situation, and not knowing how a proponent is likely to deal with the numerous tradeoffs to be made, it is impossible for the NRSC to determine in advance exactly what set of tradeoffs result in an IBOC system with "significantly greater quality and durability" than existing analog systems. In the absence of measured system performance, such a determination would suffer from the following deficiencies:

- It would be arbitrary – for example, how would one decide how much additional coverage area for an IBOC signal represents significant improvement – 10%? 25%? Before such benchmarks can be set, one first needs to know the magnitude of improvement possible given the state of the art.
- There are so many factors to consider – if, for example, audio quality is improved significantly but digital coverage area is less extensive than is the case with existing analog technology, then could the overall performance be judged as significantly improved? Again, it would be impossible to reach such a conclusion without having first reviewed all of the performance data, to establish a benchmark.
- There are too many possible tradeoffs and compromises – if the NRSC were to try and quantify "significant improvement" before seeing any data, how could it decide among the myriad of tradeoffs and compromises possible? This would border on trying to design a proponent's system.

Only after a system's data has been evaluated and the technical performance pinned to a system's tradeoffs and compromises is known will it be possible to say if an IBOC system represents a significant improvement over analog services. Even then, such an assessment will

be challenging. Assessment of system tradeoffs is expected to be one of the EWG's more difficult tasks in evaluation.

4.2 Baseline analog performance

Given that it is not possible to quantify "significantly improved" performance prior to data analysis, the NRSC needs to quantify for proponents the baseline analog performance to which an IBOC system will be evaluated as this is much more tractable. Simply stated, baseline analog performance is the performance representative of today's analog services. Clearly, an IBOC system that is not at least as good as existing analog services would not be considered "significantly improved."

The following sub-sections discuss some of these key parameters. The task of the EWG will be to review each aspect of system performance for which data has been submitted and to determine whether or not the submitted IBOC system performance exceeds the corresponding baseline analog performance, and, if so, to what degree.

4.2.1 Audio quality (IBOC digital audio)

Characterization of the audio quality of a perceptually-coded system is hampered by the fact that key objective performance parameters such as signal-to-noise ratio and total harmonic distortion cannot be meaningfully applied to their analysis. Subjective evaluation against a signal with known properties is the best way currently available for evaluating the quality of perceptually coded audio.

Perhaps the best "historical" audio quality baselines for AM and FM radio are obtained from the NRSC's AMAX specification (for AM), and the (now retired) FCC rules for "proof of performance" (for FM), which stipulate minimum performance parameters for AM and FM shown in Table 1.

Table 1. Historical audio quality baseline performance for AM and FM analog radio (transmission plant specifications)

Parameter	AM	FM
Frequency response	Flat response (tolerance of +1.5/-3 dB) from 50 Hz to 7.5 kHz	Flat response (tolerance of ±1.5 dB) from 50 Hz to 15 kHz
THD	less than 2%	less than 1%
SNR	at least 50 dB	at least 60 dB
Stereo separation	N/A	at least 30 dB
(Source)	NRSC AMAX specification	Pre-1986 version of Section 73.1590 of the FCC Rules entitled "Equipment Performance Measurements"

These historical audio quality baselines are descriptions of the minimum performance expectations of the transmission systems, given perfect channel conditions and an ideal receiver. Many stations transmit signals that perform much better than these baseline values.

Because historical “proof of performance” baseline values do not represent what stations are capable of transmitting today, the NRSC feels that a comparison against audio obtained through reference chains (including receiver performance) is the fairest way to determine how the IBOC digital audio quality compares against existing services. As discussed in the laboratory system test guidelines, the NRSC recommends that proponents compare the digital audio quality of their systems against that obtained using the AM and FM NRSC reference chains. These reference chains are representative of the current state of the art of AM and FM radio. The NRSC reference chain performance parameters are given in Table 2.

4.2.2 Service area

Both AM and FM IBOC systems should provide a service area that, on a station-by-station basis, matches or exceeds the interference-limited service area of the host analog station. Station locations and, for FM stations only, antenna heights above average terrain for the IBOC facilities should be assumed to be the same as the host analog stations. IBOC systems should not require a change of the existing standards of allocation used in the domestic AM and FM broadcast services.

Table 2. NRSC reference chain audio quality baseline performance for AM and FM analog radio (total system performance including receiver)†

Parameter	AM	FM
Frequency response	[]	[]
THD	[]	[]
SNR	[]	[]
Stereo separation	[]	[]

† Values are currently being measured on the reference station equipment and will be included when available. Refer to the Laboratory Test Guidelines document for additional information on the NRSC reference chain.

Actual interference-free service areas are variable, depending on individual receiver characteristics. From a regulatory standpoint, interference-free analog service areas for FM stations are determined at the outer limit of FCC protected analog service on the basis of a co-channel desired-to-undesired (D/U) signal strength ratio of 20 dB, a first adjacent channel D/U of 6 dB, and a second and third adjacent channel D/U of -40 dB. Desired or service signal strength is based on median f(50,50) field strength, and the undesired or interfering signal strength is based on median f(50,10) field strength. The f(x,y) notation represents the field strength exceeded at x percent of locations y percent of the time.

The actual range of viable coverage, in the absence of interference, exceeds statutory limits for most receivers. The statutory outer limit of analog service in the absence of interference for FM stations varies with the class of the channel on which the FM station operates. For Class B FM stations, the outer limit is 54 dB μ V which corresponds to a median f(50,50) field strength of 0.5 millivolt per meter (mV/m). For Class B1 stations, the outer limit is 57 dB μ V which corresponds to a median f(50,50) field strength of 0.7 mV/m. For all other classes of FM station, the outer limit is 60 dB μ V which corresponds to a median f(50,50) field strength of 1.0 mV/m.

As with FM, the actual range of viable coverage for AM, in the absence of interference, exceeds statutory limits for most receivers. Daytime FCC protected interference-free analog service areas for AM stations are determined on the basis of a co-channel D/U of 26 dB at the desired 0.1 mV/m contour for Class A stations and the desired 0.5 mV/m contour for all other classes; a first adjacent channel D/U of 6 dB at the desired 0.5 mV/m contour; a second adjacent channel D/U of 0 dB at the desired 5 mV/m contour; and a third adjacent channel D/U of 0 dB at the desired 25 mV/m contour.

IBOC proponents should recognize that many AM stations, and especially those in rural areas, provide reliable daytime service out to their respective 0.5 mV/m contours. The outer limit of daytime analog service in the absence of interference for AM stations is assumed to be the 2 mV/m contour.

The outer limit of nighttime analog groundwave service for AM stations is the calculated nighttime interference-free contour. The signal strength at the nighttime interference free contour varies from station to station. An IBOC DAB system that provides reliable service during the daytime within a given analog service area is likely to provide adequate service at night within the analog nighttime interference-free contour.

While some AM stations provide a secondary nighttime service by skywave, the propagation characteristics of the channel become extremely time variant at night and impairments to satisfactory reception such as interference and fading become controlling factors. The impact of these time-variant changes in an AM channel at night on the performance of an IBOC DAB system will be considered.

The EWG will also consider the performance of IBOC DAB systems in geographic areas in and proximate to the nulls in AM directional antenna horizontal plane patterns. Frequency dependent phase changes and asymmetric narrowing of the AM channel bandwidth in and around nulls on the proper operation of IBOC systems will be of particular interest.

4.2.3 Durability

The durability of a radio signal is characterized by its ability to withstand interference from other radio signals (co-channel, 1st adjacent channel, and 2nd adjacent channel signals in particular) and to withstand the impairing effects of the channel. In FM, multipath fading is the predominant form of channel impairment, while for AM, atmospheric noise and the attenuation due to grounded structures are major impairments.

4.2.4 Acquisition performance

Radio listeners have an expectation, gained from their experience with existing analog services, that a radio once tuned to an active frequency will acquire the signal rapidly, usually in less than 1 second. While the NRSC recognizes that it may be difficult for a digital audio system, in particular one incorporating advanced signal processing algorithms for robustness, to acquire rapidly, it must nevertheless utilize the "less than one second" baseline of performance in evaluating these systems, since this is the kind of performance that consumer acceptance of this service will demand.

4.2.5 Auxiliary data capacity

Many industry observers have suggested that one of the most important benefits to be realized in adopting a DAB system is the intrinsic auxiliary data capacity (i.e. data capacity not used for the main channel digital audio signal) likely to be available. For existing FM, the NRSC considers a continuously available information rate of approximately 10 kbps to be the baseline performance for auxiliary data capacity. This represents the average data carrying capacity of the digital subcarrier technologies tested by the NRSC's High-speed FM Subcarrier Subcommittee in the 1995-1997 time frame.

For AM, auxiliary data services are not currently supported and hence there is no reasonable baseline of performance established. Consequently, any auxiliary data capacity at all for AM will represent a significant improvement, however, the NRSC suggests that the minimum usable capacity would be equivalent to that offered by the NRSC RBDS standard (an FM digital subcarrier standard) which is an information rate of approximately 700 bits/sec.

4.2.6 Performance at the edge of coverage

Some digital broadcasting schemes, for example, the ATSC DTV system, and the Eureka-147 DAB system, exhibit a "cliff-effect" failure at the edge of their service area. That is, they exhibit excellent performance as long as the signal level into the receiver is above some threshold value, but once it goes below this value, they stop functioning completely.

As with acquisition performance discussed earlier, an IBOC DAB systems performance at the edge of coverage could also have important ramifications as far as consumer acceptance of the service is concerned. Listeners have come to expect that a signal will degrade gradually, since this is the nature of existing radio services. The EWG will be paying close attention to this aspect of system performance as it examines a submission.

4.3 Potential degradation to host analog signal

Another issue the EWG needs to address is what level of potential degradation of the *host analog* signal of an IBOC system is acceptable. This gets to the very heart of how potential tradeoffs and compromises are to be considered in this evaluation process.

It may be necessary to tolerate some amount of degradation (with respect to existing services) in the analog host since there is now a new, "significantly improved" digital service component of the broadcast signal. It is difficult for the NRSC to state, before having analyzed the data, the level of degradation that may be considered acceptable.

Some of the IBOC system proponents view “hybrid” IBOC systems as a transition to an all-digital approach, and have indicated that these all-digital approaches will be integrated into their IBOC systems from the start. In these cases, a rationale might exist to accept a different level of degradation in the analog host during the hybrid period than if there were no integrated transition path to all-digital.

4.4 Audio recordings

The Test Guidelines documents make numerous references to submission of audio recordings in addition to the requests for written material such as test procedures, test data, system information, etc. These recordings will form an integral part of the NRSC’s evaluation and should be considered by proponents to be one of the more important items to be submitted.

Since a proponent’s submission is expected to include numerous subjective evaluation results of audio performance, for example, establishing unimpaired digital audio quality of their system, along with the other requested data, the NRSC does not intend to conduct further evaluations of this sort using the audio recordings it receives. However, it would be impossible for the NRSC to conduct a credible, thorough evaluation of a digital audio broadcasting system without reviewing the audio recordings that correspond to the submitted data on that system.

One aspect of expected NRSC audio recording review can be characterized as a “reality check,” giving evaluators an opportunity to hear and experience for themselves various aspects of a system’s performance as indicated in the data report. Some examples of this include the following:

- TOA, POF assessment – in laboratory impairment tests, proponents are asked to establish the “threshold of audibility (TOA)” and “point of failure (POF)” of their systems under various conditions. Audio recordings corresponding to the TOA and POF behavior will be vital so that evaluators can know exactly the characteristics of TOA and POF as used in the data report.
- Impairment observations – the field test guidelines suggest that proponents conduct “impairment observations” in a mobile reception environment, and further that they record both the analog (host) and digital audio signals being simultaneously received. While a written report on these impairments is extremely useful, evaluators will also need to listen to the recorded audio so that they can fully understand the nature of the impaired performance, and can properly interpret the written record.

An equally important but perhaps less tangible role fulfilled by audio recording review is that it gives the evaluators an opportunity to establish a “feel” for how a system sounds under the various conditions it was subjected to during testing. Audio recordings made during a carefully conducted system test, under carefully monitored conditions, with additional supplementary information available (such as received signal strength or simultaneously recorded analog audio), will be of far greater value to system evaluators than would audio

collected under less exacting conditions, such as the “demonstrations” conducted by proponents for the NRSC (and others) in the past.

By and large, EWG members are broadcasting industry professionals with years of experience and have spent considerable time and effort forming opinions about broadcast audio based on listening to it. One of the suggested audio materials in the lab test guidelines— the so-called “long-form” audio—was included so that broadcasters and receiver manufacturers could hear some “real-world” material, making it possible for them to better gauge how an IBOC system compares to existing analog services from a listening standpoint. Submission of long-form audio recordings from the lab tests, and audio-of-opportunity recordings from the field tests, will give them an opportunity to do this.

5 Report generation

Once data analysis is complete, and supplementary information included in a submission has been considered, the EWG will prepare a report summarizing its findings, including its determination of whether the IBOC system evaluated represents a significant improvement over existing services, if this determination can be made. Discussed in this section (and in Appendix A) of the Evaluation Guidelines document are some of the qualitative factors and performance goals which will be considered as the EWG attempts to make this determination, as well as some particular aspects of the report document itself.

5.1 Qualitative factors and performance goals

Upon reaching the report generation phase of the evaluation process, the EWG will have before it information on a system's design, laboratory and field test data (including audio recordings), and the results of the analysis performed on this data. The EWG, as it prepares its report, will review all of this information and reach a final conclusion as to whether a system represents a significant improvement over existing analog services. Discussed in Appendix A are some of the qualitative factors and performance goals the EWG will be considering as it conducts this review.

5.2 Report structure

Each IBOC system submitted for evaluation to the NRSC will be reported on individually. The EWG will strive to follow a common format, if it should have the opportunity to generate more than one report (due to the evaluation of more than one system), however, reports on different systems may be different due to differences existing in the various submissions.

Items to be included in the system evaluation report include the following:

- Results of data analysis – item by item and overall
- Conclusions – does the system represent a significant improvement over existing services?
 - If yes, an explanation of exactly how this is so
 - If no, then the reasons why not
- Dissenting opinions (if any) from participants (not proponents)

When the report is complete (as determined by the EWG Chair), it will be sent up to the DAB Subcommittee for consideration. There, it will be discussed and debated and either formally adopted or sent back to the EWG for additional work.

Upon formal adoption by the DAB Subcommittee, the proponent whose system was evaluated will be given an opportunity to officially comment on the adopted report and have those comments incorporated into the report itself as an appendix. The purpose of these comments would be to explain specific results and/or further clarify or expand upon the conclusions stated in the report, including dissenting with those conclusions. These proponent comments are subject to DAB Subcommittee review and adoption.

Appendix A – Qualitative Factors and Performance Goals

The overall performance goal is the improvement in fidelity and robustness of the transmission system. Proponents and evaluators should consider the overall transmission and listening experience weighed against the cost and complexity of the system when evaluating any of the specific performance goals listed in these guidelines. The success and acceptability of an IBOC system will be determined by how it meets the overall needs of the broadcaster, receiver manufacturer and the listener, as well as how it meets the performance goals specified in this document.

A.1 Qualitative Factors

A.1.1 Evaluation Categories

The EWG assumes that the comparison between a digital technology and its analog counterpart is based on the use of identical antenna locations and heights. Any change of existing standards of allocation necessary for a submitted IBOC system would bear upon this comparison and must be fully disclosed and explained by the proponent.

Described below are some of the current strengths and weaknesses of the analog AM and FM broadcasting services against which IBOC systems will be compared. Before discussing these characteristics of AM and FM broadcasting, three primary categories of evaluation are identified: fidelity, durability and flexibility.

A.1.1.1 Fidelity

“Fidelity” represents how well the input to the transmitter *can be* replicated at the output of a receiver. Consumer acceptance of an IBOC technology may be enhanced if the technology improves on the fidelity of analog AM and FM.

It is important to note that fidelity is defined in terms of what *can be* delivered to the listener. A number of variables will affect the audio a listener actually hears. Good fidelity, then, is a description of the upper bound of audio performance of a broadcast medium assuming ideal source material is sent under ideal transmission, propagation, reception and listening conditions. The subjective listening tests recommended in the test guidelines will provide information about how overall fidelity of a new digital technology compares with current analog technology.

A.1.1.2 Durability

Durability refers to the ability of the received program content to resist interruption and the ability of the received programs fidelity to resist being compromised by interference and channel impairments.

- Interference:

- Caused by co- or adjacent channel signals
- Impairments:
 - Environmental noise (man-made or atmospheric)
 - Shielding (structural or terrain shadowing)
 - Grounded conductive structures (e.g. obstructions that introduce amplitude and phase changes to the channel)
 - Multipath
 - Receiver motion
 - Receiver overload induced intermodulation products (e.g., blanketing)
 - Directional antenna pattern signal distortions

IBOC system evaluations will include an assessment of whether the coverage area and durability of an IBOC signal at least matches its analog host's coverage area and durability. The listening experience at both the central listening area and the edge of coverage must be examined. This examination will, at a minimum, look at the Threshold of Audibility (TOA) and Point of Failure (POF) throughout the coverage area.

Most stations in the United States are limited in coverage by co- and adjacent channel interference. This interference directly influences the coverage area of the analog and potentially the digital signals. Within the coverage area, durability will be affected by impairments which may so degrade the signal that listeners tune out.

An IBOC system's ability to survive both interference and impairments will directly affect public perception of this technology.

A.1.1.3 Flexibility

A technology's flexibility has both technical and economic components. The term flexibility is used here to represent the potential of a technology to be adapted by broadcasters and manufacturers to meet the needs of listeners and consumers. Currently, analog receiver manufacturers make a range of products tailored to the price and performance needs of different kinds of radio users. Automobile radios are optimized to provide the best mobile reception possible, while the ten dollar pocket radio sacrifices performance to maximize affordability. For IBOC systems, codec technologies, communications protocols, and receiver chipset requirements can influence the flexibility of the system designs.

Some of the different aspects of a technology's flexibility to consider include:

- Capability to support a diversity of receiver types with a diversity of features and cost;
- Capability to improve the technology and meet consumer expectations by the addition of backward-compatible enhancements;
- Capability to provide features and services to improve station-listener relationship;
- Capability to be forward compatible to allow migration to an all-digital mode.

A.2 Qualitative performance goals

A.2.1 Fidelity of transmission systems

A.2.1.1 Frequency response and distortion

Unlike with analog systems, there will be less opportunity to influence a digital transmission system once it is installed, therefore the best fidelity a digital system can offer will be highly dependent on the fundamentals of its design.

Performance goal: *For FM IBOC systems, the frequency response and distortion fidelity of a digital technology should be comparable to or better than the best FM transmission facilities in the country. AM IBOC systems should deliver a fidelity that approaches present FM analog fidelity.*

This next performance goal applies to FM-band IBOC and to a lesser degree, to AM-band IBOC as well.

Performance goal: *To alleviate the effects of channel impairments and interference, it may be acceptable to diminish distortion and frequency response fidelity to maintain audio free of dropouts and noticeable artifacts.*

A.2.1.2 Noise

An FM transmission system that meets the former FCC noise specifications (refer to Table 1, Section 4.2) has a noise fidelity that meets consumer requirements under optimum listening conditions. Again, AM transmission systems performance is not as good as FM in this regard. However, much source material now has better noise characteristics than the transmission system can deliver.

Broadcasters use audio processing to be more consistently audible under the variety of reception and listening conditions in the marketplace. This tends to maximize the instantaneous audio to noise ratio. Noise fidelity of FM under ideal reception conditions is therefore an acceptable level of performance. Noise fidelity of a new technology should strive to be equivalent to the performance of typical source material, such as CDs.

Performance goal: *To alleviate the effect of impairments and interference it may be acceptable to compromise noise fidelity to maintain audio free of dropouts and noticeable artifacts.*

A.2.1.3 Stereo separation

Good stereo separation is an important goal for any IBOC system but it should be recognized that its importance to the overall fidelity of a system may be masked by the limitations of the typical listening environment. It is generally accepted that stereo separation

of 35 dB is sufficient for the enjoyment of stereo in the ideal listening environment. This should remain a goal of new technologies. Certain receivers, listening environments, and listeners do not presently obtain this performance.

As a receiver is moved beyond the range of a full-quieting signal level, the stereo component begins to develop noise. Automobile radio manufacturers have ably adapted FM receiver design to manipulate the high frequency content and stereo separation to extend the tolerable range of mobile reception.

Performance goal: *In the digital domain, stereo separation is a characteristic of fidelity that may be acceptable to compromise in response to channel impairments.*

A.2.1.4 Fidelity characteristics of digital technologies

In the analog domain, fidelity may be affected by distortions in frequency (and phase) response, nonlinearities producing other various forms of distortion (for example, intermodulation distortion), and simple noise level. In some existing radio stations, the audio processing of the analog signal which is not included in this evaluation, if not judiciously applied, may tend to produce the more dynamic artifacts such as pumping, noise modulation, or dynamic spectral and stereo platform shifts. In the digital domain, source coding technologies inherently manipulate dynamic, spectral, and psychoacoustic components of the audio.

Performance goal: *Source coding manipulations of the audio should not cause artifacts that noticeably reduce the fidelity of the system throughout the service area.*

Due to their numerical nature, digital representations of audio signals have rigid upper limits in instantaneous level and do not begin to go into compression and distortion prior to clipping as would an analog representation. Thus, the headroom requirement for a digital system must be either more broad or more strict. A broader headroom requirement lowers the average program level closer to the noise floor. A stricter requirement would maintain less headroom by demanding that audio be more rigidly limited. Digital broadcasting is expected to engender new processor designs that will permit strict rather than broad headroom practices.

These differences in how headroom is handled remain an important factor to consider when comparing the dynamic range and noise characteristics of a digital technology with its analog counterpart. In digital systems, traditional noise measurement is not as meaningful as in analog. Expert listening will be required to evaluate noise effects in the digital and analog domains. Regarding dynamic range, it is important that the IBOC systems' perceptual audio coding algorithm can manage audio that is highly processed as well as audio that is not compressed in dynamic range.

Performance goal: *There should be sufficient apparent dynamic range to enable low level and dynamic content to reproduce with the same fidelity as aggressively processed audio.*

A.2.2 Durability of transmission systems

One aspect of analog systems is that as fidelity is compromised by channel impairments, listeners may choose to tolerate it because the still-audible program content is compelling or the impairment is expected to be transitory. In this regard, FM is a durable medium. Nonetheless, there is clearly a demand for more durable service.

A.2.2.1 Interference

A viable IBOC system should operate successfully within present AM and FM service areas. Thus, IBOC systems should be sufficiently robust to survive co- and adjacent channel interference in a service area at least as great as existing analog stations.

Performance goal: *Digital systems should reach a service area that, on a station-by-station basis, matches or exceeds the actual interference-limited service area of the analog hosts.*

A.2.2.2 Impairments

Analog FM is susceptible to a range of impairments including:

- Deep (“stoplight”) fades
- The distortion produced by multipath in mobile, fixed and portable situations
- Signal “flutter” produced by aircraft
- Reception that changes when people move in the vicinity of the radio
- Attenuation by buildings, and internal environmental noise
- Receiver overload induced intermodulation (in and out of official blanketing areas)

On the other hand, FM is relatively well protected from environmental noise.

The Analog AM broadcast service is susceptible to the following:

- Man-made and atmospheric noise
- Below ground-plane shielding (bridge effects, power lines and overhead signs)
- Receiver intermodulation
- Directional antenna pattern bandwidth distortions (phase and amplitude)

Digital technologies offer the opportunity to use advanced signal processing techniques, such as time diversity, to cover transient impairments. Fades and impairments that last too long or are too frequent will result in loss of audibility and ultimately failure.

Performance goal: *Digital technology will be considered to be better than analog against impairments if digital multipath and fade artifacts have the following characteristics:*

- *They are demonstrably less objectionable, less frequent in time and less prevalent in location than those of analog services;*
- *They maintain higher fidelity than analog for a preponderance of occurrences;*
- *They result in fewer total losses of intelligible audio than analog, and recovery from total loss is not significantly longer than analog in similar circumstances.*

A.2.3 Flexibility of transmission systems

FM broadcasting is a good example of a flexible broadcasting system that was able to benefit from enhancements over the decades. The addition of stereo audio to what was originally a monaural service is an example of one such enhancement. RBDS offers a very narrow data channel to transmit program-related information to listeners. Subcarrier technologies, including RBDS, permit broadcasters to use spectrum more efficiently to deliver services to niche segments of the population that otherwise could not take advantage of broadcast spectrum. FM receivers are designed for a range of user preferences and pocketbooks. Innovations in circuit component and design have permitted technological improvements in the fidelity, durability and flexibility of FM broadcasting. Transmitters are user-serviceable and continually becoming more reliable.

Performance goal: *A successful digital technology will:*

- *Reasonably protect the performance and flexibility of its analog host and adjacent channel stations;*
- *Provide a platform that can be improved in software, firmware and hardware in a manner that is compatible with its original technology;*
- *Give broadcasters tools to create features to enhance the listener experience and permit the medium to remain relevant and competitive in the coming decades.*

Appendix B – DAB Subcommittee Goals & Objectives



2500 Wilson Boulevard
Arlington, VA 22201-3834
(703) 907-7500
FAX (703) 907-7501

NATIONAL RADIO SYSTEMS COMMITTEE



1771 N Street, NW
Washington, DC 20036-2891
(202) 429-5339
FAX (202) 775-4981

5/14/98

DAB Subcommittee

Goals & Objectives

(as adopted by the Subcommittee on May 14, 1998)

Objectives

- (a) To study IBOC DAB systems and determine if they provide broadcasters and users with:
 - A digital signal with significantly greater quality and durability than available from the AM and FM analog systems that presently exist in the United States;
 - A digital service area that is at least equivalent to the host station's analog service area while simultaneously providing suitable protection in co-channel and adjacent channel situations;
 - A smooth transition from analog to digital services.
- (b) To provide broadcasters and receiver manufacturers with the information they need to make an informed decision on the future of digital audio broadcasting in the United States, and if appropriate to foster its implementation.

Goals

To meet its objectives, the Subcommittee will work towards achieving the following goals:

- (a) To develop a technical record and, where applicable, draw conclusions that will be useful to the NRSC in the evaluation of IBOC systems;
- (b) To provide a direct comparison between IBOC DAB and existing analog broadcasting systems, and between an IBOC signal and its host analog signal, over a wide variation of terrain and under adverse propagation conditions that could be expected to be found throughout the United States;
- (c) To fully assess the impact of the IBOC DAB signal upon the existing analog broadcast signals with which they must co-exist;
- (d) To develop a testing process and measurement criteria that will produce conclusive, believable and acceptable results, and be of a streamlined nature so as not to impede rapid development of this new technology;
- (e) To work closely with IBOC system proponents in the development of their laboratory and field test plans, which will be used to provide the basis for the comparisons mentioned in Goals (a) and (b);
- (f) To indirectly participate in the test process, by assisting in selection of (one or more) independent testing agencies, or by closely observing proponent-conducted tests, to insure that the testing as defined under Goal (e) is executed in a thorough, fair and impartial manner.

**Appendix E –
NRSC IBOC
System Evaluation Matrix**

NRSC IBOC System Evaluation Matrix – rev. 4

EVALUATION CRITERIA DESCRIPTIONS – IBOC RECEIVER RESULTS

Audio quality – the fundamental audio quality of the IBOC system, all channel impairments aside. This assessment is to be made with respect to the audio quality of the existing analog broadcasting service as represented by the NRSC broadcast chain audio.

Service area – the geographical area surrounding the transmit station which can be expected to receive a listenable (usable) radio signal. Applied separately to IBOC audio and IBOC auxiliary data capacity (i.e. degree of correlation needs to be established).

Durability – characterized by an IBOC system design’s ability to withstand interference from other radio signals (co-channel, 1st adjacent channel, and 2nd adjacent channel signals in particular) and to withstand the impairing effects of the RF channel. Applied separately to IBOC audio and IBOC auxiliary data capacity (i.e. degree of correlation needs to be established).

Acquisition performance – the characteristics of how a receiver “locks on” to a radio signal, including acquisition time (the elapsed time between tuning to a channel and when the audio on that channel is first heard), and audio quality following acquisition. Applies to both IBOC audio and IBOC auxiliary data capacity (in the latter case, performance metric is acceptable bit and/or frame error rate).

Auxiliary data capacity – characteristics of the data capacity supported by an IBOC system in excess of that needed to deliver the IBOC audio signal, including available throughput, nature of capacity (opportunistic versus continuously available), and transmission quality and durability through the channel (bit error rate and/or other relevant digital data transmission metrics as a function of impairments).

Behavior as signal degrades – how an IBOC system performs as its signal degrades, in particular, how abruptly the signal becomes unusable, and how the level of quality of the signal changes as the edge of coverage is approached. Note that, due to the complexities of RF signal propagation, “edge of coverage” performance may be experienced throughout a station’s service area and is not restricted simply to regions near or beyond the theoretical protected contour.

Stereo separation – the amount of stereo separation present in the IBOC audio signal, and how it varies as a function of channel and received signal conditions.

Flexibility – represents the potential of an IBOC system to be adapted by broadcasters and manufacturers to meet the needs of listeners and consumers, both present and future. [Primarily addressed in system description portion of submission; test results not expected to provide direct evidence of system flexibility.]

EVALUATION CRITERIA DESCRIPTIONS – ANALOG RECEIVER RESULTS

Host analog signal impact – changes in performance of a host analog signal (main channel audio and any subcarriers) as a result of the presence of the IBOC digital signal energy associated with that host.

Non-host analog signal impact – changes in the performance of a (desired) analog signal (main channel audio only) as a result of the presence of interfering IBOC signals. Interfering signals of interest include co-channel, 1st, and 2nd adjacent channel signals, individually and in combinations.

AM IBOC System Evaluation matrix – Lab tests – rev. 4

		R E C E I V E R U N D E R T E S T								
		I B O C							A N A L O G	
TEST	DESCRIPTION	AUDIO QUALITY	SERVICE AREA	DURA-BILITY	ACQ. PERFORM.	AUX. DATA CAPACITY	BEHAVIOR AS SIGNAL DEGRADES	STEREO SEP	HOST SIGNAL IMPACT	NON-HOST SIGNAL IMPACT
H	IBOC “analog-to-digital” compatibility performance									
1)	Co-channel interference									
2)	Single 1st-adjacent channel interference									
3)	Simultaneous upper and lower 1st-adjacent channel interference		✓	✓		✓	✓	✓		
4)	Single 2nd-adjacent channel interference									
3)	Simultaneous upper and lower 2nd-adjacent channel interference									
J	IBOC acquisition/re-acquisition performance									
1)	Short interruption, linear channel									
2)	Long interruption, linear channel									
3)	Short interruption, linear channel, AWGN				✓					
4)	Long interruption, linear channel, AWGN									
K	DAB quality									
1)	Subjective assessment report of unimpaired IBOC audio quality (linear channel) versus analog AM (and optionally, analog FM)	✓								
2)	“Long form” DAT through IBOC system									
L	IBOC “digital-to-host analog” compatibility performance									
1)	Host analog main channel audio performance versus presence or absence of IBOC digital signal energy								✓	
M	IBOC “host analog-to-digital” compatibility performance									
1)	Digital audio, data transmission performance versus percent modulation of analog host signal			✓		✓				

**Appendix F –
LDR submission – tests submitted**

Laboratory test data (FM):

NO.	ITEM	CHANNEL				INTERFERERS <i>D/U in dB</i>			DATA	GRAPHS	COMMENTS
		AWGN	LINEAR	NON-LINEAR	FADING	CO-CHAN	1ST-ADJ	2ND-ADJ			
B	IBOC system performance with AWGN										
3	Multipath fading, no interferers				RF				Appendix F.1, pg. 5 (in text)	Fig. F1-1 (pg. 3) – analog comparison also shown	<ul style="list-style-type: none"> • Subjectively evaluated (ACR vs. distance) • Noise not actually added; signal strength reduced instead
4	Multipath fading, 1st adj. channel interference				?		6 -1.5 -9			Fig. F1-2 (pg. 7) – analog comparison also shown	<ul style="list-style-type: none"> • No audio processing on IBOC audio • Analog benchmark data also obtained (only mobile receivers used for fading tests)
					RF		?		Appendix F.4, Table 7		
K	DAB quality										
1	Subjective assessment report of unimpaired IBOC audio quality versus analog FM		✓							Appendix F.3, Figures 1, 2	<ul style="list-style-type: none"> • PAC evaluated – bit rate unknown, presence or absence of IBOC modulation unknown • Audio materials listed in Appendix F.3, pg. 3, Table 1 • Analog benchmark data also obtained

Laboratory test data (FM, cont.):

NO.	ITEM	CHANNEL				INTERFERERS <i>D/U in dB</i>			DATA	GRAPHS	COMMENTS
		AWGN	LINEAR	NON-LINEAR	FADING	CO-CHAN	1ST-ADJ	2ND-ADJ			
L	IBOC “digital-to-host analog” compatibility perf. (cont.)										
1	Host analog main channel audio performance vs. presence or absence of IBOC (linear channel)		✓						(Results summarized on pgs. 4-5 of Appendix G)	Appendix G, Figs. 1a, 1b (pg. 10), Figs. 2a, 2b (pgs. 11, 12)	<ul style="list-style-type: none"> • 5 analog receivers used • Subj. evaluated
			✓						Appendix F.4, Table 3 (1st Table 3, pg. 7)	Appendix F.4, Fig. 1 (pg. 6)	<ul style="list-style-type: none"> • 4 analog receivers used • Subj. evaluated vs signal strength – IBOC carriers always on
2	Host analog main channel audio performance vs. presence or absence of IBOC (fading channel)				US UF RF TO				(Results summarized on pgs. 4-5 of Appendix G)	Appendix G, Figs. 1a, 1b (pg. 10), Figs. 2a, 2b (pgs. 11, 12)	<ul style="list-style-type: none"> • 5 analog receivers used • Subj. evaluated
*	Host analog main channel audio performance with fading				RF				Appendix F.4, Table 3 (2nd Table 3, pg. 9)	Appendix F.4, Fig. 2 (pg. 8)	<ul style="list-style-type: none"> • 2 receivers used (both automotive) • Subj. evaluated – IBOC carriers always on
*	Host analog main channel audio performance with 1st adj. interference		✓				+31 +18.5 +6 -1.5 -9		Appendix F.4, Table 4 (pg. 10)		<ul style="list-style-type: none"> • Subj. evaluated – IBOC carriers always on
					RF			Appendix F.4, Table 5 (pg. 11)			
*	Host analog main channel audio performance vs. output SNR (AWQP) ??		✓		RF				Appendix F.4, Table 6 (pg. 12)		<ul style="list-style-type: none"> • 6 receivers • Subj. evaluated – IBOC carriers always on

* indicates test not specified by NRSC’s test guidelines.

Field test data (FM):

NO.	ITEM	CHANNEL				INTERFERERS <i>D/U in dB</i>			DATA	GRAPHS	COMMENTS
		AWGN	LINEAR	NON-LINEAR	FADING	CO-CHAN	1ST-ADJ	2ND-ADJ			
B	Strong signal with low interference										
1	Low multipath				✓				("Audio field test sampler" audio file – cut 9, described in Appendix K)		<ul style="list-style-type: none"> • Host stations: WBJB-FM, WPST-FM • Multi-streaming PAC at 128 kbps demonstrated
2	Strong multipath				✓						
C	Single interferer										
1	Single 1st-adjacent channel interferer (at FCC limit)						✓		("Audio field test sampler" audio file – cut 9, described in Appendix K)		<ul style="list-style-type: none"> • Host stations: WBJB-FM, WPST-FM • Multi-streaming PAC at 128 kbps demonstrated
3	Single 1st-adjacent channel interferer (above FCC limit)						✓				

Laboratory test data (AM):

NO.	ITEM	CHANNEL				INTERFERERS <i>D/U in dB</i>			DATA	GRAPHS	COMMENTS
		AWGN	LINEAR	NON-LINEAR	FADING	CO-CHAN	1ST-ADJ	2ND-ADJ			
B	IBOC system performance with AWGN										
1	Linear channel, no interferers		✓						Table J-1, pg. 6		<ul style="list-style-type: none"> • FER vs. S/N (FER given by stream) • Analog audio restricted to ± 4.5 kHz (all tests)
C	IBOC system performance with special impairments										
2	Weak signal		✓						Table J-2, pg. 7		FER vs. signal level (FER given by stream)
D	IBOC “digital-to-digital” compatibility performance										
1	Co-channel		✓			+28 +27 +26 +25 +23 +21			Table J-3, pg. 8		<ul style="list-style-type: none"> • FER vs. co-channel D/U (FER given by stream) • Both desired and undesired are IBOC carriers
3	Dual 1st-adj.		✓				(2) +22 +21 +20 +19 +18 +17		Table J-5, pg. 11		<ul style="list-style-type: none"> • 1st adj. interferers are IBOC with ± 4.5 kHz analog • Upper and lower 1st adj. at same level • FER vs. dual 1st-adj. channel D/U (FER given by stream)

Laboratory test data (AM, cont.):

NO.	ITEM	CHANNEL				INTERFERERS <i>D/U in dB</i>			DATA	GRAPHS	COMMENTS
		AWGN	LINEAR	NON-LINEAR	FADING	CO-CHAN	1ST-ADJ	2ND-ADJ			
H	IBOC “analog-to-digital” compatibility performance										
3	Dual 1st-adj.		✓				(2) +7 +6 +5 +4 +3 +2		Table J-4, pg. 10		<ul style="list-style-type: none"> • 1st adj. interferers are analog (not IBOC) and band limited to ± 4.5 kHz • FER vs. dual 1st-adj. channel D/U (FER given by stream)
D/H	IBOC compatibility performance										
*			✓				+23 +21 +20 +17 +16 +15 +8 +6 +3	+20 +10 0	Table J-6, pg. 13		<ul style="list-style-type: none"> • 1st adj. interferer is analog (not IBOC), and band limited to ± 4.5 kHz ; 2nd adj. interferer is IBOC • Various combinations of 1st, 2nd adj. chnl. D/U tested • FER vs. D/U (FER given by stream)

* indicates test not specified by NRSC’s test guidelines.

Field test data (AM):

NO.	ITEM	CHANNEL				INTERFERERS <i>D/U in dB</i>			DATA	GRAPHS	COMMENTS
		AWGN	LINEAR	NON-LINEAR	FADING	CO-CHAN	1ST-ADJ	2ND-ADJ			

(no data submitted)

**Appendix G –
LDR comments on this evaluation report**

**COMMENTS OF LUCENT DIGITAL RADIO
CONCERNING NRSC DAB SUBCOMMITTEE EVALUATION
OF ITS FM AND AM IBOC SYSTEM TESTS**

Lucent Digital Radio (“LDR”), a subsidiary of Lucent Technologies, Inc., is the developer of digital radio systems that will enable AM and FM broadcasters to deliver new and better services to the American public.

LDR’s systems utilize patented Multi-Streaming PAC™ technology to achieve clear digital reception even in the crowded signal conditions that will exist during the transition to digital. PAC™ also is being used for digital audio broadcasts delivered by satellite (“SDARS”). This commonality ensures the highest reception quality of both satellite and terrestrial digital radio, and will result in economies of scale in the receiver marketplace that will lower costs, accelerate the digital broadcast revolution, and directly benefit consumers.

LDR’s in-band, on-channel (IBOC) systems for AM and FM each consist of two related designs. One, hybrid IBOC, permits broadcasters to initiate digital service using their current spectrum while continuing to transmit today’s analog signals to their listeners with no noticeable impairment. The prototypes of these hybrid IBOC systems are the subjects of the attached Report by the National Radio Systems Committee (“NRSC”) Digital Audio Broadcasting (DAB) Subcommittee. LDR’s other system is all-digital. It is being designed to be compatible with LDR’s hybrid IBOC system, and will provide a seamless transition from hybrid to all-digital modes so that consumers will attain the benefits of increased capacity and expanded data opportunities at the completion of the transition from analog to digital.

LDR believes and continues to advocate that system evaluations require testing that is conducted by third parties under strict identical circumstances. Using such a process, a system can be compared rapidly and efficiently both to existing analog and to competing digital systems. For all parties involved, such testing will save much expense and time, and provide a technically valid basis for evaluating all aspects of the proponent systems.

Although LDR's arguments for third party controlled testing were not adopted by the NRSC DAB Subcommittee for the initial tests addressed in this report, at its January, 2000, meeting the NRSC DAB Subcommittee voted to go forward to a standardization process for an IBOC standard if the first test results are sufficient. The test results show the great potential of IBOC, and we expect this future process to proceed by consensus and to include laboratory, field, and subjective comparative testing at an independent laboratory, such as the Advanced Television Testing Center (ATTC), or similar independent facility. We are confident that such testing will confirm our very favorable results.

In the time period provided for the recently completed phase of testing, LDR did the testing that it could accomplish within the context of its overall developmental effort and its need to simultaneously address issues raised by the Federal Communications Commission in its Notice of Proposed Rulemaking (which was released on November 1, 1999). LDR focused its testing upon those elements that would best reveal the quality and robustness of its hybrid IBOC system, and submitted substantial data to the Subcommittee. This included a significant amount of subjective test data, which shows the LDR IBOC system to have superior audio performance to analog FM. Subjective

tests are likely to more precisely indicate the preferences of customers, and when combined with objective measurements can be a good aid in system design.

In its report, the Subcommittee concludes that the tests indicate the reasonable probability of substantial improvement for broadcast listening when compared to the performance of analog AM and FM. LDR wishes to add that the substantial data capacity of its systems also will be of great benefit to the broadcasters' audiences. The many test systems that we have deployed in field testing gives us great confidence that our systems based upon Multi-Streaming PAC™ will be superior to today's analog systems. Our tests demonstrate the clear superiority of LDR's digital system, both for audio and with regard to the new services facilitated by the system's data capabilities.

Consumers can benefit from the increased audio quality and new data services made possible by LDR's digital system without the Federal Communications Commission (FCC) having to allocate a single kilohertz of new spectrum. This fact has the potential of shaving years off the time that otherwise would be needed to implement a new-band terrestrial digital radio broadcasting.

LDR continues to innovate its systems and to conduct additional testing. In April, 2000, over-the-air testing and demonstrations are being conducted in Las Vegas, Nevada, in conjunction with the National Association of Broadcasters (NAB) convention at which this report is being issued.

We believe in private industry initiatives, but also recognize the necessary role of the FCC as spectrum manager and regulator. We will continue to participate actively in the Subcommittee's work and to keep the FCC fully informed.

To the greatest extent feasible, industry itself should evaluate digital broadcast system options and ascertain the service features that will best meet the future needs of broadcasters, manufacturers, and the public. We are confident that the LDR hybrid IBOC and all-digital systems are the superior systems upon which to base new digital broadcast standards for the 21st Century. The attached report is the first step in that direction.

NRSC-R54

NRSC Document Improvement Proposal

If in the review or use of this document a potential change appears needed for safety, health or technical reasons, please fill in the appropriate information below and email, mail or fax to:

National Radio Systems Committee
c/o Consumer Electronics Association
Technology & Standards Department
1919 S. Eads St.
Arlington, VA 22202
FAX: 703-907-4190
Email: standards@ce.org

DOCUMENT NO.	DOCUMENT TITLE:	
SUBMITTER'S NAME:	TEL:	
COMPANY:	FAX:	
	EMAIL:	
ADDRESS:		
URGENCY OF CHANGE: _____ Immediate _____ At next revision		
PROBLEM AREA (ATTACH ADDITIONAL SHEETS IF NECESSARY): a. Clause Number and/or Drawing: b. Recommended Changes: c. Reason/Rationale for Recommendation:		
ADDITIONAL REMARKS:		
SIGNATURE:		DATE:
FOR NRSC USE ONLY		
Date forwarded to NAB S&T:	_____	
Responsible Committee:	_____	
Co-chairmen:	_____	
Date forwarded to co-chairmen:	_____	



CEA[®]
Consumer Electronics Association

