

NATIONAL RADIO SYSTEMS COMMITTEE

THIS IS AN
OUTDATED
VERSION

IN-BAND/ON-CHANNEL
DIGITAL RADIO BROADCASTING
STANDARD
NRSC-5
April, 2005



NAB: 1771 N Street NW,
Washington DC 20036
Tel: 202-429-5346 Fax: 202-775-4981



CEA: 2500 Wilson Boulevard,
Arlington VA 22201
Tel: 703-907-7660 Fax: 703-907-8113

Co-sponsored by the Consumer Electronics Association and the National Association of Broadcasters
<http://www.nrscstandards.org>

NOTICE

NRSC Standards, Bulletins and other technical publications are designed to serve the public interest through eliminating misunderstandings between manufacturers and purchasers, facilitating interchangeability and improvement of products, and assisting the purchaser in selecting and obtaining with minimum delay the proper product for his particular need. Existence of such Standards, Bulletins and other technical publications shall not in any respect preclude any member or nonmember of the Consumer Electronics Association (CEA) or the National Association of Broadcasters (NAB) from manufacturing or selling products not conforming to such Standards, Bulletins or other technical publications, nor shall the existence of such Standards, Bulletins and other technical publications preclude their voluntary use by those other than CEA or NAB members, whether the standard is to be used either domestically or internationally.

Standards, Bulletins and other technical publications are adopted by the NRSC in accordance with the NRSC patent policy. By such action, CEA and NAB do not assume any liability to any patent owner, nor do they assume any obligation whatever to parties adopting the Standard, Bulletin or other technical publication.

Note: The user's attention is called to the possibility that compliance with this standard may require use of an invention covered by patent rights.

By publication of this standard, no position is taken with respect to the validity of this claim or of any patent rights in connection therewith. The patent holder has, however, filed a statement of willingness to grant a license under these rights on reasonable and nondiscriminatory terms and conditions to applicants desiring to obtain such a license. Details may be obtained from the publisher.

This NRSC Standard is considered to have International Standardization implication, but the International Electrotechnical Commission activity has not progressed to the point where a valid comparison between the NRSC Standard and the IEC document can be made.

This Standard does not purport to address all safety problems associated with its use or all applicable regulatory requirements. It is the responsibility of the user of this Standard to establish appropriate safety and health practices and to determine the applicability of regulatory limitations before its use.

Published by

©CONSUMER ELECTRONICS ASSOCIATION 2005
Technology & Standards Department
2500 Wilson Boulevard
Arlington, VA 22201

©NATIONAL ASSOCIATION OF BROADCASTERS 2005
Science and Technology Department
1771 N Street, NW
Washington, DC 20036

All rights reserved
Printed in U.S.A.

PLEASE!

DON'T VIOLATE
THE
LAW!

This document is copyrighted by CEA and NAB and may not be reproduced without permission.

This document is distributed free of charge via the NRSC website at:

<http://www.nrscstandards.org>

This blank page is for formatting purposes only.

FOREWORD

This standard was developed by the National Radio Systems Committee's Digital Audio Broadcasting Subcommittee. At the time of adoption, the NRSC was chaired by Charles Morgan of Susquehanna Broadcasting, the DAB Subcommittee was co-chaired by Michael Bergman of Kenwood and Milford Smith of Greater Media, and the IBOC Standards Development Working Group was co-chaired by Paul Feinberg of Sony Electronics Inc. and Dr. H. Donald Messer of the International Broadcasting Bureau.

The NRSC is jointly sponsored by the Consumer Electronics Association and the National Association of Broadcasters. It serves as an industry-wide standards-setting body for technical aspects of terrestrial over-the-air radio broadcasting systems in the United States.

This blank page is for formatting purposes only.

CONTENTS

1	SCOPE	1
2	REFERENCES	1
2.1	Normative References	1
2.2	Normative Reference Acquisition	2
2.3	Informative References.....	2
2.4	Informative Reference Acquisition	2
2.5	Definitions	2
2.6	Symbols and Abbreviations	4
2.7	Compliance Notation.....	5
3	SYSTEM OVERVIEW	6
3.1	RF/transmission Subsystem	7
3.2	Transport and Service Multiplex Subsystem	7
3.3	Audio and Data Input Subsystems	8
3.3.1	Audio Inputs.....	8
3.3.2	Data Inputs.....	8
	Program Service Data Inputs.....	8
	3.3.2.2 Other Data Inputs.....	9
4	RF/TRANSMISSION SYSTEM CHARACTERISTICS.....	10
4.1	AM RF/transmission System Characteristics.....	10
4.1.1	Transmission Characteristics.....	11
4.1.2	Layer 1 Interface.....	12
4.1.3	Logical Channels	12
4.1.4	Channel Coding	12
	4.1.4.1 Scrambling	12
	4.1.4.2 Channel Encoding.....	12
	4.1.4.3 Interleaving.....	12
4.1.5	System Control Processing	13
4.1.6	Subcarrier Mapping and Modulation.....	14
4.1.7	Transmission	14
4.2	FM RF System Characteristics	18
4.2.1	Transmission Characteristics.....	19
4.2.2	Layer 1 Interface.....	20
4.2.3	Logical Channels	21
4.2.4	Channel Coding	21
	4.2.4.1 Scrambling	21
	4.2.4.2 Channel Encoding.....	21
	4.2.4.3 Interleaving.....	21
4.2.5	System Control Processing	22
4.2.6	Subcarrier Mapping and Modulation.....	23
4.2.7	Transmission	23
5	TRANSPORT AND SERVICE MULTIPLEX CHARACTERISTICS	27
5.1	Core Services Overview	27

NRSC-5

5.1.1	Main Program Service (MPS)	27
5.1.2	Station Information Service (SIS)	27
5.2	Supplemental Services Overview	27
5.2.1	Supplemental Program Service (SPS)	27
5.3	Advanced Data Services	28
5.4	Core Services Description	28
5.4.1	Main Program Service (MPS)	28
5.4.1.1	MPS Audio	28
5.4.1.2	MPS Data Interface and Transport	29
5.4.2	Station Information Service (SIS)	30
5.4.2.1	SIS Interface	30
5.4.2.2	SIS Transport	31
5.5	Channel Multiplex	31
5.5.1	Interface to RF/transmission subsystem	31
5.5.2	Configuration Administrator	31
6	AUDIO ENCODER CHARACTERISTICS	32
6.1	Coding rates	32
6.2	Opportunistic Data	33

IN-BAND/ON-CHANNEL DIGITAL RADIO BROADCASTING STANDARD

1 SCOPE

This standard sets forth the requirements for a system for broadcasting digital audio and ancillary digital data signals over AM broadcast channels spaced 10 kHz apart that may contain analog amplitude modulated signals, and over FM broadcast channels spaced 200 kHz apart that may contain analog frequency modulated signals.

2 REFERENCES

2.1 Normative References

The following normative references are incorporated by reference herein. At the time of publication the edition indicated was valid. All standards are subject to revision, and parties to agreements based on this standard are encouraged to investigate the possibility of applying the most recent editions of this standard and/or the references listed below. In case of discrepancy normative references shall prevail.

For the purposes of compliance with this standard, the use of the term "HD Radio" in the normative references shall be interpreted as the generic term "IBOC" for the NRSC-5 compliant system and shall not be construed as a requirement to adhere to undisclosed private specifications that are required to license the HD Radio name from its owner.

Note that information relating to the iBiquity Advanced Application Service (AAS) in the normative reference documents is considered non-normative with respect to the NRSC-5 standard at this time.

1. Doc. No. SY_IDD_1011s rev. E, HD Radio™ Air Interface Design Description - Layer 1 FM, iBiquity Digital Corporation, 3/22/05
2. Doc. No. SY_IDD_1012s rev. E, HD Radio™ Air Interface Design Description – Layer 1 AM, iBiquity Digital Corporation, 3/22/05
3. Doc. No. SY_IDD_1014s rev. F, HD Radio™ Air Interface Design Description – Layer 2 Channel Multiplex Protocol, iBiquity Digital Corporation, 2/7/05
4. Doc. No. SY_IDD_1017s rev. E, HD Radio™ Air Interface Design Description – Audio Transport, iBiquity Digital Corporation, 3/31/05
5. Doc. No. SY_IDD_1020s rev. E, HD Radio™ Air Interface Design Description – Station Information Service Protocol, iBiquity Digital Corporation, 2/18/05
6. Doc. No. SY_SSS_1026s rev. D, HD Radio™ FM Transmission System Specifications, iBiquity Digital Corporation, 2/18/05
7. Doc. No. SY_IDD_1028s rev. C, HD Radio™ Air Interface Design Description – Main Program Service Data, iBiquity Digital Corporation, 3/31/05
8. Doc. No. SY_SSS_1082s rev. D, HD Radio™ AM Transmission System Specifications, iBiquity Digital Corporation, 2/24/05
9. Doc. No. SY_IDD_1085s rev. C, HD Radio™ Air Interface Design Description – Program Service Data Transport, iBiquity Digital Corporation, 2/7/05

2.2 Normative Reference Acquisition

iBiquity Digital Corporation reference documents:

National Radio Systems Committee (co-sponsored by the Consumer Electronics Association and the National Association of Broadcasters)

CEA: 2500 Wilson Boulevard, Arlington VA 22201; Tel: 703-907-7625; Fax: 703-907-7601

NAB: 1771 N Street NW, Washington DC 20036; Tel: 202-429-5346; Fax: 202-775-4981

<http://www.nrcstandards.org>

2.3 Informative References

The following references contain information that may be useful to those implementing this standard. At the time of publication the edition indicated was valid. All standards are subject to revision, and parties to agreements based on this standard are encouraged to investigate the possibility of applying the most recent editions of the standards listed below.

(None in this version)

2.4 Informative Reference Acquisition

(Not applicable)

2.5 Definitions

In this standard the practice of the Institute of Electrical and Electronics Engineers (IEEE) as outlined in the Institute's published standards is used for definitions of terms. Definitions of terms used in this standard that are not covered by IEEE practice, or for which industry practice differs from IEEE practice, are as follows:

Advanced data services

Advanced data services are any data services consisting of either text, audio, video, or other data carried on the IBOC transport other than SIS, MPSD, or SPSP.

All digital waveform

A transmitted waveform for modes composed entirely of digitally modulated subcarriers without an analog signal.

Channel encoding

The process used to add error protection to each of the logical channels to improve the reliability of the transmitted information.

Code rate

Defines the increase in overhead on a coded channel resulting from channel encoding. It is the ratio of information bits to the total number of bits after coding.

Convolutional encoding

A form of forward-error-correction channel encoding that inserts coding bits into a continuous stream of information bits to form a predictable structure. Unlike a block encoder, a convolutional encoder has memory; its output is a function of current and previous inputs.

Diversity delay

Imposition of a fixed time delay in one of two channels carrying the same information to defeat non-stationary channel impairments such as fading and impulsive noise.

Extended hybrid waveform

A transmitted waveform for modes composed of the analog FM signal plus digitally modulated primary main subcarriers and some or all primary extended subcarriers. This waveform will

NRSC-5

normally be used during an initial transitional phase preceding conversion to the all digital waveform.

Frequency partition	(For FM IBOC) a group of OFDM subcarriers containing data subcarriers and a reference subcarrier.
Hybrid waveform	A transmitted waveform for modes composed of the analog - modulated signal, plus digitally modulated primary main subcarriers. This waveform will normally be used during an initial transitional phase preceding conversion to the all digital waveform.
Interleaver partition	A logical subdivision of the overall interleaver matrix.
Interleaving	A reordering of the message bits to distribute them in time (over different OFDM symbols) and frequency (over different OFDM subcarriers) to mitigate the effects of signal fading and interference.
Interleaving process	A series of manipulations performed on one or more coded transfer frames (vectors) to reorder their bits into one or more interleaver matrices whose contents are destined for a particular portion of the transmitted spectrum.
Logical channel	A signal path that conducts transfer frames from Layer 2 through Layer 1 with a specified grade of service.
Main Program Service (MPS)	The audio programming and program service data that a radio station broadcasts over its main channel for reception by the general public.
Main Program Service Data (MPSD)	One of two general classes of information sent through the MPS (the other being Main Program Service Audio). Main Program Service Data is Program Service Data (defined below) that is associated with the Main Program Service.
OFDM subcarrier	A narrowband PSK or QAM-modulated carrier within the allocated channel, which, taken together with all OFDM subcarriers, constitute the frequency domain representation of one OFDM symbol.
OFDM symbol	Time domain pulse of duration T_s , representing all the active subcarriers and containing all the data in one row from the interleaver and system control data sequence matrices.
Program Service Data (PSD)	Data that is transmitted along with the program audio and that is intended to describe or complement the audio program heard by the listener (e.g., song title, artist, etc.)
Reference subcarrier	Dedicated OFDM subcarrier modulated with the SCCH data. There are up to 61 reference subcarriers depending on the mode (for FM) and up to 4 for AM.
Service mode	A specific configuration of operating parameters specifying throughput, performance level, and selected logical channels.

NRSC-5

Station Information Service (SIS)	The Station Information Services provides the necessary radio station control and identification information, such as station call sign identification, time and location reference information.
Supplemental Program Service (SPS)	The Supplemental Program Service provides for the option of multiplexing additional programs with the MPS. The SPS includes Supplemental Program Service Audio (SPSA) and may also include Supplemental Program Service Data (SPSD).
Supplemental Program Service Data (SPSD)	One of two general classes of information sent through the SPS (the other being Supplemental Program Service Audio). Supplemental Program Service Data is Program Service Data (defined above) that is associated with the Supplemental Program Service.
System control channel (SCCH)	A channel consisting of control information from the configuration administrator and status information from Layer 1.
System control data sequence	A sequence of bits destined for each reference subcarrier representing the various system control components relayed between Layer 1 and Layer 2.
System protocol stack	The ordered protocols associated with data processing in the transmitter and receiver.
Transfer frame	An ordered, one-dimensional collection of data bits of specified length originating in Layer 2, grouped for processing through a logical channel.
Transfer frame multiplexer	A device that combines two or more transfer frames into a single vector.

2.6 Symbols and Abbreviations

Symbols and abbreviations used in this standard are as follows:

ADS	Advanced Data Services
AM	Amplitude Modulation
BPSK	Binary Phase Shift Keying
FCC	Federal Communications Commission
FM	Frequency Modulation
GPS	Global Positioning System
IBOC	In-Band/On-Channel
ID	Identification
IP	Interleaving Processes
L1	Layer 1
MF	Medium Frequency
MPA	Main Program Service Audio
MPS	Main Program Service
N/A	Not Applicable
OFDM	Orthogonal Frequency Division Multiplexing
P3IS	P3 Interleaver Select
PAD	Program Associated Data

PCM	Pulse Code Modulation
PDU	Protocol Data Unit
PIDS	Primary IBOC Data Service Logical Channel
PM	Primary Main
PSD	Program Service Data
PX	Primary Extended
QAM	Quadrature Amplitude Modulation
QPSK	Quadrature Phase Shift Keying
RF	Radio Frequency
SB	Secondary Broadband
SCCH	System Control Channel
SIDS	Secondary IBOC Data Service Logical Channel
SIS	Station Information Service
SM	Secondary Main
SP	Secondary Protected
SPS	Supplemental Program Service
SX	Secondary Extended
URL	Uniform Resource Locator
VHF	Very High Frequency

2.7 Compliance Notation

As used in this document, “shall” or “will” denotes a mandatory provision of the standard. “Should” denotes a provision that is recommended but not mandatory. “May” denotes a feature whose absence does not preclude compliance, and that may or may not be present at the option of the implementer.

3 SYSTEM OVERVIEW

The In-Band/On-Channel (IBOC) digital radio broadcasting system specified in this standard is designed to permit a smooth evolution from current analog radio broadcasting to fully digital radio broadcasting. This system delivers digital audio and data services to mobile, portable, and fixed receivers from terrestrial transmitters on existing Amplitude Modulation (AM) and Frequency Modulation (FM) radio broadcast channels. Broadcasters may continue to transmit AM and FM analog signals simultaneously with the IBOC digital signals, allowing themselves and their listeners to convert from analog to digital radio while maintaining their current frequency allocations.

The system accepts as input compressed digital audio and utilizes baseband signal processing techniques such as interleaving and forward error correction to increase the robustness of the signal in the transmission channel. This allows a high quality audio signal plus ancillary data to be transmitted using power levels and band segments selected to minimize interference to existing analog signals.

Figure 1 illustrates the three major subsystems of the IBOC digital radio system specified by NRSC-5 and how they relate to one another.¹ The major subsystems are:

- RF/transmission subsystem
- Transport and service multiplex subsystem
- Audio and data input subsystems

¹ This system, operating in modes MP1 (FM band) and MA1 (AM band) underwent an extensive evaluation by the NRSC. The NRSC has not tested or evaluated any modes other than these. These operating modes are described in reference [1] and reference [2] for the FM and AM bands, respectively. The NRSC IBOC evaluation reports, entitled "Evaluation of the iBiquity Digital Corporation IBOC System, Part 1 – FM IBOC," National Radio Systems Committee DAB Subcommittee, November 29, 2001, and "Evaluation of the iBiquity Digital Corporation IBOC System, Part 2 – AM IBOC," National Radio Systems Committee DAB Subcommittee, April 6, 2002, are available on the NRSC web site at www.nrscstandards.org.

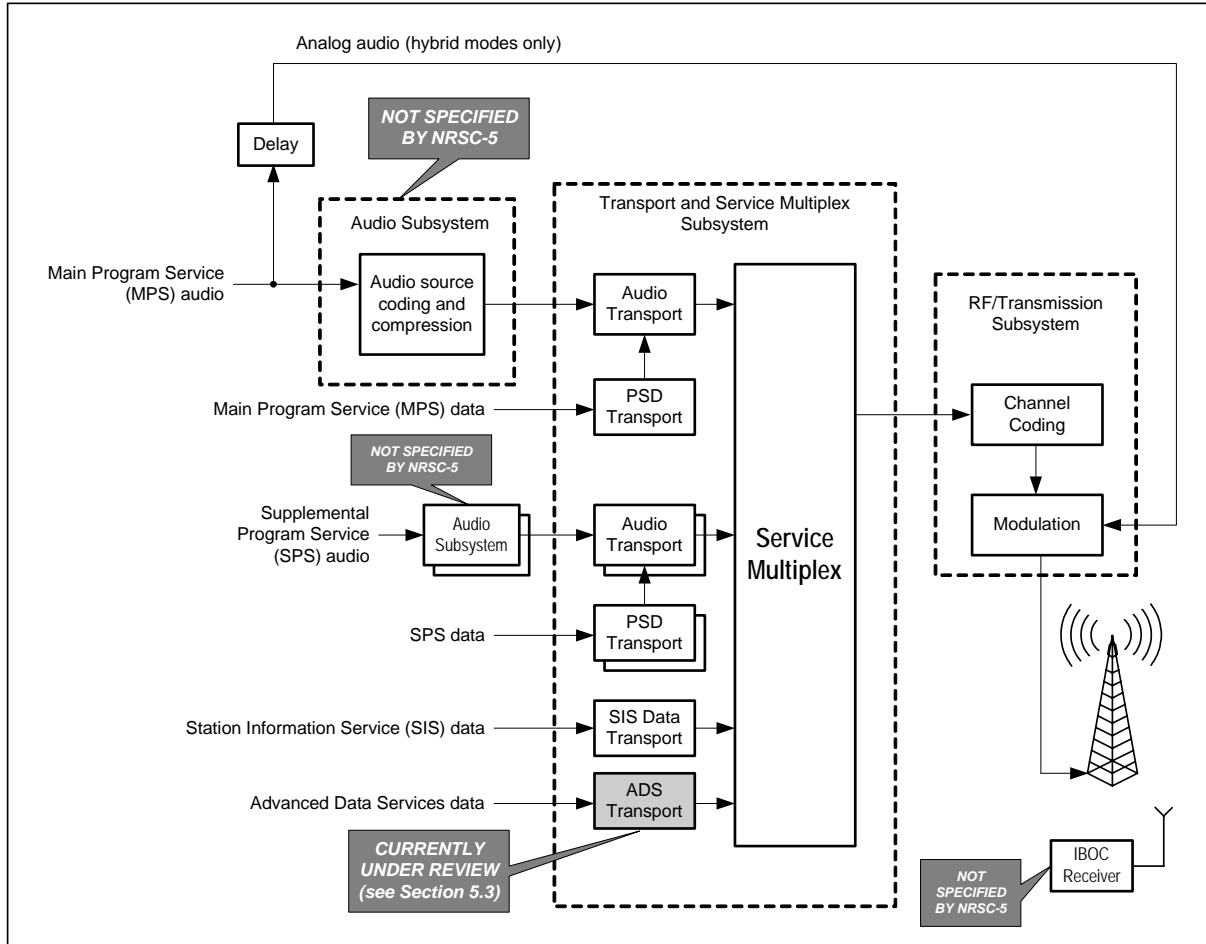

Figure 1: Overview of IBOC digital radio system

3.1 RF/transmission Subsystem

The RF/transmission subsystem shall comply with the requirements in references [1] and [6] for FM and references [2] and [8] for AM. This subsystem takes the multiplexed bit stream and applies coding and interleaving that can be used by the receiver to reconstruct the transmitted data, even when the received signal does not exactly match the transmitted signal due to impairments in the channel. The multiplexed and coded bit stream is modulated onto orthogonal frequency division multiplexed (OFDM) subcarriers and up-converted to the AM or FM band. A description of the RF/transmission subsystem is given in Section 4; a detailed specification is given in references [1] and [6] (FM band) and references [2] and [8] (AM band).

3.2 Transport and Service Multiplex Subsystem

The transport and service multiplex subsystem shall comply with the requirements in references [3], [4], [5], and [9]. This subsystem feeds the information to be transmitted to the RF/transmission subsystem. It takes the audio and data information that it receives, organizes it into packets, and multiplexes the packets into a single data stream. Each packet is uniquely identified as an audio or data packet. Certain data packets (*i.e.*, those containing program service data, which includes song title, artist, etc.) are added to the stream of packets carrying their associated audio information before they are fed into the multiplexer.

The transport stream is modeled loosely on the ISO 7498-1 standard. A description of the transport and service multiplex subsystem is given in Section 5; a detailed specification is given in references [3], [4], [5], and [9].

3.3 Audio and Data Input Subsystems

3.3.1 Audio Inputs

Source coding and compression of the main program service (MPS) and supplemental program service (SPS) audio must be performed before the audio information is fed into the audio transport subsystems. Each audio service (main program service and each individual supplemental program service) has its own source coding, compression and transport subsystem. NRSC-5 does not include specifications for audio source coding and compression. Suitable audio source coding and compression systems will use appropriate technologies (e.g., perceptual audio coding) to reduce the bit rate required for description of audio signals.

In hybrid modes the analog MPS audio is also modulated directly onto the RF carrier for reception by conventional analog receivers. The MPS analog audio does not pass through the audio transport subsystem, and is delayed so that it will arrive at the receiver close enough in time to the digital signal.² This will enable seamless switching from digital to analog reception when the received signal quality is not sufficient for digital audio reception or when digital packets in the MPS PDU are corrupted. This “blend” capability is also used for fast channel changes, allowing the receiver to demodulate and play out the analog stream first and then blend to the digital audio stream.

MPS audio is discussed further in Section 5, and some of the necessary characteristics for audio source coding are described in Section 6.

3.3.2 Data Inputs

There are two types of data inputs to the IBOC digital radio system. The first type is program service data, which includes descriptive information associated with the transmitted audio programming such as song title and artist. The second type is non-program service data, which is referred to generally as other data inputs.

3.3.2.1 Program Service Data Inputs

Program service data inputs shall comply with the requirements in references [7] and [5]. There are two types of program service data. The first is program service data (PSD), which is transmitted along with the program audio and is intended to describe or complement the audio program heard by the radio listener. The PSD fields include song title, artist, album, genre, comment, commercial and reference identifiers. A description of PSD is given in Section 5; a detailed specification is given in reference [7].

The second type of program service data is station information service (SIS) data. SIS data provides more general information about the station's program, as well as some technical information that is useful for non-program related applications. The SIS fields include station identification number (based in part on the FCC facility identification number), station call letters, station name, station location, two fields dedicated to station time, a field that permits the broadcaster to send an arbitrary text message, and two reserved fields. A description of SIS data is given in Section 5; a detailed specification is given in reference [5].

² This is referred to as “diversity delay,” T_{dd} , and is specified in references [1] and [2].

3.3.2.2 Other Data Inputs

Advanced data services (ADS) will be incorporated into this Standard and more fully detailed in additional reference documents at a later date. Advanced data services provide broadcasters with the ability to transmit information that may be unrelated to MPS, SIS or SPS. These services can carry any form and content that can be expressed as a data file or a data stream, including audio services. Examples of such services include (i) visual effects associated with MPS, SIS, or SPS services; (ii) multimedia presentations of stock, news, weather, and entertainment programming including audio, text and images; (iii) broadcast updates to in-vehicle systems; (iv) local storage of content for time shifting and later replay; (v) targeted advertising; and (vi) traffic updates and information for use with navigation systems. These are discussed further in Section 5.

4 RF/TRANSMISSION SYSTEM CHARACTERISTICS

4.1 AM RF/transmission System Characteristics

This section specifies the RF portion of the NRSC-5 IBOC digital radio standard for AM band implementations. Figure 2 illustrates how the RF/transmission portion of the standard relates to the other parts. It is an overview of the entire AM band implementation of the NRSC-5 IBOC digital radio standard.

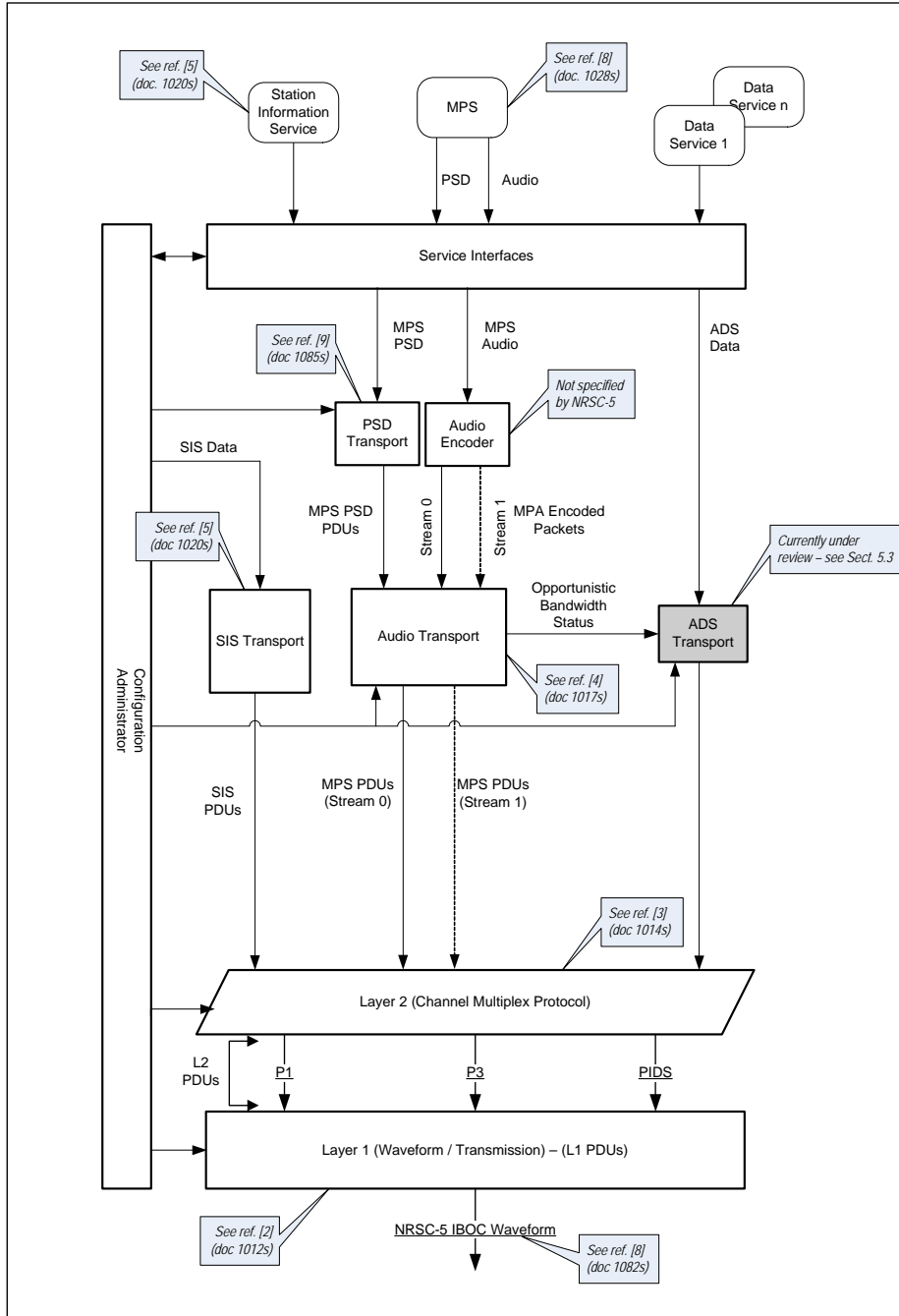

Figure 2: AM band implementation of NRSC-5 IBOC digital radio standard

4.1.1 Transmission Characteristics

This section includes a high-level description of each Layer 1 functional block and the associated signal flow. Figure 3 is a top level block diagram of the RF/transmission subsystem illustrating the order of processing therein. Figure 4 is a functional block diagram of Layer 1 processing. Audio and data are passed from the higher protocol layers to the physical layer, the modem, through the Layer 2 – Layer 1 interface.

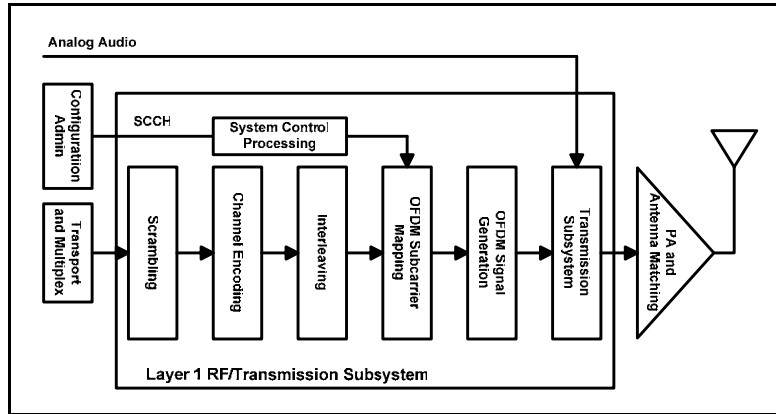

Figure 3: RF/transmission subsystem block diagram

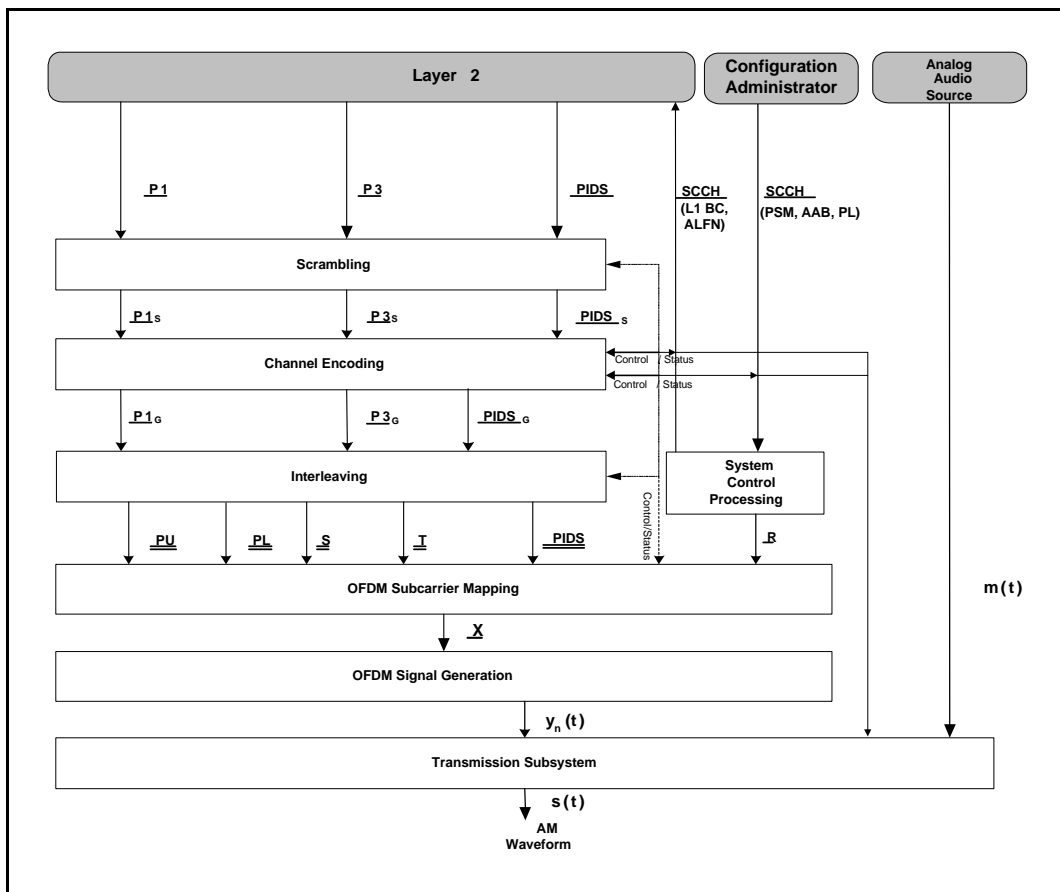

Figure 4: AM air interface Layer 1 functional block diagram with details of data flow illustrated

4.1.2 Layer 1 Interface

The layer 1 interface illustrates the access points between the channel multiplex and layer 1 of the system protocol stack. Data enters layer 1 as discrete transfer frames, with unique size and rate determined by the service mode, as specified in references [1] and [2]. Transfer frames that carry information from the channel multiplex are referred to as L1 PDUs.

4.1.3 Logical Channels

The concept of logical channels and their function is central to the transport and transmission of data through the IBOC system. A logical channel is a signal path that conducts Layer 1 PDUs through Layer 1 with a specified grade of service. Logical channels are specified in reference [2]. In Figure 4 the logical channels are denoted by symbols such as P1, PIDS, etc. The underscore indicates that the data in the logical channel is formatted as a vector.

4.1.4 Channel Coding

Channel coding comprises the functions of scrambling, channel encoding, and interleaving shown in Figure 3 and specified in references [1] and [2].

4.1.4.1 Scrambling

This function (specified in references [1] and [2]) randomizes the digital data in each logical channel to “whiten” and mitigate signal periodicities when the waveform is demodulated in a conventional analog AM demodulator. The bits in each logical channel are scrambled to randomize the time-domain data and aid in receiver synchronization. The inputs to the scramblers are the active logical channels from Layer 2, as selected by the service mode. The outputs of the scramblers are transfer frames of scrambled bits for each of the active logical channels. The scrambler generates a pseudorandom code which is modulo 2 summed with the input data vectors. The code generator is a linear feedback shift register.

4.1.4.2 Channel Encoding

Channel encoding improves system performance by increasing the robustness of the signal in the presence of channel impairments. The channel encoding process is characterized by punctured convolutional encoding.

Punctured convolutional encoding is applied to each logical channel in the RF/transmission subsystem for forward error correction. Several different encoding polynomials and puncture matrices are used. Different logical channels have different code rates. The specification of the forward error correction coding used for each logical channel and each service mode is contained in reference [2].

4.1.4.3 Interleaving

Interleaving is also applied to the logical channels in the RF/transmission subsystem. The interleaving process provides both time and frequency diversity. The manner in which diversity delay (time) is applied to these logical channels is specified in reference [2] for each service mode. The delay provides time diversity to the affected logical channels. If applied, the value of the diversity delay is a fixed value.

Interleaving comprises three parallel interleaving processes (IPs): P1, P3, and PIDS (see Figure 5). An IP contains one or more interleavers, and, in some cases, a diversity delay buffer. The service mode determines which inputs and IPs are active at any given time. The IPs also generate subframes, creating the diversity delay path which results in main and backup streams. Bit mapping of the interleaver output assigns the encoded bits to unique locations in the interleaver output. The interleaver outputs are matrices. The interleaving processes for each service mode are specified in Section 10 of reference [2].

NRSC-5

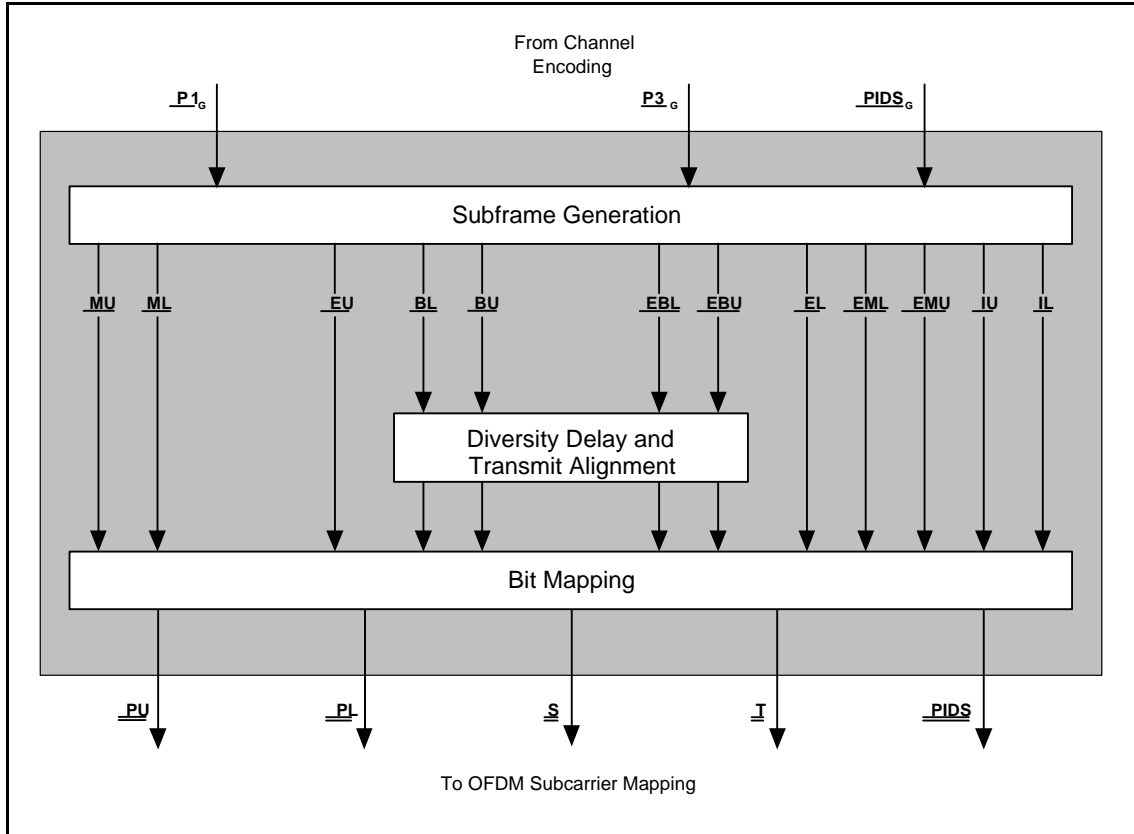

Figure 5: Interleaving conceptual block diagram

4.1.5 System Control Processing

As shown in Figure 3, the system control channel (SCCH) bypasses the channel coding. Under the direction of the system configuration settings, system control processing assembles and differentially encodes a sequence of bits (system control data sequence) destined for each reference subcarrier, as shown in Figure 6. There are 2 reference subcarriers at specific carrier offsets in the OFDM spectrum. This processing is specified in Section 11 of reference [2].

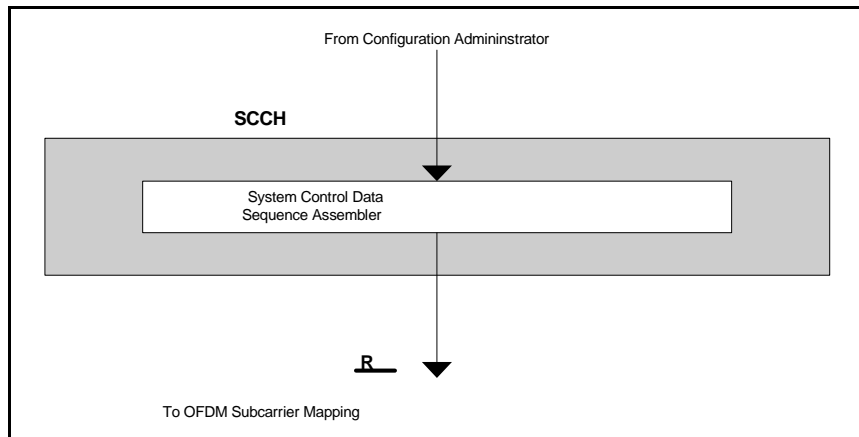

Figure 6: System control processing conceptual diagram

4.1.6 Subcarrier Mapping and Modulation

OFDM subcarrier mapping assigns interleaver partitions to frequency partitions. For each active interleaver matrix, OFDM subcarrier mapping assigns a row of bits from each interleaver to its respective frequency carrier and constellation value in the complex output vector \underline{X} . In addition, system control data sequence bits from a row of \underline{R} are mapped to the active reference subcarrier locations in \underline{X} . The service mode dictates which interleaver matrices and which elements of \underline{R} are active. Figure 7 shows the inputs, output, and component functions of OFDM subcarrier mapping.

The inputs to OFDM subcarrier mapping for each symbol are a row of bits from each active interleaver matrix and a row of bits from \underline{R} , the matrix of system control data sequences. The output from OFDM subcarrier mapping for each OFDM symbol is a single complex vector, \underline{X} , of length 163.

The interleaver matrices carrying the user audio and data (\underline{PU} , \underline{PL} , \underline{S} , \underline{T} , \underline{PIDS}) are mapped to scaled quadrature phase shift keying (QPSK), 16-QAM, or 64-QAM constellation points and to specific subcarriers. The R matrix is mapped to binary phase shift keying (BPSK) constellation points and the reference subcarriers. These phasors are then scaled in amplitude and then mapped to their assigned OFDM subcarriers. This process results in a vector, \underline{X} , of phasors which are output to the OFDM signal generation function. This processing is specified in Section 12 of reference [2].

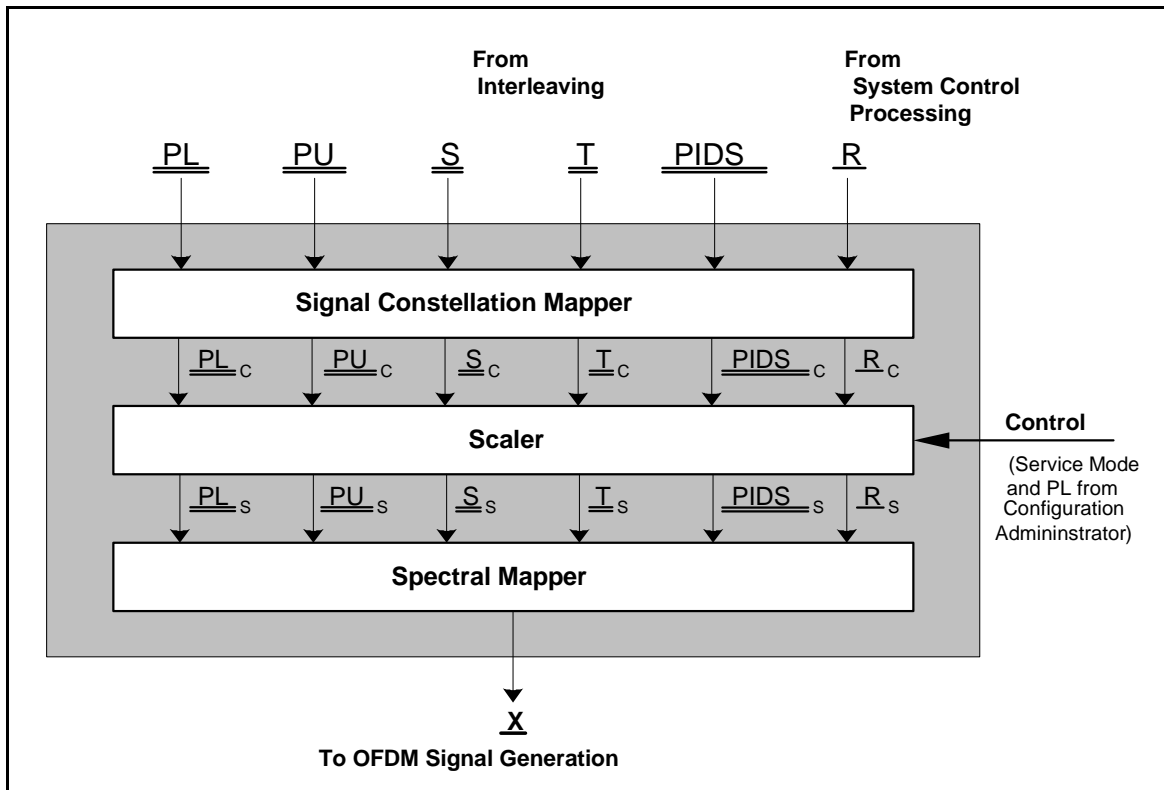

Figure 7: OFDM subcarrier mapping conceptual block diagram

4.1.7 Transmission

OFDM signal generation receives complex, frequency-domain OFDM symbols from OFDM subcarrier mapping, and outputs time-domain pulses representing the digital portion of the AM IBOC signal.

The input to OFDM signal generation for the n^{th} symbol is a complex vector \underline{X}_n of length L , representing the complex constellation values for each OFDM subcarrier in OFDM symbol n . For notational

convenience, the output of OFDM subcarrier mapping described above did not use the subscript n . Rather, it referred to the vector \underline{X} as representing a single OFDM symbol. In this section, the subscript is appended to \underline{X} because of the significance of n to OFDM signal generation. The OFDM symbol is transformed to the time domain by a discrete Fourier transform and shaped to create one time domain symbol, $y_n(t)$. The output of OFDM signal generation is a complex, baseband, time-domain pulse $y_n(t)$, representing the digital portion of the AM IBOC signal for OFDM symbol n .

The $y_n(t)$ symbols are concatenated to form a continuous time domain waveform. This OFDM waveform is combined (summed) with the amplitude modulated (AM) waveform $a_n(t)$ (in the hybrid mode) to create $z_n(t)$. This waveform is upconverted to create the complete IBOC RF waveform for transmission. This is illustrated in Figure 8. The waveform is then spectrally mapped and frequency partitioned across the set of OFDM subcarriers. Reference [8] details the key transmission specifications for the AM IBOC RF waveform including carrier frequency and channel spacing, synchronization tolerances, analog host performance, spectral emission limits, digital sideband levels, analog modulation level, phase noise, error vector magnitude, gain flatness, amplitude and phase symmetry, and group delay flatness.

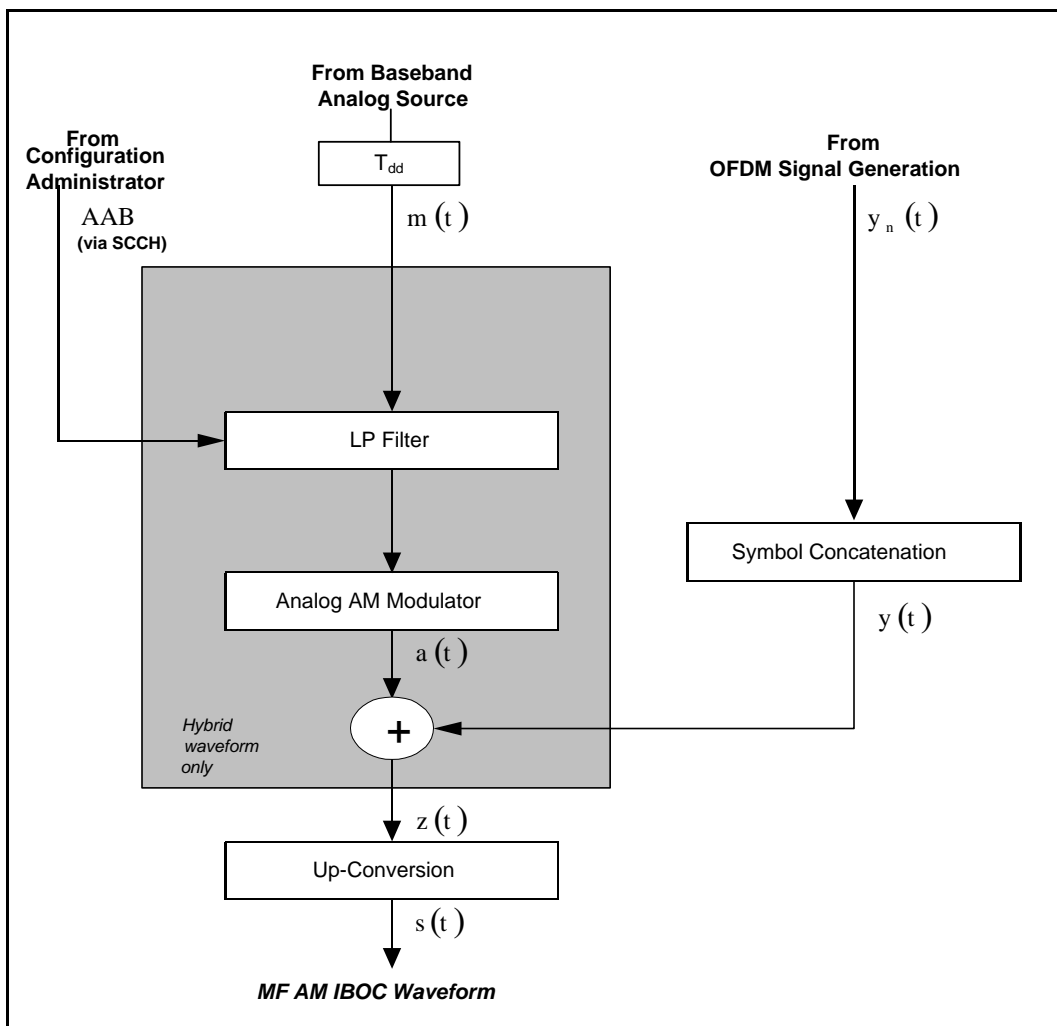

Figure 8: Hybrid/extended hybrid transmission subsystem functional block diagram

NRSC-5

For hybrid transmissions utilizing 5 kHz analog bandwidth, noise and spuriously generated signals from all sources, including phase noise and intermodulation products, shall conform to the limits as described in Section 4.5.1 of reference [8] and shown in Figure 9.³

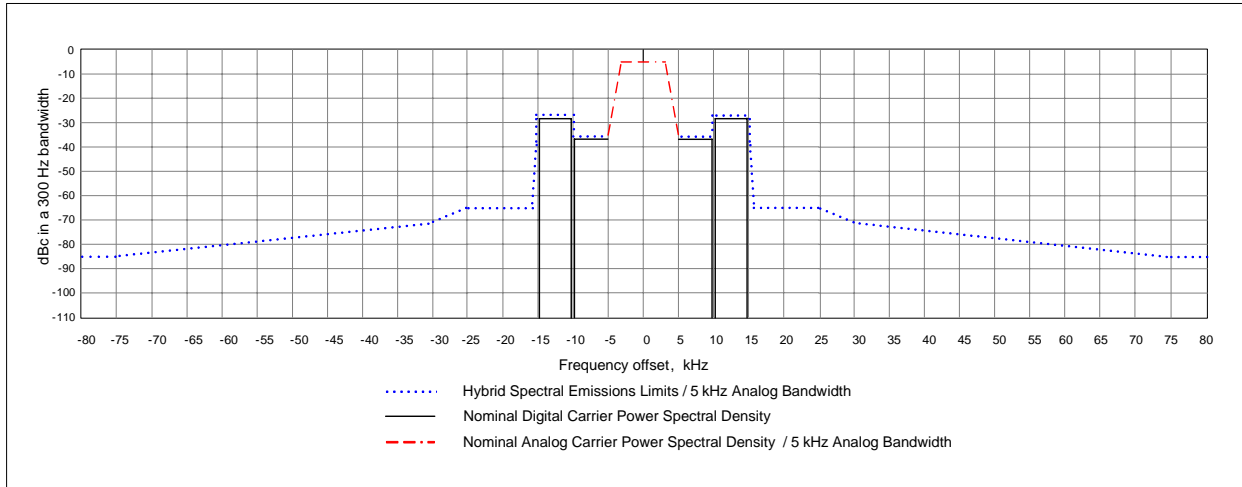

Figure 9. NRSC-5 AM hybrid waveform spectral emissions limits for 5 kHz analog bandwidth

For hybrid transmissions utilizing 8 kHz analog bandwidth, noise and spuriously generated signals from all sources, including phase noise and intermodulation products, shall conform to the limits as described in Section 4.5.2 of reference [8] and shown in Figure 10.

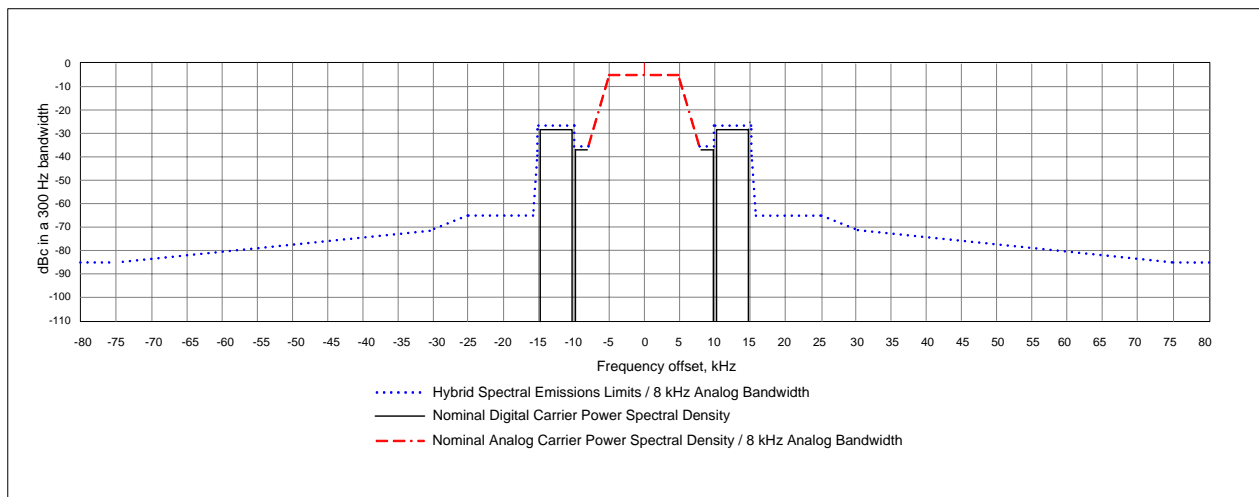

Figure 10. NRSC-5 AM hybrid waveform spectral emissions limits for 8 kHz analog bandwidth

³ The requirements for noise and spurious emission limits illustrated in Figures 9-11 reflect acceptable performance criteria. In certain circumstances, additional measures (filtering, active emissions suppression, etc.) may be needed to reduce the spectral emissions below the limits given in this subsection in order to reduce mutual interference between broadcast stations.

NRSC-5

For all-digital transmissions, noise and spuriously generated signals from all sources, including phase noise and intermodulation products, shall conform to the limits as described in Section 4.5.2 of reference [8] and shown in Figure 11.

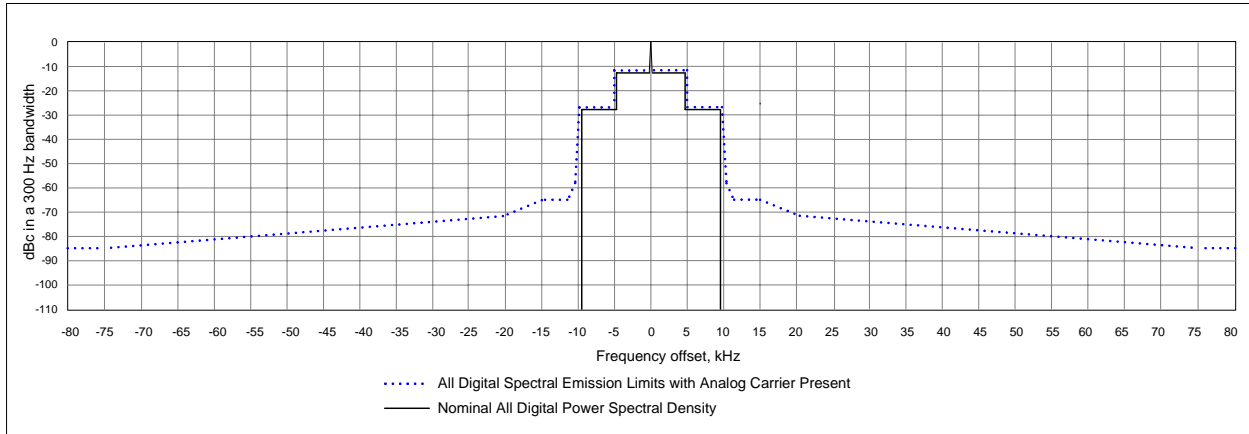

Figure 11. NRSC-5 AM all-digital waveform spectral emissions limits

There are several issues of time alignment that the transmission system must address. For transmit facilities so equipped, every L1 frame transmitted must be properly aligned with GPS time. Also, the various logical channels must be properly aligned with each other and in some service modes some channels are purposely delayed by a fixed amount to accommodate diversity combining at the receiver. Layer 1 provides for the time alignment of the transfer frames received from the channel multiplex. The higher protocol layers provide alignment of the contents of the transfer frames.

4.2 FM RF System Characteristics

This section specifies the RF portion of the NRSC-5 IBOC digital radio standard for FM band implementations. Figure 12 illustrates how the standard is partitioned according to protocol layer and is annotated with the referenced documents that specify the associated detailed requirements. It is an overview of the entire FM band implementation of the NRSC-5 IBOC digital radio standard.

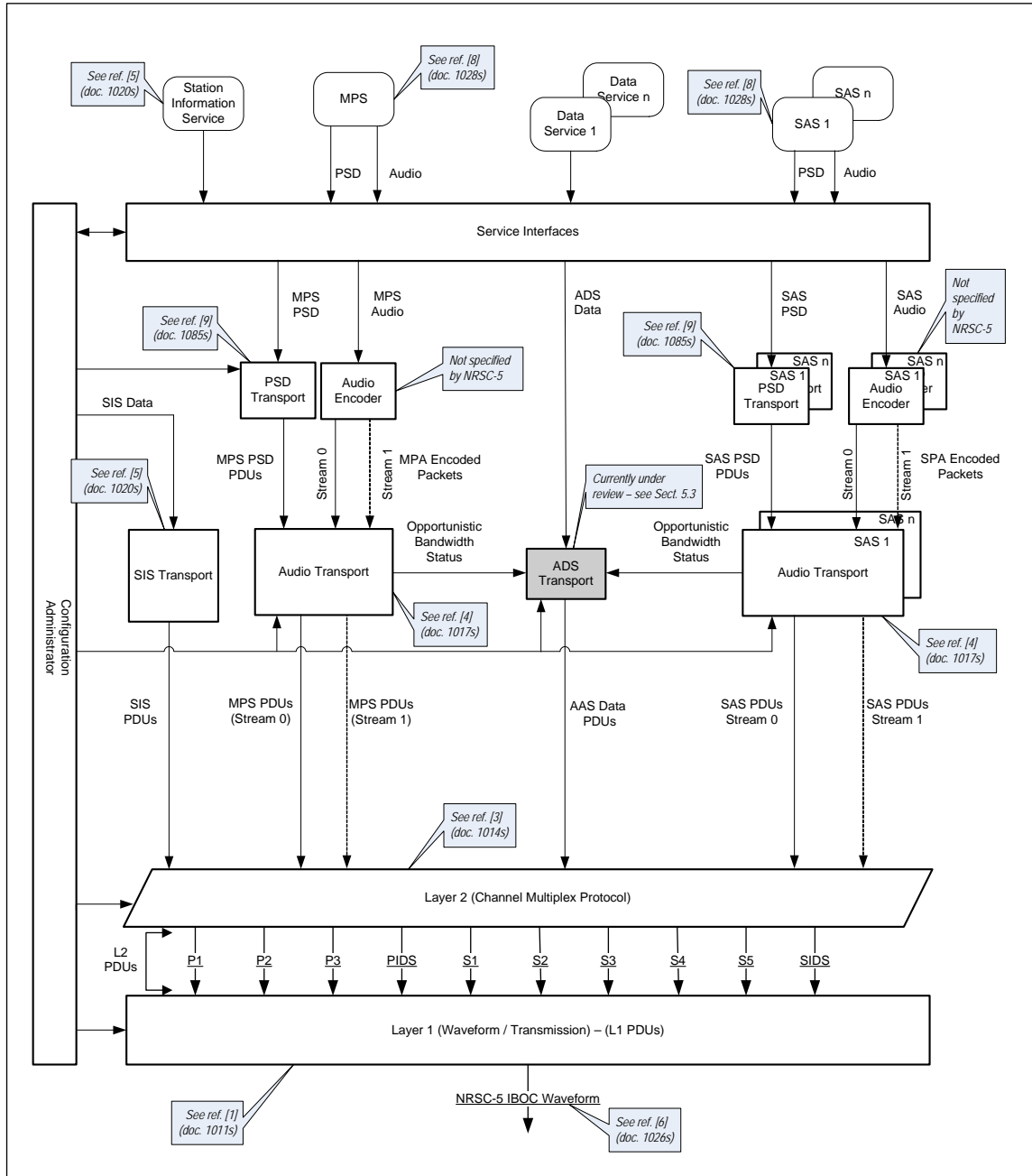

Figure 12: FM band implementation of NRSC-5 IBOC digital radio standard

4.2.1 Transmission Characteristics

This section includes a high-level description of each Layer 1 functional block and the associated signal flow. Figure 13 is a top level block diagram of the RF/transmission subsystem illustrating the order of processing therein. Figure 14 is a functional block diagram of Layer 1 processing. Audio and data are passed from the higher protocol layers to the physical layer, the modem, through the Layer 2 - Layer 1 interface.

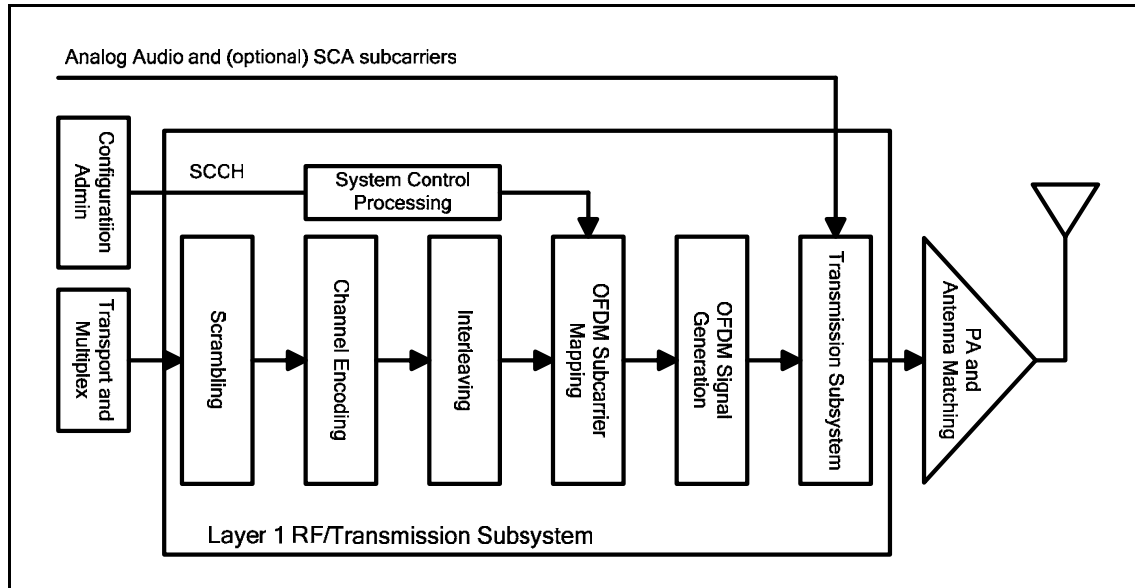

Figure 13: RF/transmission subsystem block diagram

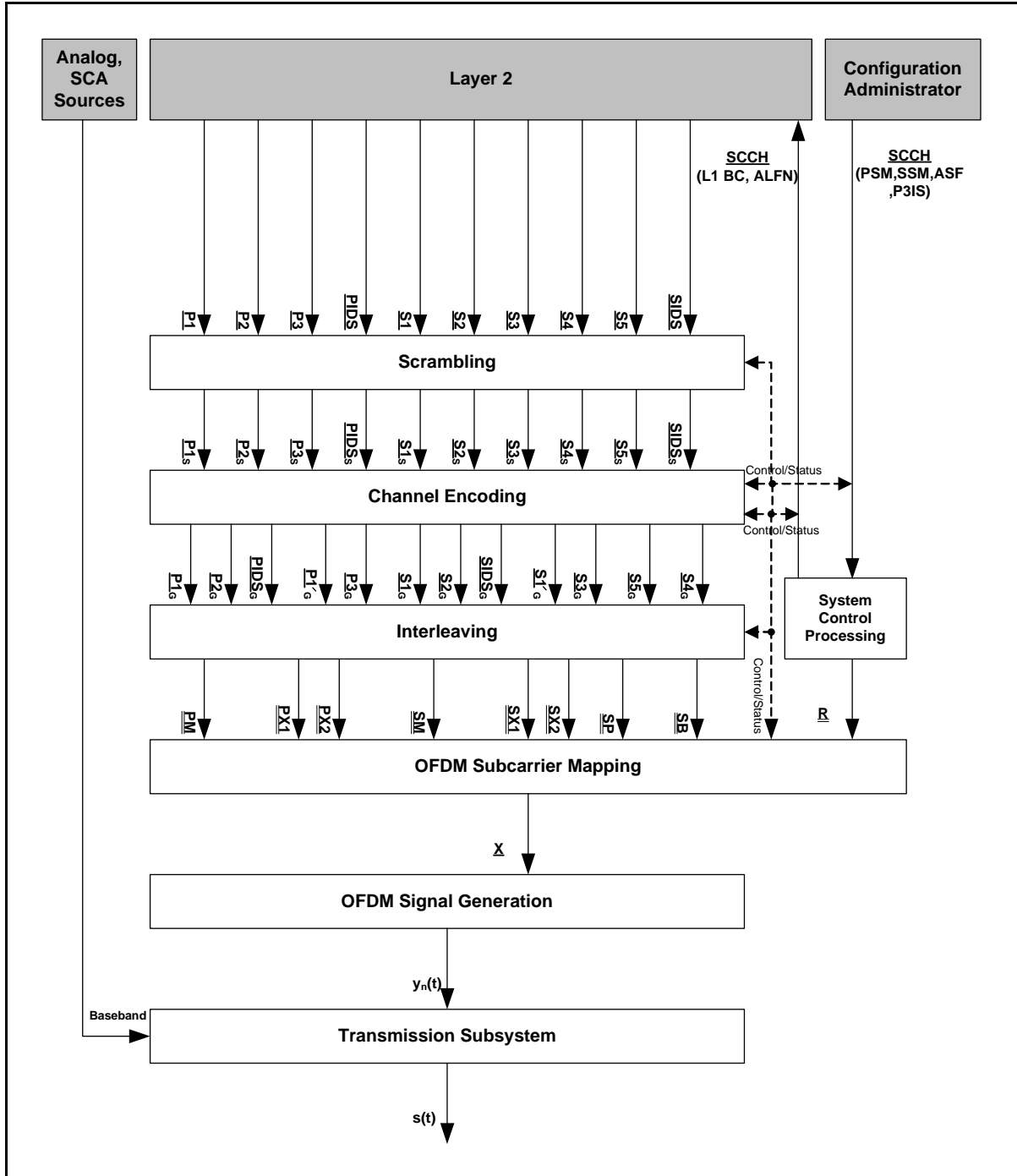

Figure 14: FM air interface Layer 1 functional block diagram with details of data flow illustrated

4.2.2 Layer 1 Interface

The L1 interface illustrates the access points between the channel multiplex and Layer 1 of the system protocol stack. Each channel enters Layer 1 in discrete transfer frames, with unique size and rate determined by the service mode. Transfer frames that carry information from the channel multiplex are referred to as L1 PDUs.

4.2.3 Logical Channels

The concept of logical channels and their function is central to the transport and transmission of data through the IBOC system. A logical channel is a signal path that conducts Layer 1 PDUs through Layer 1 with a specified grade of service. Logical channels are specified in reference [1]. In Figure 14 the logical channels are denoted by symbols such as P1, PIDS, S1, etc. The underscore indicates that the data in the logical channel is formatted as a vector.

4.2.4 Channel Coding

Channel coding (specified in references [1] and [2]) comprises the functions of scrambling, channel encoding, and interleaving shown in Figure 13.

4.2.4.1 Scrambling

This function randomizes the digital data in each logical channel to “whiten” and mitigate signal periodicities when the waveform is demodulated in a conventional analog FM demodulator. The bits in each logical channel are scrambled to randomize the time-domain data and aid in receiver synchronization. The inputs to the scramblers are the active logical channels from Layer 2, as selected by the service mode. The outputs of the scramblers are transfer frames of scrambled bits for each of the active logical channels. The scrambler generates a pseudorandom code which is modulo 2 summed with the input data vectors. The code generator is a linear feedback shift register.

4.2.4.2 Channel Encoding

Channel encoding improves system performance by increasing the robustness of the signal in the presence of channel impairments. The channel encoding process is characterized by two main operations: time delay (for diversity delay and transmit alignment) and convolutional encoding.

Depending on the service mode, logical channels P1 and S1 may be split into two channels and delayed as they enter the channel encoding process. The manner in which diversity delay is applied to these logical channels is specified in reference [1] for each service mode. The delay provides time diversity to the affected logical channels. If applied, the value of the diversity delay is a fixed value.

Punctured convolutional encoding is applied to each logical channel in the RF/transmission subsystem for forward error correction. Several different encoding polynomials and puncture matrices are used. Different logical channels have different code rates. The specification of the forward error correction coding used for each logical channel and each service mode is contained in reference [1].

4.2.4.3 Interleaving

Interleaving is also applied to the logical channels in the RF/transmission subsystem. Interleaving comprises six parallel interleaving processes (IPs): PM, PX, SM, SX, SP, and SB (see Figure 15). An IP contains one or more interleavers, and, in some cases, a transfer frame multiplexer. The service mode determines which inputs and IPs are active at any given time. In addition, for those service modes where the P3 logical channel is active, the P3 Interleaver Select (P3IS) control bit obtained from the system configuration administrator determines whether a long or short interleaver is employed. The universe of inputs for interleaving are the channel-encoded transfer frames from the primary logical channels P1 through P3 and PIDS, and the secondary logical channels S1 through S5 and SIDS. The interleaver outputs are matrices. The interleaving processes for each service mode are specified in Section 10 of reference [1].

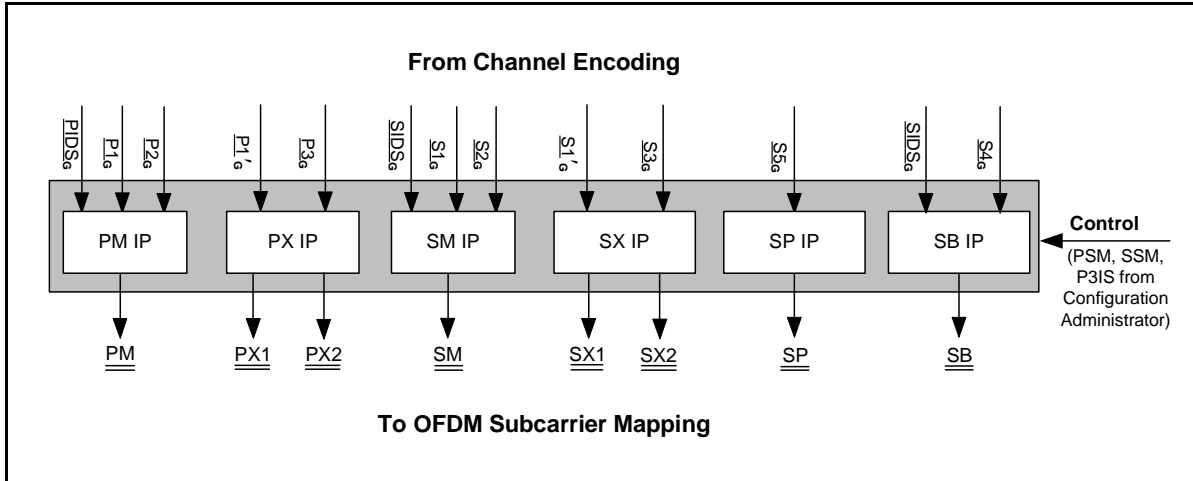

Figure 15: Interleaving conceptual block diagram

4.2.5 System Control Processing

As shown in Figure 14, the system control channel (SCCH) bypasses the channel coding. Under the direction of the system configuration settings, system control processing assembles and differentially encodes a sequence of bits (system control data sequence) destined for each reference subcarrier, as shown in Figure 16. There are up to 61 reference subcarriers, numbered 0 ... 60, distributed throughout the OFDM spectrum. The number of reference subcarriers broadcast in a given waveform depends on the service mode; however, system control processing always outputs all 61 system control data sequences, regardless of service mode. This processing is specified in Section 11 of reference [1].

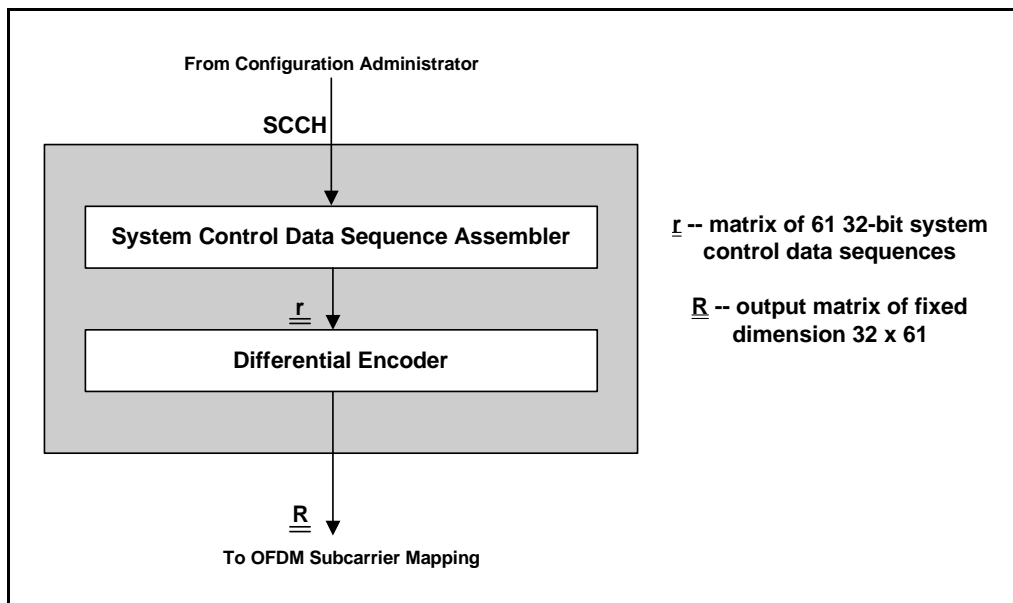

Figure 16: System control processing conceptual diagram

4.2.6 Subcarrier Mapping and Modulation

OFDM subcarrier mapping assigns interleaver partitions to frequency partitions. For each active interleaver matrix, OFDM subcarrier mapping assigns a row of bits from each interleaver partition to its respective frequency partition in the complex output vector \underline{X} . In addition, system control data sequence bits from a row of \underline{R} are mapped to the active reference subcarrier locations in \underline{X} . The service mode dictates which interleaver matrices and which elements of \underline{R} are active. Figure 17 shows the inputs, output, and component functions of OFDM subcarrier mapping.

The inputs to OFDM subcarrier mapping for each symbol are a row of bits from each active interleaver matrix and a row of bits from \underline{R} , the matrix of system control data sequences. The output from OFDM subcarrier mapping for each OFDM symbol is a single complex vector, \underline{X} , of length 1093.

The interleaver matrices carrying the user audio and data (\underline{PM} , $\underline{PX1}$, ... \underline{SB}) are mapped to quadrature phase shift keying (QPSK) constellation points and to specific subcarriers. The R matrix is mapped to binary phase shift keying (BPSK) constellation points and the reference subcarriers. These phasors are then scaled in amplitude and then mapped to their assigned OFDM subcarriers. This process results in a vector, \underline{X} , of phasors which are output to the OFDM signal generation function. This processing is specified in Section 12 of reference [1].

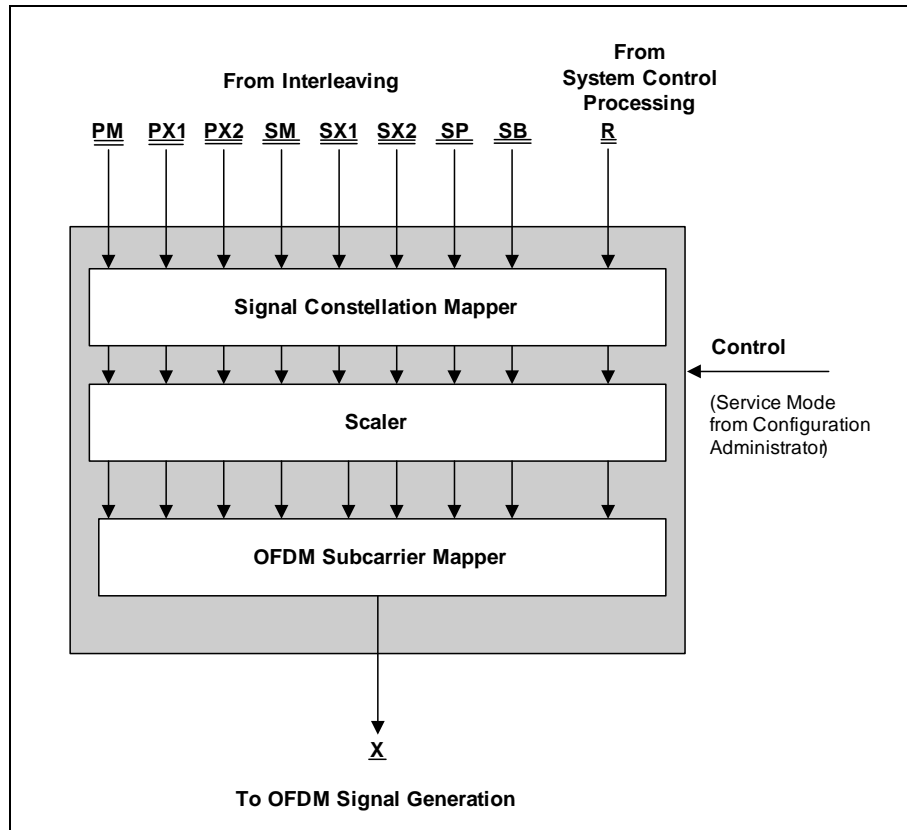

Figure 17: OFDM subcarrier mapping conceptual block diagram

4.2.7 Transmission

OFDM signal generation receives complex, frequency-domain OFDM symbols from OFDM subcarrier mapping, and outputs time-domain pulses representing the digital portion of the FM IBOC signal.

The input to OFDM signal generation for the n^{th} symbol is a complex vector \underline{X}_n of length L , representing the complex constellation values for each OFDM subcarrier in OFDM symbol n . For notational convenience, the output of OFDM subcarrier mapping described above did not use the subscript n .

Rather, it referred to the vector \underline{X} as representing a single OFDM symbol. In this section, the subscript is appended to \underline{X} because of the significance of n to OFDM signal generation. The OFDM symbol is transformed to the time domain by a discrete Fourier transform and shaped to create one time domain symbol, $y_n(t)$. The output of OFDM signal generation is a complex, baseband, time-domain pulse $y_n(t)$, representing the digital portion of the FM IBOC signal for OFDM symbol n .

The $y_n(t)$ symbols are concatenated to form a continuous time domain waveform. This waveform is upconverted and combined with the analog modulated audio (in the hybrid and extended hybrid modes) to create the complete IBOC RF waveform for transmission. This is illustrated in Figure 18. The waveform is then spectrally mapped and frequency partitioned across the set of OFDM subcarriers. Reference [6] details the key transmission specifications for the FM IBOC RF waveform including carrier frequency and channel spacing, synchronization tolerances, spectral emission limits, digital sideband levels, phase noise, error vector magnitude, gain flatness, and group delay flatness.

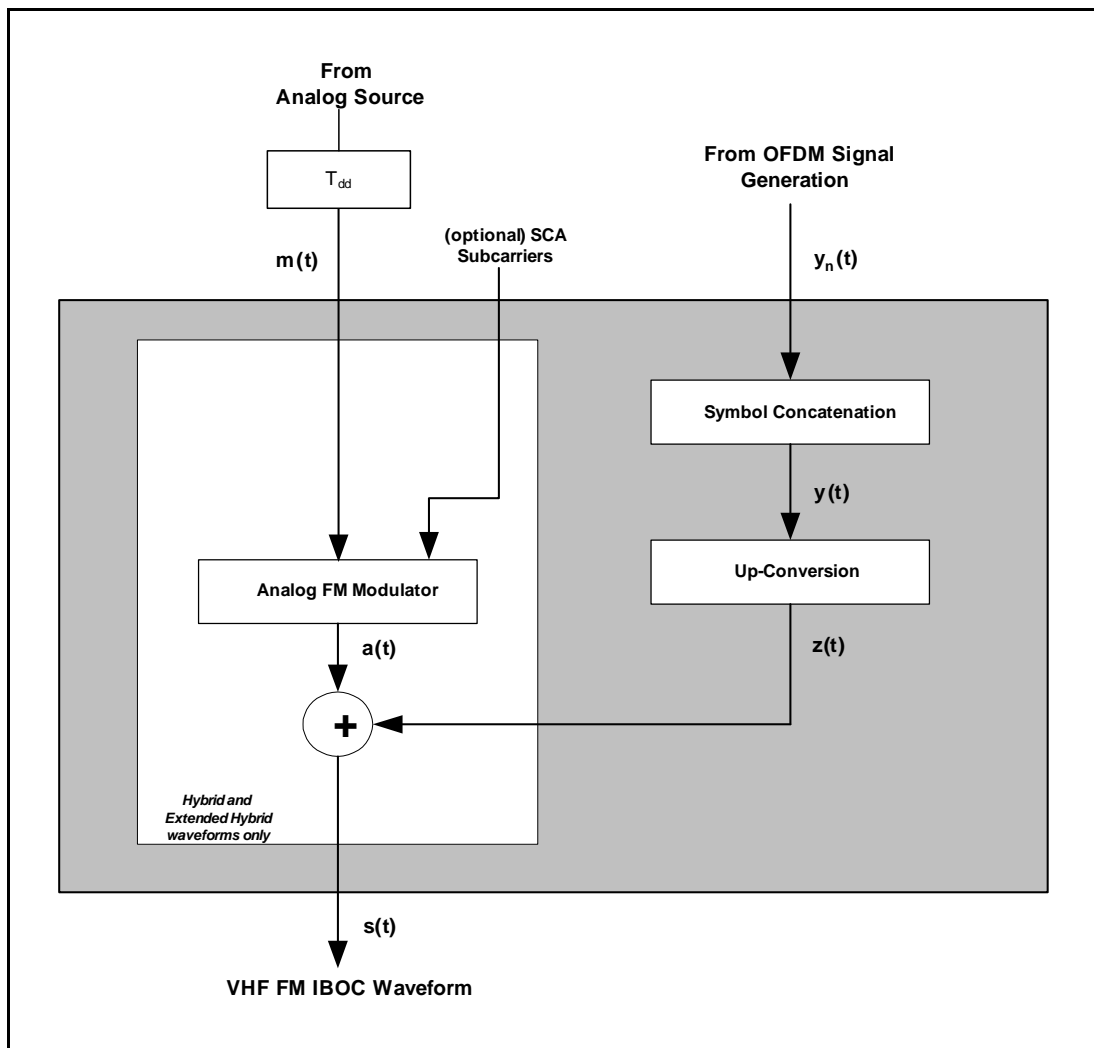

Figure 18: Hybrid/extended hybrid transmission subsystem functional block diagram

NRSC-5

For hybrid transmissions, noise and spuriously generated signals from all sources, including phase noise and intermodulation products, shall conform to the limits as described in Section 4.4.1 of reference [6] and shown in Figure 19.⁴

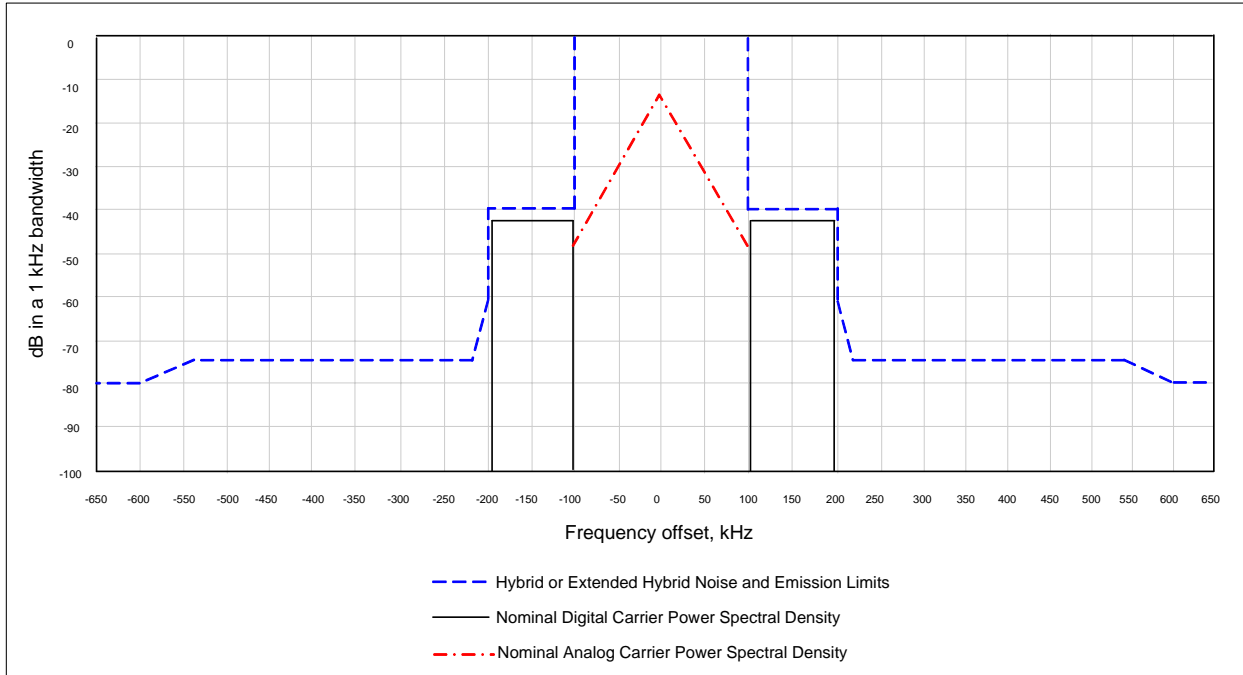
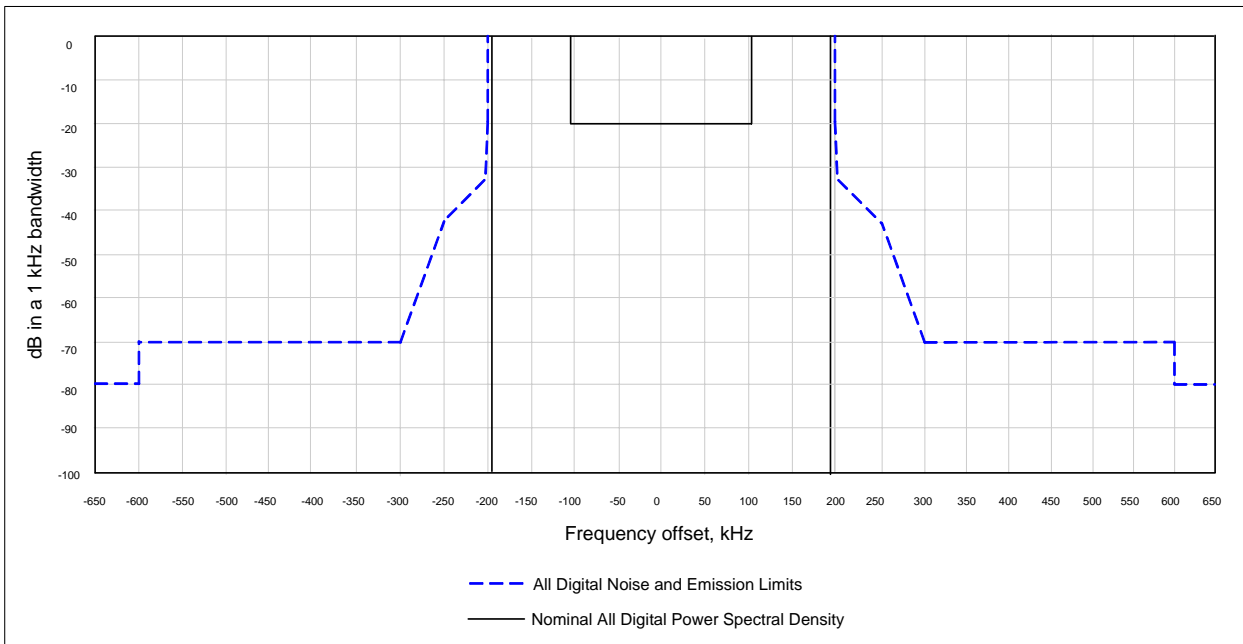

Figure 19. NRSC-5 FM hybrid waveform noise and emission limits

For all-digital transmissions, noise and spuriously generated signals from all sources, including phase noise and intermodulation products, shall conform to the limits as described in Section 4.4.2 of reference [6] and shown in Figure 20.



⁴ The requirements for noise and spurious emission limits illustrated in figures 19 & 20 reflect acceptable performance criteria. In certain circumstances, additional measures (filtering, active emissions suppression, etc.) may be needed to reduce the spectral emissions below the limits given in this subsection in order to reduce mutual interference between broadcast stations.

NRSC-5

Figure 20. NRSC-5 all-digital waveform noise and emission limits

There are several issues of time alignment that the transmission system must address. For transmit facilities so equipped, every L1 frame transmitted must be properly aligned with GPS time. Also, the various logical channels must be properly aligned with each other and in some service modes some channels are purposely delayed by a fixed amount to accommodate diversity combining at the receiver. Layer 1 provides for the time alignment of the transfer frames received from the channel multiplex. The higher protocol layers provide alignment of the contents of the transfer frames.

5 TRANSPORT AND SERVICE MULTIPLEX CHARACTERISTICS

This section specifies how control signals and non-audio information are passed through the IBOC digital radio system up to, but not including the RF/transmission subsystem.

The IBOC digital radio broadcasting system specified by the NRSC-5 Standard allows a broadcast station to offer multiple services. A service can be thought of as a logical grouping of application data identified by the IBOC digital radio system. Services are grouped into one of three categories:

1. Core services:
 - a. Main Program Service (both Audio (MPA) and Data (PSD))
 - b. Station Information Service (SIS)
2. Supplemental services:
 - a. Supplemental Program Service (SPS – both audio and data)
3. Advanced Data Services (ADS)

The flow of service content through the IBOC digital radio broadcast system is as follows:

1. Service content enters the IBOC digital radio broadcast system via service interfaces;
2. Content is assembled for transport using a specific protocol;
3. It is routed over logical channels via the channel multiplex;
4. And finally it is waveform modulated via the RF/transmission subsystem for over-the-air transmission.

Figure 2 is an overview of the AM band IBOC digital radio broadcast system and Figure 12 is an overview of the FM IBOC digital radio broadcast system. The following sections present a brief description of the IBOC digital radio core, supplemental, and advanced data services framework.

5.1 Core Services Overview

5.1.1 Main Program Service (MPS)

The main program service (specified in reference [4] and reference [7]) is a direct extension of traditional analog radio. The IBOC format enables the transmission of existing analog radio-programming in both analog and digital formats. This allows for a smooth transition from analog to digital radio. Radio receivers that are not IBOC digital radio enabled can continue to receive the traditional analog radio signal, while IBOC digital radio enabled receivers can receive both digital and analog signals via the same frequency band. In addition to digital audio, MPS includes digital data related to the audio programming. This is also referred to as MPS Data or Program Service Data (PSD).

5.1.2 Station Information Service (SIS)

The Station Information Service (specified in reference [5]) provides the necessary radio station control and identification information, such as station call sign identification, time and location reference information. SIS can be considered a built-in service that is readily available on all IBOC digital radio stations.

5.2 Supplemental Services Overview

5.2.1 Supplemental Program Service (SPS)

The supplemental program service (specified in reference [4] and reference [7]) is a direct extension of MPS in FM IBOC digital radio transmissions. SPS allows the transmission of additional audio content in digital format. This allows for additional audio programs to be broadcast on the same carrier. Multiple

NRSC-5

(up to 7) SPS channels or programs may be transmitted simultaneously. The system allows broadcasters to reallocate capacity that could otherwise be used for MPS or data in order to allow for this configuration.

A station's broadcast of SPS will not affect a receiver's ability to receive traditional analog radio signals or MPS transmissions, even if the receiver is not SPS enabled. In addition to digital audio, SPS includes digital data related to the audio programming. This is also referred to as SPS Data or program service data (PSD).

5.3 Advanced Data Services

Advanced data services will be incorporated into this Standard and more fully detailed in additional reference documents at a later date. Advanced data services provide broadcasters with the ability to transmit information that may be unrelated to MPS, SIS or SPS. These services can carry any form and content that can be expressed as a data file or a data stream, including audio services. Examples of such services include (i) visual effects associated with MPS, SIS, or SPS services; (ii) multimedia presentations of stock, news, weather, and entertainment programming including audio, text and images; (iii) broadcast updates to in-vehicle systems; (iv) local storage of content for time shifting and later replay; (v) targeted advertising; and (vi) traffic updates and information for use with navigation systems.

To ensure that each radio station can manage its bandwidth to support one or more data services, a transport for advanced data services will be developed and standardized. It should include a protocol for packetizing and transporting data from different services on the available bandwidth on the IBOC channel. The rate of data flow supported by the advanced data services transport system is dependent on the operating mode of the system and the capacity devoted to MPS and SPS. Reductions in the system capacity devoted to MPS and SPS will result in greater capacity for advanced data services.

A station's broadcast of advanced data services should not affect a receiver's ability to receive traditional analog radio signals, MPS or SPS transmissions, even if the receiver is not able to receive advanced data services.

Note that information relating to the iBiquity advanced application service (AAS) in the normative reference documents is considered informative with respect to the NRSC-5 standard at this time.

5.4 Core Services Description

5.4.1 Main Program Service (MPS)

The following sections describe the MPS audio and data interfaces and transports.

5.4.1.1 MPS Audio

Figure 21 details the interface of the audio encoder for the IBOC digital radio system.⁵ The audio encoder receives input audio frames from the audio interface application and encodes the audio data. The encoded audio is combined with MPS data, and sent to the channel multiplex (Layer 2) as an audio codec protocol data unit (PDU). The audio codec PDU is comprised of compressed audio and PSD. This process is specified in reference [4].

⁵ This standard does not specify an encoder. In order to determine the system's viability the NRSC evaluated it using the HD Codec developed by iBiquity and Coding Technologies.

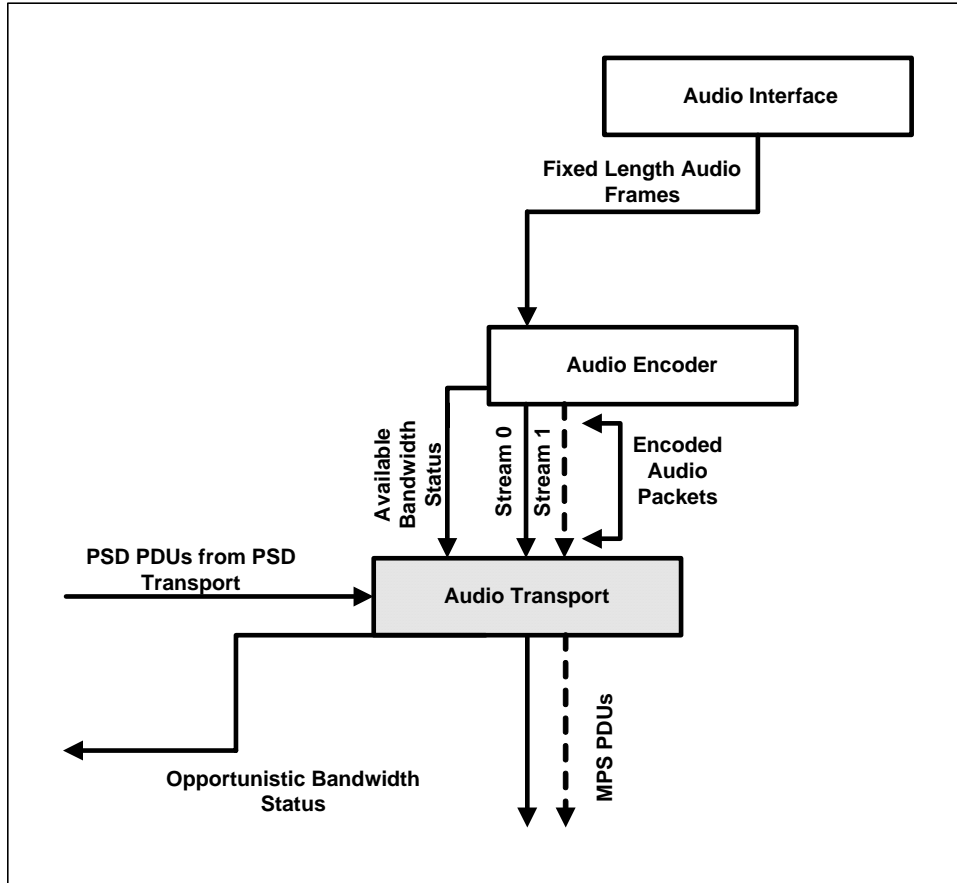

Figure 21: Audio codec protocol interface diagram

The audio frame, packet and PDU are defined as:

- Audio frame** The unit of information payload exchanged from the audio interface and the audio codec protocol layer. Audio frames are typically comprised of 1024 audio samples at a sampling rate of 44.1 kHz using 16 bit pulse code modulation (PCM).
- Audio encoded packet** Compressed audio frames output from the audio encoder. These may be divided into one to three output streams depending on the audio encoder mode.
- Audio codec PDU** This is the output of the audio transport process. An audio codec PDU consists of protocol information followed by a sequence of audio encoded packets. Audio codec PDUs may be output on from one to three streams depending on the audio encoder mode.

5.4.1.2 MPS Data Interface and Transport

The MPS allows data to be transmitted in tandem with program audio. The data is intended to describe or complement the audio program that the radio listener is hearing.

MPS data (fully specified in reference [7]) defines a specific set of data fields (e.g., artist, title, etc.). The fields can be used for all forms of audio programming. For example, the “title” field may immediately seem to apply only to song titles. However, it also applies to titles for commercials, announcements, and talk programs.

NRSC-5

The core fields include the following:

Title	Equivalent to a one-line title name
Artist	Performer, originator, author, sponsor, show host.
Album	Content source , such as album name, show name, sponsor name
Genre	Categorization of content. This is an enumerated field of predefined types, such as Jazz, Rock, Speech, etc.
Comment Title	One-line title for comment description
Comment Description	Detail description, user call-back or other information, such as talk show call in number or web-site URL.
Commercial	Collection of fields that support detailed product advertisement and purchasing, including: <ul style="list-style-type: none">- Price of merchandise- Expiration data for transaction- Transaction method- URL which could be used to initiate purchase transaction via an external return channel- Advertisement description- Seller identification
Reference Identifiers	Identifiers that can be used to uniquely identify the MPS data message

The MPS Data is transmitted within the audio transport. The SPS transport is identical to the MPS transport. Both services contain identical header and data structures. See references [7] and [9] for further details.

5.4.2 Station Information Service (SIS)

A description of the SIS interface and transport is provided in the following sections.

5.4.2.1 SIS Interface

The station information service interface allows broadcasters to transmit the following information:

Station Name	<i>Station Name</i> identifies the station call sign. For example, station <i>WXXX</i> or <i>WYYY-FM</i> . In addition, to traditional call sign identification, broadcasters can also transmit long station names such as <i>MD SMOOTH JAZZ</i> or <i>WXYX ROCK N ROLL</i> .
Station ID Number	<i>Station ID Number</i> is a unique numerical identifier that identifies the Federal Communications Commission (FCC) approved broadcast station. The Station ID Number is made up of the following information: i) Country Code, and ii) FCC facility ID.
Station Location	<i>Station Location</i> provides a 3-dimensional geographic station location, consisting of latitude, longitude, and altitude. It can, for example, be used for receiver position determination in advanced applications.
Absolute Layer 1 Frame Number (ALFN)	<i>System Time</i> can be derived from the ALFN. The system time can be used to provide accurate time clock synchronization for receivers. For IBOC digital radio stations synchronized to the Global Positioning System (GPS), ALFN reflects global GPS time.
SIS Parameter Message	<i>SIS Parameter Message</i> provides additional data to aid the receiver with position and time applications. This message includes data fields for leap second timing (GPS) and local time of day (time zone, daylight savings time setting, etc). IBOC digital radio receivers enabled with time-of-day applications use these parameters in combination with ALFN to compute the correct local time.

5.4.2.2 SIS Transport

The SIS is sent through the IBOC digital radio system via a dedicated logical channel. The channel multiplex routes SIS content to a dedicated SIS logical channel in the RF/transmission subsystem. For more information on the SIS transport, see reference [5].

5.5 Channel Multiplex

The channel multiplex allows the IBOC digital radio system to support independent transports for the following services:

1. Main program service audio and MPS data
2. Supplemental program service audio and SPS data
3. Advanced application services
4. Station information service

The channel multiplex is aware of the audio transport configuration requirements (e.g., channel mapping and bandwidth requirements). This allows for a high-level of synchronization between the analog and digital program audio streams. The channel multiplex has the flexibility to dynamically allocate unused MPS/SPS bandwidth for advanced data services.

The station information service passes through the channel multiplex without any additional processing.

5.5.1 Interface to RF/transmission subsystem

The RF/transmission subsystem interface provides a group of logical channels. Each channel is distinguished by the following characteristics:

- Channel identifier
- Transfer frame size
- Transfer frame rate
- Channel robustness
- Channel latency

Depending on the RF/transmission service mode, the number of logical channels will vary. The channel multiplex is synchronized to the RF/transmission clock rate. The channel multiplex is signaled at each channel transmission opportunity by the RF/transmission subsystem. A complete transfer frame for each logical channel is delivered to the RF/transmission system for broadcast transmission.

For more information on the channel multiplex, see reference [3].

5.5.2 Configuration Administrator

Control of the IBOC digital radio system is handled by the “configuration administrator” function as shown in Figure 2 and Figure 12. The AM or FM modem mode (e.g., MP1, MP2 etc.), bandwidth allocations, and specific information being sent across the logical channels (e.g., P1, P2, etc.) are controlled by the configuration administrator. This function represents the processes for communicating conditions and settings to and among the various transports and functional blocks, and will vary from implementation to implementation—its structure and detail are not specified by NRSC-5.

6 AUDIO ENCODER CHARACTERISTICS

This section specifies some of the characteristics of audio codecs designed for use with the NRSC-5 IBOC digital radio system. As noted above, NRSC-5 does not include specifications for audio source coding and compression. Suitable audio source coding and compression systems will use perceptual audio coding or other appropriate technologies to reduce the bit rate required for description of audio signals.

6.1 Coding rates

Table 1 shows the default audio bit rates for each audio codec mode. Minimum bit rates are shown in Table 2.

Table 1. Default audio bit-rate as a function of audio codec mode⁶

Audio Codec Mode	Typical use	Stream Type	Nominal Bit Rate (kbps)
0000	FM hybrid, extended hybrid (MP1-MP4)	Core	96
0001	FM all-digital (MP6)	Core	48
		Enhanced	48
0010	AM hybrid (MA1)	Core	20
		Enhanced	16
	AM all-digital (MA3)	Core	20
		Enhanced	20
0011	FM all-digital (MP5)	Core	24
		Enhanced	72
1010	FM Supplemental Program Service	Core	22
		Enhanced	24
1101	FM Supplemental Program Service	Core	24

Table 2. Nominal and minimum bit rates as a function of audio codec mode⁷

Audio Codec Mode	Typical use	Nominal bit rate (kbps)	Minimum bit rate (kbps)†
0000	FM hybrid	96	24
0001	FM all-digital	96	24
0010	AM hybrid	36	20
	AM all-digital	40	20
0011	FM all-digital	96	24
1010	FM SPS	46	22
1101	FM SPS	24	12

†These values reflect useful rates. "0" rate could also be considered but that reflects an inactive code.

⁶ From reference [4], section 5.2.1.1, Table 5-2.

⁷ From reference [4], section 5.2.1.1, Table 5-3.

6.2 Opportunistic Data

When an audio encoder does not use all of the bytes allocated to its use of the layer 2 PDU, the unused capacity can be made available as "opportunistic data" capacity. Opportunistic data is allocated independently on each PDU, such that there is no guarantee of a delivery rate in a series of transmitted PDU's. The effective data rate of opportunistic data is highly dependent on the characteristics of the audio program and the resulting quantity of data required to represent the coded audio. Effective opportunistic data rates typically range from zero to several kilobits per second. The relationship between fixed, opportunistic, and other data capacities on the layer 2 channel multiplex is described in detail in reference [3].

* * *

NRSC Document Improvement Proposal

If in the review or use of this document a potential change appears needed for safety, health or technical reasons, please fill in the appropriate information below and email, mail or fax to:

National Radio Systems Committee
c/o Consumer Electronics Association
Technology & Standards Department
2500 Wilson Blvd.
Arlington, VA 22201
FAX: 703 907-7693
standards@ce.org

Document No.	Document Title:
Submitter's Name:	Telephone No.:
Submitter's Company:	FAX No.:
	e-mail:
Address:	
Urgency of Change:	
<input type="checkbox"/> Immediate <input type="checkbox"/> At next revision	
Problem Area:	
a. Clause Number and/or Drawing:	
b. Recommended Changes:	
c. Reason/Rationale for Recommendation:	
Additional Remarks:	
Signature:	Date:
FOR NRSC USE ONLY	
Responsible Committee:	
Co-chairmen:	
Date comments forwarded to committee co-chairmen:	

