



**NATIONAL
RADIO SYSTEMS
COMMITTEE**



D A B S u b c o m m i t t e e

**In-band/On-channel (IBOC)
Digital Audio Broadcasting (DAB)
System Test Guidelines**

Part I – Laboratory Tests

(as adopted by the Subcommittee on December 3, 1998)

Table of Contents

1	INTRODUCTION	4
2	PROPONENT SUBMISSIONS TO THE NRSC	6
3	DEFINITIONS	8
4	SUBJECTIVE EVALUATION GUIDELINES	10
4.1	FORMAL SUBJECTIVE EVALUATION.....	10
4.2	INFORMAL SUBJECTIVE EVALUATION.....	13
5	LABORATORY TEST GUIDELINES	15
5.1	FM-BAND PORTION.....	16
5.1.1	<i>Test A - System Calibration</i>	16
5.1.2	<i>Test B - IBOC system performance with AWGN</i>	16
5.1.3	<i>Test C - IBOC system performance with special impairments</i>	17
5.1.4	<i>Test D - IBOC “digital-to-digital” compatibility performance</i>	18
5.1.5	<i>Test E - IBOC “digital-to-digital” compatibility performance in a multipath fading channel</i>	18
5.1.6	<i>Test F - IBOC “digital-to-analog” compatibility performance</i>	19
5.1.7	<i>Test G - IBOC “digital-to-analog” compatibility performance in a multipath fading channel</i>	19
5.1.8	<i>Test H - IBOC “analog-to-digital” compatibility performance</i>	20
5.1.9	<i>Test I - IBOC “analog-to-digital” compatibility performance in a multipath fading channel</i>	20
5.1.10	<i>Test J - IBOC acquisition/reacquisition performance</i>	21
5.1.11	<i>Test K – DAB quality</i>	21
5.1.12	<i>Test L - IBOC “digital-to-host analog” compatibility performance</i>	22
5.1.13	<i>Test M - IBOC “host analog-to-digital” compatibility performance</i>	22
5.2	AM-BAND PORTION.....	24
5.2.1	<i>Test A - System Calibration</i>	24
5.2.2	<i>Test B - IBOC system performance with AWGN</i>	24
5.2.3	<i>Test C - IBOC system performance with special impairments</i>	24
5.2.4	<i>Test D - IBOC “digital-to-digital” compatibility performance</i>	25
5.2.5	<i>Test F - IBOC “digital-to-analog” compatibility performance</i>	25
5.2.6	<i>Test H - IBOC “analog-to-digital” compatibility performance</i>	26
5.2.7	<i>Test J - IBOC acquisition/reacquisition performance</i>	26
5.2.8	<i>Test K – DAB quality</i>	27
5.2.9	<i>Test L - IBOC “digital-to-host analog” compatibility performance</i>	27
5.2.10	<i>Test M - IBOC “host analog-to-digital” compatibility performance</i>	27

List of Appendices

APPENDIX A. RECOMMENDED LAB TEST OUTLINE – FM-BAND.....28

APPENDIX B. RECOMMENDED LAB TEST OUTLINE – AM-BAND.....42

APPENDIX C. ANALOG RECEIVER SELECTION (COMPATIBILITY TESTING)53

APPENDIX D. TEST MATRIX – LAB TEST GUIDELINES, FM-BAND PORTION56

APPENDIX E. TEST MATRIX – LAB TEST GUIDELINES, AM-BAND PORTION.....61

APPENDIX F. DAB SUBCOMMITTEE GOALS & OBJECTIVES64

APPENDIX G. IBOC STATUS REPORT (6/98).....66

List of Tables

TABLE 4-1 RECOMMENDED LEVELS OF AUDIO SUBJECTIVE EVALUATION – LABORATORY TESTS..... 14

TABLE 5-1. LABORATORY TEST GUIDELINES SUMMARY – IBOC SYSTEM, FM-BAND PORTION 15

TABLE 5-2. LABORATORY TEST GUIDELINES SUMMARY – IBOC SYSTEM, AM-BAND PORTION 15

List of Figures

FIGURE 1. ILLUSTRATION OF SUBJECTIVE EVALUATION PROCESS – UNIMPAIRED AUDIO QUALITY TESTING..... 11

FIGURE 2. ILLUSTRATION OF SUBJECTIVE EVALUATION PROCESS – IMPAIRMENT TESTING..... 12

1 Introduction

These test guidelines, developed by the Test Guideline Working Group (TGWG), Mr. Andy Laird, Chairman, of the DAB Subcommittee of the National Radio Systems Committee (NRSC), are the result of a cooperative effort between broadcasters, receiver manufacturers, and IBOC DAB system developers. Fundamentally, they describe the laboratory test results needed by the broadcasting and receiver manufacturing industries in order to assess the viability and desirability of proposed IBOC systems.

The development of these guidelines is perhaps the first substantive task undertaken by the DAB Subcommittee, since its re-activation in January of 1998, as it works towards fulfilling its goals and objectives as stated in Appendix F. Proponent submissions received by the NRSC which follow these guidelines can be expected to undergo a thorough review and analysis by the DAB Subcommittee, as it strives to determine whether or not submitted systems represent a significant improvement over the existing AM and FM analog radio transmission methods in use today, and otherwise appear to be viable IBOC DAB systems.

Unlike the prior DAB test program which the NRSC participated in, where multiple systems were tested simultaneously, these guidelines are designed to support independent testing of systems either by the proponents themselves (with third-party oversight, as discussed in Section 2) or by independent test contractors. In fact, the guidelines recognize that systems being designed by different organizations rarely develop according to the same schedule, and once developed, it is usually necessary to test them as quickly as possible so as to foster rapid deployment.

Given the open framework in which the NRSC conducts its activities, proponents can expect to be fully informed of the progress and direction of any evaluative efforts. Proponent participation is a vital aspect of this process, making it possible to be sure that any submissions are correctly interpreted and fairly judged. The NRSC looks forward to continued participation of the IBOC system proponents, as has been the case in the development of these test guidelines.

Included as an appendix to this test plan (Appendix G) is an article on the status of IBOC DAB as it existed at the time this test plan was drafted (presented at the Radio Montreux 1998 conference). This information is of interest since the technology and circumstances described therein had some influence on the formulation of the specific tests and procedures which appear in this document.

One aspect of current IBOC system development (referred to in Appendix F as "next-generation" systems) which was not in evidence in earlier developments ("first generation" systems, in Appendix G) was the so-called "all-digital IBOC" system design, which consists entirely of digital RF carriers and eliminates the analog AM or FM signal altogether. In recent Subcommittee deliberations, proponents have raised the issue of all-digital IBOC systems, and specifically, the integration of all-digital IBOC approaches with IBOC signals as they have been traditionally defined (consisting of both analog and digital carriers), as well as how the broadcasting industry might transition from traditional IBOC to all-digital IBOC.

The NRSC's sponsoring organizations (NAB and CEMA) have advised the DAB Subcommittee that for the purpose of the current investigations, traditional IBOC technology is

of paramount importance and that Subcommittee evaluations need to focus on these combined analog/digital IBOC signals.

Part II of these test guidelines, Field Tests, is currently under development. This document (Part I), combined with Part II when complete, fully defines the NRSC's requirements for IBOC system test results needed for its evaluative process to commence. Note that the release of these test guidelines documents in two parts is being done solely to help expedite the test process and *is not* meant to imply that submissions to the NRSC should be in two parts, as well. This guideline release schedule was selected to follow the natural progression of system development, which is from the laboratory into the field, and allows the NRSC to provide IBOC proponents with its test guidelines in the most timely fashion possible.

As fully explained in Section 2, proponent submissions are expected to be complete and include any and all laboratory and/or field test data which the proponent wishes the NRSC to consider.

2 Proponent Submissions to the NRSC

Proponents need to submit the following information to the NRSC in order for the DAB Subcommittee to be able to effectively evaluate their system:

- a) Detailed system description including:
 - i) High level description and theory of operation
 - ii) Transmission equipment description / requirements
 - iii) Receiver equipment description / requirements
 - iv) Compliance with (or changes necessary to) FCC rules
- b) Description of test procedures followed – note that Appendices A and B include suggested laboratory test procedures which are based on the experience gained by the NRSC in its prior DAB test efforts (Part II of these guidelines will include similar information for field testing). It is especially important that proponents electing to use test procedures which differ significantly from the suggested procedures provide detailed information on the procedures which were followed.
- c) Statement of oversight – proponents are expected to retain an independent, third-party observer (preferably an expert in broadcast and/or digital communications engineering) who will follow and/or review the system testing (done by the proponent) closely and personally certify the submitted results as an accurate record of the actual measured system performance. Alternatively, proponents may elect to make use of an independent system testing contractor for implementation of the test program.

This is a vital part of the proponent submission, which will allow the NRSC to evaluate with confidence the proponent-submitted data as an accurate depiction of performance.

- d) Test results obtained using procedures described in b) above. Proponents are strongly encouraged to follow the labeling and other conventions regarding test results established in this test guidelines document.

In accordance with DAB Subcommittee policy, data submissions (system descriptions, test procedures, test results, etc.) made by IBOC proponents to the NRSC for purposes of evaluation must be:

- on complete systems, that is, systems which provide for IBOC DAB in both the AM and FM bands. A submission made on a system which only operates in one of these bands will only be considered if, along with that submission, the proponent states its intention to *only* support IBOC operation in that single band, and furthermore, why they have elected not to develop a system which supports operation in both bands. Note that in such instances, the NRSC may elect not to evaluate the submission, in particular if submissions have been made by other proponents which support operation in both bands.
- made at the conclusion of the system development effort, that is, must represent the performance of a completed system. Test results taken on partially completed systems and/or preliminary results from (comprehensive) test programs will not be accepted, nor will multiple submissions (e.g., revised submissions) for a system already submitted.

Again, proponents are strongly encouraged to follow the NRSC IBOC System Test Guidelines (i.e. this document and Part II, Field Tests, when available) when preparing a submission, and indicate as part of their submission which desired test results (as stated in the Guidelines) are included. Appendices C and D (system test matrices) of this document were developed to serve as “checklists” which proponents can include with their submission, providing a straightforward way to indicate which requested test results have been obtained (similar checklists will be included in Part II).

3 Definitions

Acquisition/re-acquisition performance – the aspect of IBOC system performance characterized by the length of time needed to acquire (initially) or re-acquire (after an interruption in service) an IBOC transmission.

Analog main channel audio performance – performance (objective and/or subjective) of the analog main channel audio portion of a sound broadcasting transmission, either AM or FM, IBOC or (traditional) analog.

Bit Error Rate (BER) – a measure of digital system performance, simply, the ratio of the number of bits received in error, to the total number of bits received.

Co-channel signal – the RF signal co-located with, i.e. having the same center frequency as, a desired sound broadcasting signal. Note that the co-channel signal, for the purposes of IBOC DAB system evaluation, can be either a standard analog signal or an IBOC DAB signal.

Data transmission performance – performance of that portion of the IBOC system set aside for data transmission specifically (i.e. not used to carry the digital audio bit stream), typically characterized by BER, FER, etc. As used in Section 5 and unless otherwise indicated, this term refers to the performance of the “auxiliary” or “ancillary” data transmissions (terms often used by IBOC proponents and others to describe this portion of the system).

Desired signal – refers to a sound broadcasting signal (AM or FM, IBOC or non-IBOC) under test.

Digital audio performance – performance (objective and/or subjective) of the digital audio portion of the IBOC system.

First adjacent signal – the RF signal located either ± 200 kHz (for FM) or ± 10 kHz (for AM) away from the center frequency of a desired sound broadcasting signal. Note that the first adjacent signal, for the purposes of IBOC DAB system evaluation, can be either a standard analog signal or an IBOC DAB signal.

Frame – a particular segmentation of bits (or bytes) occurring within a system by virtue of some aspect of the system's design. For example, audio coding schemes such as PAC and MPEG-2 AAC format the coded digital audio data streams into frames of a specific definition, delineated by specific patterns of bits (e.g., headers, etc.) and with a predefined structure.

Frame Error Rate (FER) – a measure of digital system performance, simply, the ratio of the number of frames received in error, to the total number of frames received.

Host analog main channel audio performance – performance (objective and/or subjective) of the analog main channel audio portion of an IBOC system, considered to be the “host” to the IBOC digital carriers.

Host signal – the analog (AM or FM) sound broadcast signal which exists in the same channel as the digital portion of an IBOC DAB signal.

Host subcarrier performance – performance (objective and/or subjective) of the subcarrier (i.e.

SCA) signals associated with the analog carrier portion of an IBOC system (typically applies to FM systems only).

In-band/on-channel (IBOC) DAB – a method of digital audio broadcasting in which a digital audio signal is combined, in a mutually compatible fashion, with an existing analog audio signal (either AM or FM), in such a manner as to be consistent with the FCC rules (present or future) for AM and FM sound broadcasting.

Second adjacent signal – the RF signal located either ± 400 kHz (for FM) or ± 20 kHz (for AM) away from the center frequency of a desired sound broadcasting signal. Note that the second adjacent signal, for the purposes of IBOC DAB system evaluation, can be either a standard analog signal or an IBOC DAB signal.

Third adjacent signal – the RF signal located either ± 600 kHz (for FM) or ± 30 kHz (for AM) away from the center frequency of a desired sound broadcasting signal. Note that the third adjacent signal, for the purposes of IBOC DAB system evaluation, can be either a standard analog signal or an IBOC DAB signal.

Undesired signal – refers to a sound broadcasting signal (AM or FM, IBOC or non-IBOC), present along with a desired signal, as either a co-channel or adjacent channel signal.

4 Subjective evaluation guidelines

One of the most vital aspects of IBOC system evaluation involves subjective evaluation of the audio quality of the digital signal, in both unimpaired and impaired situations, as well as evaluation of the audio quality of analog audio signals affected by the presence of the IBOC digital signal energy. These analog signals include the IBOC host signal, co- and adjacent-channel standard analog (i.e. non-IBOC) signals, as well as the analog portion of co- and adjacent-channel IBOC signals.

4.1 Formal subjective evaluation

Within the general category of “formal” subjective evaluation of audio signals there are, for the purposes of this test guidelines document, two recommended approaches:

- TOA/POF determination – typically, when subjecting a signal to channel impairments (e.g., AWGN, co- and adjacent-channel interference), the threshold of audibility (TOA) and point of failure (POF) are subjectively determined by one or more expert listeners involved in the testing of the system.

TOA is defined as the system operating point (characterized by the impairment level, for example, the amount of AWGN, or the d/u ratio of a particular interfering signal) at which degradations in the audio are first detectable.

POF corresponds to the operating point where the audio signal just becomes so degraded as to be unusable, and is defined as a “1” on the ITU-R continuous 5-grade impairment scale (very annoying).

For submissions to the NRSC in which TOA/POF data are suggested (tests A-E, H, I, and M) proponents are expected to submit (along with the data) audio tapes with examples of audio determined to be at TOA and POF.

- Listening tests – for determining unimpaired audio quality, and in certain cases involving channel impairments, the audio quality of the system under test (“audio under test”) is recorded onto digital audio tape (DAT), and compared to a suitable audio “reference” by a panel of trained, expert listeners who assess the level of impairment of the audio under test (with respect to the reference). Procedures for conducting such listening tests have been standardized by the ITU and others.¹

In the particular case of unimpaired audio quality characterization, the NRSC has determined, for the purposes of its IBOC system evaluations, that the appropriate reference material to be used in a listening test of this sort is obtained by recording a digital audio source (CD or DAT) through an AM and possibly FM (for AM IBOC evaluation) or FM (for FM IBOC evaluations) broadcast signal chain, using an appropriate receiver. This process is illustrated

¹ Methods for the subjective assessment of Small Impairments in Audio Systems Including Multichannel Sound Systems, ITU-R Recommendation B.S.1116; Grusec, T., Thibault, L., & Soulodre, G. Subjective evaluation of high quality audio coding system: Methods and results in the two-channel case, *AES preprint 4065*, *AES 99th Convention*, October 6-9, 1995, New York.

conceptually in Figure 1, where it is emphasized that the subjective comparison does not involve the original digital audio source material.

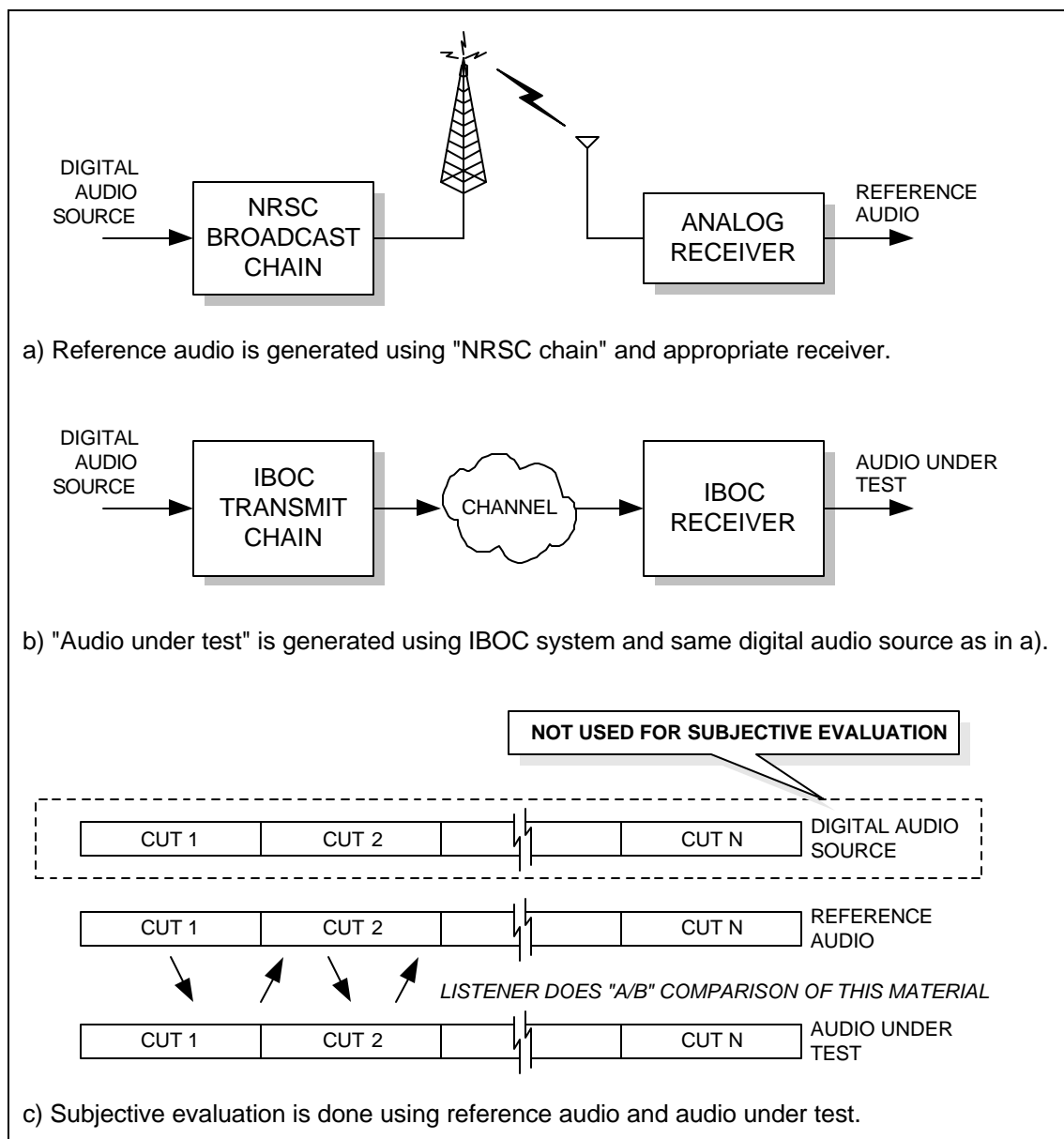

Figure 1. Illustration of subjective evaluation process – unimpaired audio quality testing

The NRSC has prepared DAT recordings of carefully selected audio materials, sent through processed and unprocessed AM and FM broadcast chains, then taken “off-air” using suitable receivers, for use as reference material in IBOC system evaluations, and will provide these tapes, along with the digital source material (in CD or DAT format), to proponents at their request, for use in IBOC system testing.

In the case of impairment tests, the process for obtaining an appropriate reference for subjective evaluation is illustrated conceptually in Figure 2. Note that for a particular set of tests

(e.g., Test F - digital to analog compatibility) the reference for each portion of the test (e.g., co-channel, 1st-adjacent, etc.) will in general be different, corresponding to the nature of the interference for each portion.

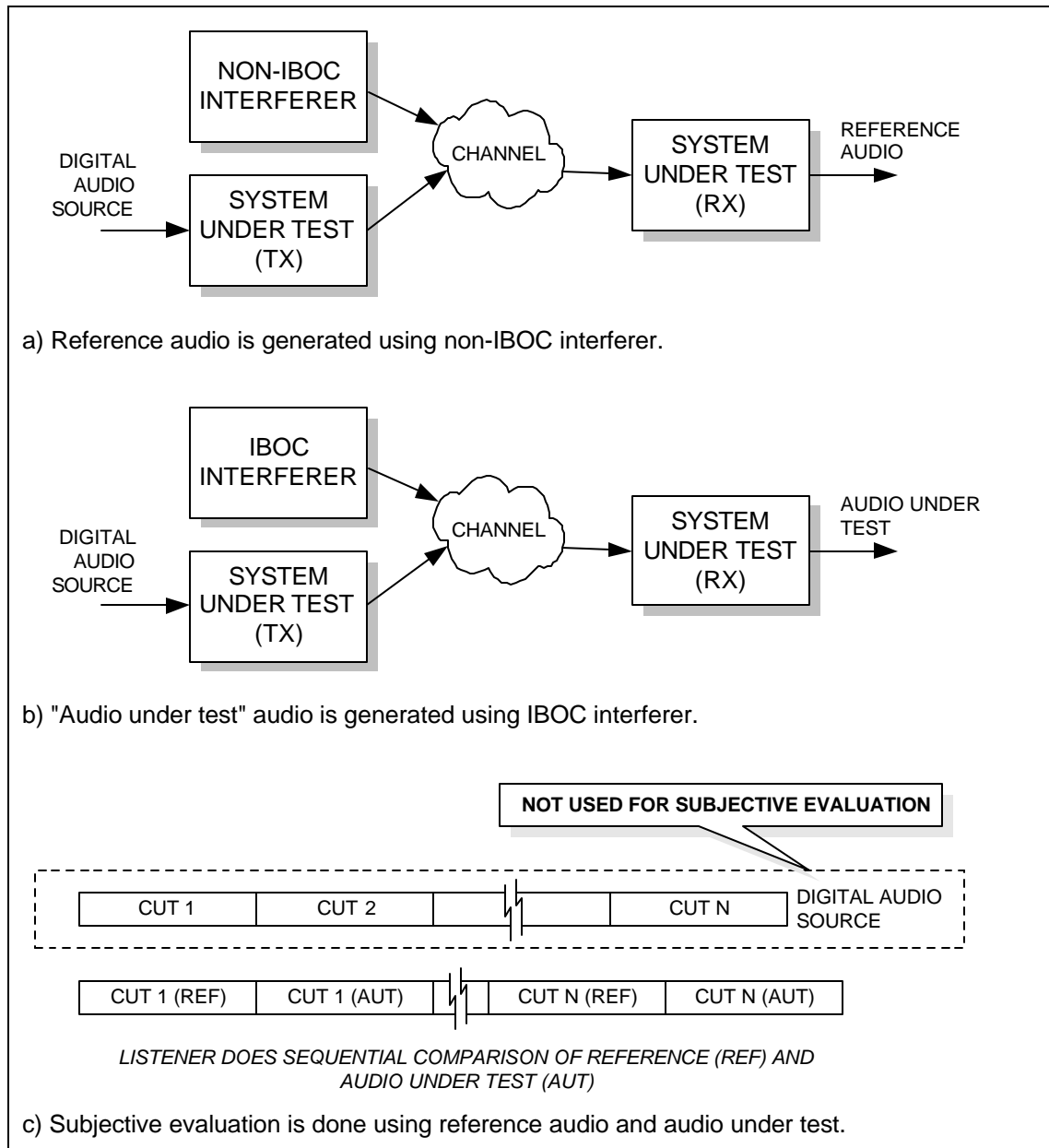

Figure 2. Illustration of subjective evaluation process – impairment testing

Also note that the subjective evaluation illustrated in Figure 2 is not an “A/B” test but instead consists of sequential comparisons of audio cuts. This method of testing was used by the NRSC in its earlier DAB test program, for subjective evaluation of impaired audio (not unimpaired quality testing), because of the sheer number of audio materials needing to be compared. In these cases, rather than using the continuous 5-grade impairment scale, a simpler 3-grade (“same as, better than, worse than” reference) scale was used. Data taken in

this manner, while departing somewhat from ITU-R recommendations, will be acceptable to the NRSC for impairment test results *only*.

For submissions to the NRSC in which listening test-type data are suggested (tests F, G, K, and L), proponents are expected to submit a detailed report which includes a description of how the listening tests were performed and by whom, the listening test results, and the audio tapes which were used to perform the listening tests.

Table 4-1 indicates the subjective evaluation approach being recommended by the NRSC for specific categories of IBOC system laboratory tests.

4.2 Informal subjective evaluation

While the guidelines for subjective evaluation just presented offer a scientific basis for judging the digital audio quality of proposed systems, the results thus obtained lack a “real-world” quality which broadcasters and receiver manufacturers also need in order for a thorough assessment of audio quality to be conducted.

Consequently, the NRSC has prepared a “long-form” digital audio tape (DAT) containing audio material representative of the many different programming “formats” that radio broadcasters’ utilize. This long-form audio, including announcer voice-overs, “jingles,” and the like, will be provided to IBOC proponents expressing an interest in having the NRSC evaluate their systems. A DAT tape of this material, as received by the IBOC system in an unimpaired environment, should then be submitted to the NRSC along with the more formal subjective evaluation material.

In this manner, the NRSC will have an opportunity to listen to digital audio as if it were being used for a real broadcast, and perhaps get more of a “feel” for the IBOC system audio quality than is possible by listening to the audio materials used in the more critical subjective evaluations alone.

Table 4-1 Recommended levels of audio subjective evaluation – laboratory tests

Test	Description	Subjective evaluation				Comments
		Audio under test	TOA, POF	Listening tests	Reference audio	
A	System calibration	IBOC digital	✓			
B	Performance with AWGN	IBOC digital	✓			
C	Performance with special impairments	IBOC digital	✓			Impairments include impulse noise, airplane flutter, weak signal, et.al.
D	D→D compatibility, linear channel	IBOC digital	✓			
E	D→D compatibility, multipath channel †	IBOC digital	✓			
F	D→A compatibility, linear channel	Std. analog (non-IBOC signal)		✓	Through system (non-IBOC interferer) – see Figure 2	Different reference material used for each case (e.g., co-channel, 1st-adj. chnl., etc.)
G	D→A compatibility, multipath channel †	Std. analog (non-IBOC signal)		✓	Through system (non-IBOC interferer) – see Figure 2	Different reference material used for each case (e.g., co-channel, 1st-adj. chnl., etc.)
H	A→D compatibility, linear channel	IBOC digital	✓			
I	A→D compatibility, multipath channel †	IBOC digital	✓			
J	Acquisition/reacquisition performance	n/a				
K	DAB quality	IBOC digital		✓	NRSC broadcast chain reference DAT – see Figure 1	Recommend unprocessed FM DAT for FM IBOC ref.; processed FM DAT and/or processed AM DAT for AM IBOC ref.
L	D→Host analog compatibility	Host analog		✓	Host analog performance with IBOC digital carriers disabled	
M	Host analog→D compatibility	IBOC digital	✓			

† Test not performed for AM IBOC

5 Laboratory test guidelines

Table 5-1 and Table 5-2 below summarize the laboratory test guidelines for IBOC systems (FM-band and AM-band portions, respectively). Note that the designations in the TEST NO. field (in each table) correspond to the test designations used in the EIA/NRSC DAR tests performed in the 1994-96 time frame.

Proponents are referred to Appendices A and B which contain suggested test procedures for laboratory tests. These procedures are recommended but not required, and are based on the test procedures used by the EIA/NRSC in its earlier evaluation of DAB systems.

Table 5-1. Laboratory Test Guidelines Summary – IBOC system, FM-Band portion

SECTION	TEST NO.	DESCRIPTION	COMMENTS
5.1.1	A	Calibration	
5.1.2	B	Impairment tests for characterization of DAB signal failure	
5.1.3	C	DAB with special impairments	
5.1.4	D	DAB → DAB	
5.1.5	E	DAB → DAB with multipath	
5.1.6	F	DAB → analog	
5.1.7	G	DAB → analog with multipath	
5.1.8	H	Analog → DAB	
5.1.9	I	Analog → DAB with multipath	
5.1.10	J	DAB acquisition and reacquisition	
5.1.12	K	DAB quality	
5.1.13	L	DAB → host analog	
5.1.13	M	Host analog → IBOC digital	

Table 5-2. Laboratory Test Guidelines Summary – IBOC system, AM-Band portion

SECTION	TEST NO.	DESCRIPTION	COMMENTS
5.2.1	A	Calibration	
5.2.2	B	Impairment tests for characterization of DAB signal failure	
5.2.3	C	DAB with special impairments	
5.2.4	D	DAB → DAB	
5.2.5	F	DAB → analog	
5.2.6	H	Analog → DAB	
5.2.7	J	DAB acquisition and reacquisition	
5.2.8	K	DAB quality	
5.2.9	L	DAB → host analog	
5.2.10	M	Host analog → IBOC digital	

5.1 FM-band portion

5.1.1 Test A - System Calibration

Purpose: To constantly maintain IBOC system hardware and associated test equipment in a known, calibrated state, and to establish clear and complete documentation of that state.

Desired results:

- 1) Average and peak RF power measurements of IBOC signal;
- 2) RF spectrum plot showing shape and spectral occupancy of IBOC signal;
- 3) Digital audio subjective performance baseline—using “Threshold of Audibility” (TOA) or some other subjective criteria—versus AWGN (linear channel);
- 4) Baseline characterization of system digital performance, both digital audio and data transmission paths (BER, FER, or other similar parameter) versus AWGN (linear channel);
- 5) Analog proof-of-performance test results (frequency response, distortion characteristics of main channel audio, etc.);
- 6) Calibration record of equipment used for testing.

Comments:

- Systems should be calibrated regularly to insure precise and accurate test data;
- Suggested settings for RF spectrum plots – RES BW 1 kHz, VBW 30 Hz, sweep span 500 kHz;
- Multiple data points (BER, FER, etc.) should be collected so as to allow for performance versus carrier-to-noise ratio data plots;
- Calibration records should be signed and dated.

5.1.2 Test B - IBOC system performance with AWGN

Purpose: To accurately and precisely characterize the **digital audio** and **data transmission** performance of the IBOC system in the presence of AWGN in both linear and simulated multipath fading channels, both with and without a 1st-adjacent IBOC FM interferer present.

Desired results: Digital audio, data transmission performance versus:

- 1) AWGN, linear channel, no adjacent channel signals;
- 2) AWGN, linear channel, with 1st-adjacent channel interferer;
- 3) AWGN, simulated multipath fading channel, no adjacent channel signals;
- 4) AWGN, simulated multipath fading channel, with 1st-adjacent channel interferer.

Comments:

- For each case, objective data (e.g., BER, FER, etc.) on both digital audio and data transmission paths, and subjective data (e.g., TOA, POF, etc.) on digital audio desired;
- Multiple data points (BER, FER, etc.) should be collected so as to allow for performance versus carrier-to-noise ratio data plots;
- 1st-adjacent channel interference cases performed with upper and lower interferers (individually); suggested D/U ratios are 0, +6 dB, +12 dB, and +18 dB;
- Suggested subjective evaluation procedure: refer to EIA DAR Laboratory test report, August 11, 1995;

- Suggested noise measurement procedure: refer to EIA DAR Laboratory Test Report, August 11, 1995, Appendix S;
- Suggested simulated multipath scenarios: refer to Appendix A.

5.1.3 Test C - IBOC system performance with special impairments

Purpose: To accurately and precisely characterize the **digital audio** and **data transmission** performance of the IBOC system in the presence of the following special channel impairments, both with and without a 1st-adjacent IBOC FM interferer present:

- Impulse noise – simulates automobile environment;
- Susceptibility to narrowband noise;
- Airplane-flutter-type multipath;
- Weak signal – simulates reception failure as distance between transmitter and receiver increases;
- Delay spread/doppler-type multipath with short and long delays, and both slow and fast motion.

Desired results: Digital audio, data transmission performance versus (all cases – linear channel):

- 1) Impulse noise, no adjacent channel interferer;
- 2) Impulse noise, with 1st-adjacent channel interferer;
- 3) Susceptibility to narrowband noise, no adjacent channel interferer;
- 4) Susceptibility to narrowband noise, with 1st-adj. channel interferer;
- 5) Airplane flutter-type multipath, no adjacent channel interferer;
- 6) Airplane flutter-type multipath, with 1st-adjacent channel interferer;
- 7) Weak signal, no adjacent channel interferer;
- 8) Weak signal, with 1st-adjacent channel interferer;
- 9) Delay spread/doppler-type multipath, no adj. channel interferer;
- 10) Delay spread/doppler-type multipath, with 1st-adj. chan. interferer.

- Comments:
- For each case, objective data (e.g., BER, FER, etc.) on both digital audio and data transmission paths, and subjective data (e.g., TOA, POF, etc.) on digital audio desired;
 - Multiple data points (BER, FER, etc.) should be collected so as to allow for performance versus impairment level data plots;
 - 1st-adjacent channel interference cases performed with upper and lower interferers (individually); suggested D/U ratios are 0, +6 dB, +12 dB, and +18 dB;
 - Suggested impulse noise impairment parameters: pulse width - 10 nanoseconds; pulse rise and decay time - 3 to 4 nanoseconds; pulse repetition rate - 100 Hz to 1000 Hz, including 120 Hz;
 - Suggested narrowband noise parameters: signal source – FM signal w/5 kHz deviation modulated with white noise; signal location – from 60 kHz below IBOC digital carriers to 60 kHz above, in 20 kHz increments;
 - Suggested airplane flutter scenarios:
 - 400 Km/h, delay 27.5 usec, attenuation 8 dB;
 - 200 Km/h, delay 18.7 usec, attenuation 6 dB;
 - 100 Km/h, delay 6.8 usec, attenuation 4 dB;
 - Refer to EIA DAR Laboratory Report (August 11, 1995) for suggested delay spread/doppler measurement techniques.

5.1.4 Test D - IBOC “digital-to-digital” compatibility performance

- Purpose: To accurately and precisely characterize the **digital audio** and **data transmission** performance of the IBOC system in the presence of co, 1st-adjacent, and 2nd-adjacent channel IBOC FM interference, in a linear channel. In the 2nd-adjacent case, the effect of a compressing linear amplifier (at the 1 dB compression point) in the RF signal chain should be characterized, as well.
- Desired results: Digital audio, data transmission performance versus (linear channel, except where noted):
- 1) Co-channel interference;
 - 2) Single 1st-adjacent channel interference (upper and lower, individually);
 - 3) Simultaneous upper and lower 1st-adjacent channel interference;
 - 4) Single 2nd-adjacent channel interference (upper and lower, individually);
 - 5) Single 2nd-adjacent channel interference (upper and lower, individually) with 1st-adjacent channel interferer present (upper and lower, individually – 4 cases in all);
 - 6) Simultaneous upper and lower 2nd-adjacent channel interference;
 - 7) Simultaneous upper and lower 2nd-adjacent channel interference with compressing linear amplifier in RF chain (operating at 1 dB compression point).
- Comments:
- For each case, objective data (*e.g.*, BER, FER, etc.) on both digital audio and data transmission paths, and subjective data (*e.g.*, TOA, POF, etc.) on digital audio desired;
 - Multiple data points (BER, FER, etc.) should be collected so as to allow for performance versus D/U ratio data plots;
 - Suggested method for establishing analog benchmark: perform analog FM to analog FM interference tests at same D/U ratios identified for digital TOA and POF and characterize analog performance (contact CEMA Engineering dept. to determine current preferred analog FM receivers);
 - For tests involving two simultaneous interferers, it is suggested that one be set to D/U ratios of 0, +6 dB, +12 dB, +18 dB, while the other then be varied to establish operating points of interest (*e.g.*, TOA, POF, etc.).

5.1.5 Test E - IBOC “digital-to-digital” compatibility performance in a multipath fading channel

- Purpose: To accurately and precisely characterize the **digital audio** and **data transmission** performance of the IBOC system in the presence of co, 1st-adjacent, and 2nd-adjacent channel IBOC FM interference, in a multipath fading channel. In the 2nd-adjacent case, the effect of a compressing linear amplifier (at the 1 dB compression point) in the RF signal chain should be determined, as well.
- Desired results: Refer to Test D for description of desired results – all cases identical except now using multipath fading channel simulations.
- Comments:
- For each case, objective data (*e.g.*, BER, FER, etc.) on both digital audio and data transmission paths, and subjective data (*e.g.*, TOA, POF, etc.) on digital audio desired;
 - Multiple data points (BER, FER, etc.) should be collected so as to allow for performance versus D/U ratio data plots;

- Suggested method for establishing analog benchmark: perform analog FM to analog FM interference tests at same D/U ratios identified for digital TOA and POF and characterize analog performance (contact CEMA Engineering dept. to determine current preferred analog FM receivers);
- For tests involving two simultaneous interferers, it is suggested that one be set to D/U ratios of 0, +6 dB, +12 dB, +18 dB, while the other then be varied to establish operating points of interest (*e.g.*, TOA, POF, etc.);
- Suggested simulated multipath scenarios: refer to Appendix A.

5.1.6 Test F - IBOC “digital-to-analog” compatibility performance

Purpose: To accurately and precisely characterize the ***analog main channel audio*** performance of the IBOC system in the presence of co, 1st-adjacent, and 2nd-adjacent channel IBOC FM interference, as experienced by a representative selection of commercially-available analog FM receivers.

Desired results: Analog main-channel audio performance, objective and subjective, versus (all cases linear channel):

- 1) Co-channel interference;
- 2) Single 1st-adjacent channel interference (upper and lower, individually);
- 3) Simultaneous upper and lower 1st-adjacent channel interference;
- 4) Single 2nd-adjacent channel interference (upper and lower, individually);
- 5) Single 2nd-adjacent channel interference (upper and lower, individually) with 1st-adjacent channel interferer present (upper and lower, individually – 4 cases in all);
- 6) Simultaneous upper and lower 2nd-adjacent channel interference.

Comments:

- Suggested objective characterization: D/U ratio required for main channel stereo audio S/N ratio of 35 dB and 50 dB (quasi-peak measurements);
- Suggested subjective evaluation procedure: refer to EIA DAR Laboratory test report, August 11, 1995;
- Contact CEMA Engineering dept. to determine current preferred analog FM receivers for use in analog compatibility tests;
- For tests involving two simultaneous interferers, it is suggested that one be set to D/U ratios of 0, +6 dB, +12 dB, +18 dB, while the other then be varied to establish operating points of interest (*e.g.*, TOA, POF).

5.1.7 Test G - IBOC “digital-to-analog” compatibility performance in a multipath fading channel

Purpose: To accurately and precisely characterize the ***analog main channel audio*** performance of the IBOC system, in a multipath fading channel, in the presence of co, 1st-adjacent, and 2nd-adjacent channel IBOC FM interference, as experienced by a representative selection of commercially-available analog FM receivers.

Desired results: Refer to Test F for desired results description – all cases identical except now using multipath fading channel simulations.

- Comments:
- Suggested objective characterization: D/U ratio required for main channel stereo audio S/N ratio of 35 dB and 50 dB (quasi-peak measurements);
 - Suggested subjective evaluation procedure: refer to EIA DAR Laboratory test report, August 11, 1995;
 - Contact CEMA Engineering dept. to determine current preferred analog FM receivers for use in analog compatibility tests;
 - Suggested simulated multipath scenarios: refer to Appendix A.
 - For tests involving two simultaneous interferers, it is suggested that one be set to D/U ratios of 0, +6 dB, +12 dB, +18 dB, while the other then be varied to establish operating points of interest (e.g., TOA, POF).

5.1.8 Test H - IBOC “analog-to-digital” compatibility performance

- Purpose: To accurately and precisely characterize the **digital audio** and **data transmission** performance of the IBOC system in the presence of 1st-adjacent, and 2nd-adjacent channel standard FM analog (i.e. non-IBOC FM) interference.
- Desired results: Digital audio, data transmission performance versus (all cases - linear channel):
- 1) Single 1st-adjacent channel interference (upper and lower, individually);
 - 2) Simultaneous upper and lower 1st-adjacent channel interference;
 - 3) Single 2nd-adjacent channel interference (upper and lower, individually).
- Comments:
- For each case, objective data (e.g., BER, FER, etc.) on both digital audio and data transmission paths, and subjective data (e.g., TOA, POF, etc.) on digital audio desired;
 - Multiple data points (BER, FER, etc.) should be collected so as to allow for performance versus D/U ratio data plots;
 - For tests involving two simultaneous interferers, it is suggested that one be set to D/U ratios of 0, +6 dB, +12 dB, +18 dB, while the other then be varied to establish operating points of interest (e.g., TOA, POF).

5.1.9 Test I - IBOC “analog-to-digital” compatibility performance in a multipath fading channel

- Purpose: To accurately and precisely characterize the **digital audio** and **data transmission** performance of the IBOC system in the presence of 1st-adjacent, and 2nd-adjacent channel standard FM analog (i.e. non-IBOC FM) interference, in a multipath fading channel.
- Desired results: Refer to Test H for description of desired results – all cases identical except now using multipath fading channel simulations. Also include additional test 4):
- 4) Simultaneous upper and lower 2nd-adjacent channel interference.
- Comments:
- For each case, objective data (e.g., BER, FER, etc.) on both digital audio and data transmission paths, and subjective data (e.g., TOA, POF, etc.) on digital audio desired;
 - Multiple data points (BER, FER, etc.) should be collected so as to allow for performance versus carrier-to-noise ratio data plots;

- For tests involving two simultaneous interferers, it is suggested that one be set to D/U ratios of 0, +6 dB, +12 dB, +18 dB, while the other then be varied to establish operating points of interest (*e.g.*, TOA, POF);
- Suggested simulated multipath scenarios: refer to Appendix A.

5.1.10 Test J - IBOC acquisition/reacquisition performance

Purpose: To accurately and precisely characterize the **acquisition/re-acquisition** performance of the IBOC system under weak signal conditions, in both linear and multipath fading channels, and in the presence of 1st-adjacent channel IBOC FM interference.

Desired results: IBOC system acquisition/re-acquisition performance versus:

- 1) Short interruption in signal (linear channel, no noise);
- 2) Long interruption in signal (linear channel, no noise);
- 3) Short interruption in signal (linear channel, with AWGN);
- 4) Long interruption in signal (linear channel, with AWGN);
- 5) Short interruption in signal (linear channel, no noise), with 1st-adjacent channel interference;
- 6) Long interruption in signal (linear channel, no noise), with 1st-adjacent channel interference;
- 7) Short interruption in signal (multipath fading channel, no noise);
- 8) Long interruption in signal (multipath fading channel, no noise);
- 9) Short interruption in signal (multipath fading channel, with AWGN);
- 10) Long interruption in signal (multipath fading channel, with AWGN);
- 11) Short interruption in signal (multipath fading channel, no noise), with 1st-adjacent channel interference;
- 12) Long interruption in signal (multipath fading channel, no noise), with 1st-adjacent channel interference;

Comments:

- Interruptions (short and long) must cause receiver to lose lock;
- Data points should be collected at a number of AWGN noise levels (as appropriate) to allow for performance versus carrier-to-noise ratio data plots;
- 1st-adjacent channel interference cases performed with upper and lower interferers (individually); suggested D/U ratios are 0, +6 dB, +12 dB, and +18 dB;
- Suggested simulated multipath scenarios: refer to Appendix A.

5.1.11 Test K – DAB quality

Purpose: To subjectively establish the unimpaired audio quality of the IBOC digital audio signal through a linear channel, and compare that performance to existing analog FM unimpaired audio quality.

Desired results:

- 1) Subjective evaluation report comparing IBOC digital audio quality (unimpaired, linear channel) with existing analog FM quality (unimpaired, linear channel);
- 2) "Long form" audio DAT recording through IBOC system (as described in Section 4.2).

- Comments:
- Recommended source and reference audio material: NRSC source and broadcast chain reference (refer to Section 4 for additional information);
 - Refer to Appendix A for suggested audio test segments;
 - DAT recordings used in subjective evaluations should also be included in submission to allow for review by NRSC.

5.1.12 Test L - IBOC “digital-to-host analog” compatibility performance

Purpose: To accurately and precisely characterize the **host analog main channel audio** and **host subcarrier** performance of the IBOC system in the presence of the IBOC digital signal, in both linear and multipath fading channels, as experienced by a representative selection of commercially-available analog FM and subcarrier receivers. Of particular interest is the effect of IBOC DAB on 92 kHz analog subcarrier signals, which are used extensively by public broadcasting stations in support of reading services for the blind.

Desired results: Host analog main-channel audio performance, objective and subjective, versus:

- 1) Presence or absence of IBOC digital signal energy, linear channel;
- 2) Presence or absence of IBOC digital signal energy, multipath fading channel.

Host subcarrier audio or data performance (as appropriate) versus:

- 3) Presence or absence of IBOC digital signal energy, linear channel;
- 4) Presence or absence of IBOC digital signal energy, multipath fading channel.

- Comments:
- Contact CEMA Engineering dept. to determine current preferred analog FM receivers for use in analog compatibility tests;
 - Suggested objective characterization: D/U ratio required for main channel stereo audio S/N ratio of 35 dB and 50 dB (quasi-peak measurements);
 - Suggested subjective evaluation procedure: refer to EIA DAR Laboratory test report, August 11, 1995;
 - Suggested FM subcarrier configuration: 3% RDS (57 kHz c.f.), 8.5% 67 kHz c.f. FM analog, and 8.5% 92 kHz c.f. FM analog.

5.1.13 Test M - IBOC “host analog-to-digital” compatibility performance

Purpose: To accurately and precisely characterize the **digital audio** and **data transmission** performance of the IBOC system in the presence of the host analog signal, in both linear and multipath fading channels.

Desired results: Digital audio, data transmission performance versus:

- 1) Percent modulation of the analog host signal, linear channel;
- 2) Percent modulation of the analog host signal, multipath fading channel.

- Comments:
- For each case, objective data (e.g., BER, FER, etc.) on both digital audio and data transmission paths, and subjective data (e.g., TOA, POF, etc.) on digital audio desired;
 - Multiple data points (BER, FER, etc.) should be collected so as to allow for performance versus percent modulation data plots;
 - Suggested FM subcarrier configuration (for analog host signal): 3% RDS (57 kHz c.f.), 8.5% 67 kHz c.f. FM analog, and 8.5% 92 kHz c.f. FM analog;

- Suggested subjective evaluation procedure: refer to EIA DAR Laboratory test report, August 11, 1995.

5.2 AM-band portion

5.2.1 Test A - System Calibration

Purpose: To constantly maintain IBOC system hardware and associated test equipment in a known, calibrated state, and to establish clear and complete documentation of that state.

Desired results:

- 1) Average and peak RF power measurements of IBOC signal;
- 2) RF spectrum plot showing shape and spectral occupancy of IBOC signal;
- 3) Digital audio subjective performance baseline—using “Threshold of Audibility” (TOA) or some other subjective criteria—versus AWGN (linear channel);
- 4) Baseline characterization of system digital performance (BER, FER, or other similar parameter) versus AWGN (linear channel);
- 5) Analog proof-of-performance test results (frequency response, distortion characteristics of main channel audio, etc.);
- 6) Calibration record of equipment used for testing.

Comments:

- Systems should be calibrated regularly to insure precise and accurate test data;
- Suggested settings for RF spectrum plots – in accordance with FCC rules, §73.44;
- Multiple data points (BER, FER, etc.) should be collected so as to allow for performance versus carrier-to-noise ratio data plots;
- Calibration records should be signed and dated.

5.2.2 Test B - IBOC system performance with AWGN

Purpose: To accurately and precisely characterize the **digital audio** and **data transmission** performance of the IBOC system in the presence of AWGN in a linear channel.

Desired results: Digital audio, data transmission performance versus:

- 1) AWGN, linear channel.

Comments:

- For each case, objective data (e.g., BER, FER, etc.) on both digital audio and data transmission paths, and subjective data (e.g., TOA, POF, etc.) on digital audio desired;
- Multiple data points (BER, FER, etc.) should be collected so as to allow for performance versus carrier-to-noise ratio data plots;
- Suggested subjective evaluation procedure: refer to EIA DAR Laboratory test report, August 11, 1995;
- Suggested noise measurement procedure: refer to EIA DAR Laboratory Test Report, August 11, 1995, Appendix S.

5.2.3 Test C - IBOC system performance with special impairments

Purpose: To accurately and precisely characterize the **digital audio** and **data transmission** performance of the IBOC system in the presence of the following special channel impairments:

- Impulse noise – simulates automobile environment;
- Weak signal – simulates reception failure as distance between transmitter and receiver increases.

Desired results: Digital audio, data transmission performance versus (all cases – linear channel):

- 1) Impulse noise;
- 2) Weak signal.

- Comments:
- For each case, objective data (e.g., BER, FER, etc.) on both digital audio and data transmission paths, and subjective data (e.g., TOA, POF, etc.) on digital audio desired;
 - Multiple data points (BER, FER, etc.) should be collected so as to allow for performance versus impairment level data plots;
 - Suggested impulse noise impairment parameters: pulse width - 100 nanoseconds; pulse rise and decay time - 3 to 4 nanoseconds; pulse repetition rate - 100 Hz to 1000 Hz , including 120 Hz.

5.2.4 Test D - IBOC “digital-to-digital” compatibility performance

Purpose: To accurately and precisely characterize the **digital audio** and **data transmission** performance of the IBOC system in the presence of co, 1st-adjacent, 2nd-adjacent, and 3rd-adjacent channel IBOC AM interference, in a linear channel.

Desired results: Digital audio, data transmission performance versus (linear channel, except where noted):

- 1) Co-channel interference;
- 2) Single 1st-adjacent channel interference (upper and lower, individually);
- 3) Simultaneous upper and lower 1st-adjacent channel interference;
- 4) Single 2nd-adjacent channel interference (upper and lower, individually);
- 5) Simultaneous upper and lower 2nd-adjacent channel interference;
- 6) Single 3rd-adjacent channel interference (upper and lower, individually);

- Comments:
- For each case, objective data (e.g., BER, FER, etc.) on both digital audio and data transmission paths, and subjective data (e.g., TOA, POF, etc.) on digital audio desired;
 - Multiple data points (BER, FER, etc.) should be collected so as to allow for performance versus D/U ratio data plots;
 - For tests involving two simultaneous interferers, it is suggested that one be set to D/U ratios of 0, +6 dB, +12 dB, +18 dB, while the other then be varied to establish operating points of interest (e.g., TOA, POF, etc.).

5.2.5 Test F - IBOC “digital-to-analog” compatibility performance

Purpose: To accurately and precisely characterize the **analog main channel audio** performance of the IBOC system in the presence of co, 1st-adjacent, and 2nd-adjacent channel IBOC AM interference, as experienced by a representative selection of commercially-available analog AM receivers.

Desired results: Analog main-channel audio performance, objective and subjective, versus (all cases linear channel):

- 1) Co-channel interference;
- 2) Single 1st-adjacent channel interference (upper and lower, individually);
- 3) Single 2nd-adjacent channel interference (upper and lower, individually).

- Comments:
- Suggested objective characterization: D/U ratio required for main channel stereo audio S/N ratio of 25 dB and 40 dB (quasi-peak measurements);
 - Suggested subjective evaluation procedure: refer to EIA DAR Laboratory test report, August 11, 1995;
 - Contact CEMA Engineering dept. to determine current preferred analog AM receivers for use in analog compatibility tests.

5.2.6 Test H - IBOC “analog-to-digital” compatibility performance

Purpose: To accurately and precisely characterize the **digital audio** and **data transmission** performance of the IBOC system in the presence of co-channel, 1st-adjacent, and 2nd-adjacent channel standard AM analog (i.e. non-IBOC FM) interference.

Desired results: Digital audio, data transmission performance versus (all cases - linear channel):

- 1) Co-channel interference;
- 2) Single 1st-adjacent channel interference (upper and lower, individually);
- 3) Simultaneous upper and lower 1st-adjacent channel interference;
- 4) Single 2nd-adjacent channel interference (upper and lower, individually);
- 5) Simultaneous upper and lower 2nd-adjacent channel interference.

- Comments:
- For each case, objective data (e.g., BER, FER, etc.) on both digital audio and data transmission paths, and subjective data (e.g., TOA, POF, etc.) on digital audio desired;
 - Multiple data points (BER, FER, etc.) should be collected so as to allow for performance versus D/U ratio data plots;
 - For tests involving two simultaneous interferers, it is suggested that one be set to D/U ratios of 0, +6 dB, +12 dB, +18 dB, while the other then be varied to establish operating points of interest (e.g., TOA, POF).

5.2.7 Test J - IBOC acquisition/reacquisition performance

Purpose: To accurately and precisely characterize the **acquisition/re-acquisition** performance of the IBOC system under weak signal conditions, in a linear channel.

Desired results: IBOC system acquisition/re-acquisition performance versus:

- 1) Short interruption in signal (linear channel, no noise);
- 2) Long interruption in signal (linear channel, no noise);
- 3) Short interruption in signal (linear channel, with AWGN);
- 4) Long interruption in signal (linear channel, with AWGN).

- Comments:
- Interruptions (short and long) must cause receiver to lose lock;
 - Data points should be collected at a number of AWGN noise levels (as appropriate) to allow for performance versus carrier-to-noise ratio data plots.

5.2.8 Test K – DAB quality

- Purpose: To subjectively establish the unimpaired audio quality of the IBOC digital audio signal through a linear channel, and compare that performance to existing analog AM unimpaired audio quality (and possibly FM audio quality as well).
- Desired results:
- 1) Subjective evaluation report comparing IBOC digital audio quality (unimpaired, linear channel) with existing analog AM quality (unimpaired, linear channel). Optionally, perform and report upon comparison of AM IBOC digital audio quality with FM analog audio quality;
 - 2) “Long form” audio DAT recording through IBOC system (as described in Section 4.2).
- Comments:
- Recommended source and reference audio material: NRSC source and broadcast chain reference (refer to Section 4 for additional information);
 - Refer to Appendix B for suggested audio test segments;
 - DAT recordings used in subjective evaluations should also be included in submission to allow for review by NRSC.

5.2.9 Test L - IBOC “digital-to-host analog” compatibility performance

- Purpose: To accurately and precisely characterize the **host analog main channel audio** performance of the IBOC system in the presence of the IBOC digital signal, in a linear channel, as experienced by a representative selection of commercially-available analog AM receivers.
- Desired results: Host analog main-channel audio performance, objective and subjective, versus:
- 1) Presence or absence of IBOC digital signal energy, linear channel.
- Comments:
- Contact CEMA Engineering dept. to determine current preferred analog AM receivers for use in analog compatibility tests;
 - Suggested subjective evaluation procedure: refer to EIA DAR Laboratory test report, August 11, 1995.

5.2.10 Test M - IBOC “host analog-to-digital” compatibility performance

- Purpose: To accurately and precisely characterize the **digital audio** and **data transmission** performance of the IBOC system in the presence of the host analog signal, in a linear channel.
- Desired results: Digital audio, data transmission performance versus:
- 1) Percent modulation of the analog host signal, linear channel.
- Comments:
- For each case, objective data (e.g., BER, FER, etc.) on both digital audio and data transmission paths, and subjective data (e.g., TOA, POF, etc.) on digital audio desired;
 - Multiple data points (BER, FER, etc.) should be collected so as to allow for performance versus percent modulation data plots;
 - Suggested subjective evaluation procedure: refer to EIA DAR Laboratory test report, August 11, 1995.

Appendix A. Recommended Lab Test Outline – FM-band

REVISION #13 October 8, 1998					
IBOC LABORATORY TEST GUIDELINES-FM BAND					
Test Group	Test & Impairment	TEST PROCEDURE Note: The audio impairment test material will be used for the TOA test (see test K).	Type of Evaluation	Signal Level	Test Results Data to be Recorded
A Calibration	1 Power (each test day or as needed)	1. IBOC analog and digital power will be read separately. 2. The digital average and peak power will be measured for each system at least once.	Objective	NA	Power level (average and peak)
	2 Spectrum (each test day or as needed)	1. A spectrum analyzer plot of the system RF spectrum will be taken for each test. 2. The spectrum analyzer settings will be: RES BW 1 kHz, VBW 30 Hz, and sweep span 500 kHz.	Objective	M	Spectrum plot
	3 TOA (daily or as needed)	Gaussian noise will be added to the signal in 0.25 dB steps until TOA occurs. Test C-4, weak signal, will also be conducted. For the FM systems that use diversity (two digital and FM), the TOA level will be found separately for each of the digital channels. Setting the composite level at -70 dBm, the analog S/N and stereo separation will be measured.	EO&C and Objective	M	TOA level (all)
	4 Audio recording (as needed)	An audio recording will be made of all of the proponent audio channels (analog and digital).	EO&C	M & W	Digital audio recording for the test record
	5 Proof IBOC (weekly)	During the analog compatibility tests, a proof of performance test will be conducted weekly on the analog portion of the proponent IBOC systems. A high quality demodulator will be used for this test.	Objective	Varying	Record of frequency response, separation, and distortion for the test record
	6 Reference analog TX total proof	If a reference transmitter is used, a proof of performance test will be conducted on this transmitter, with and without subcarriers, prior to the compatibility tests. Both subcarrier groups will be calibrated.	Objective	NA	Test records
	7 Monitor calibration (weekly or as needed)	The analog modulation monitors will be calibrated weekly using Bessel nulls.	Objective	NA	Calibration results recorded in laboratory test record
	8 Test bed calibration (monthly)	All of the critical components in the test bed, including the multipath simulator, attenuators, combiners, filters, generators, and measuring instruments, will be calibrated on a monthly schedule.	Objective	NA	Calibration record in test record

Composite Signal Levels: Wweak -77 dBm
 Moderate -62 dBm
 Strong -47 dBm

REVISION #13 October 8, 1998		IBOC LABORATORY TEST GUIDELINES-FM BAND			
Test Group	Test & Impairment	TEST PROCEDURE	Type of Evaluation	Signal Level dBm	Test Results Data to be Recorded
		<p>Note:</p> <ol style="list-style-type: none"> The EBU SQAM CD Glockenspiel audio segment will be used for impairment test. The detailed procedure for noise measurements will be supplied. See Appendix S of the Digital Audio Radio Laboratory Tests Report, August 11, 1995 Clipped pink noise will be used for the host analog signal. The EIA DAR laboratory tests were conducted with nine desired signal paths (rays) and three undesired paths as specified in Appendix E (VHF RAYLEIGH 9 PATH SIMULATION) of the August 11, 1995 report. When using a single six-channel MP simulator, only the desired channel will be effected by multipath. The six strongest paths will be selected from the nine for the six-path simulation. 			
B Impairment tests for characterization of DAR signal failure	1. Noise	<ol style="list-style-type: none"> Gaussian noise will be increased to TOA & POF (0.25 dB steps) and the levels logged. From the TOA the noise will be increased in 0.5 dB steps until the noise is 0.5 dB beyond POF. For each 0.5 dB step a digitally recording will be made for expert subjective assessment. Steps #1 & #2 will be repeated for each of the three impairment audio segments. The noise test will be repeated with an individual first adjacent upper and lower undesired analog FM signal. The first adjacent D/U will be set for +18 dB, +12 dB, +6 dB, and 0 dB. The undesired modulation will be processed program material. 	EO&C	M	Noise level at TOA & POF for all tested modes
	2. Multipath with noise	<ol style="list-style-type: none"> This test will be conducted four times, each with different Rayleigh multipath scenarios. <i>The</i> multipath scenarios will be those specified by the channel characterization sub-group of the DAR subcommittee. The RF level at the output of the MP simulator will be adjusted to compensate for variations in average signal level for each scenario. Without noise added to the composite IBOC signal, each of the multipath signal scenarios will be assessed in the transmission laboratory for impairments. For those systems where no impairment is heard, noise will be added to the signal in 0.5dB steps until the TOA and POF are found. For those systems where impairments are heard, the RF level will be increased in 1 dB steps until the audio impairments have ceased or the level has been increased by 10 dB. For those systems that require noise to be added to hear multipath, seven digital audio recordings will be made at the following noise levels: 1 dB below TOA, 0.5 dB below TOA, 0.5 dB above TOA, at six equal points between TOA and POF, and at POF. These digital recordings are for expert subjective assessment. The recordings will be made at both signal levels. 	EO&C	M +	TOA & POF with multipath and noise for all test modes
	3. Multipath for diversity systems	<ol style="list-style-type: none"> For the systems that use digital diversity (systems with two complete digital signals extending into the first adjacent FM channel), the multipath tests will be repeated with an individual interfering FM signal on the upper and lower first adjacent channel. The D/U ratios will be set for +18 dB, +12 dB, +6 dB, and 0 dB. The first adjacent modulation will be processed audio (committee make recommendation). The test will be repeated with the impairment audio on the analog channel. 	EO&C	M +	MP performance of each digital signal and test mode

REVISION #13 October 8, 1998		IBOC LABORATORY TEST GUIDELINES-FM BAND			
Test & Impairment	TEST PROCEDURE Notes:	Type of Evaluation	Sig. Level	Test Results Data to be Recorded	
C DAR with special impairment	<p>1. The EBU SQAM CD Glockenspiel audio segment will be used for the impairment tests.</p> <p>2. The host analog modulation will be clipped pink noise.</p> <p>3. Test C will be repeated with an individual upper and lower first adjacent undesired signal. The D/U ratios will be set for +18 dB, +12 dB, +6 dB, and 0 dB. The first adjacent modulation will be processed audio (The ABBA cut from the EBU SQAM test CD).</p>				
	<p>1. A generator capable of generating 10 nanosecond wide pulses with a rise and decay time of 3 to 4 nanoseconds will be used for the test. Pulse rates between 100 Hz to 1000 Hz will be used. All systems will be tested with a 120 Hz signal.</p> <p>2. The pulse generator output will be mixed with the DAR signal.</p> <p>3. The amplitude of the pulses will be increased until the laboratory specialist hears the TOA.</p>	EO&C	M	Pulse amplitude in Volts P-P at TOA	
	<p>1. The undesired signal will be generated with a laboratory test signal generator, FM modulated (deviation 5 kHz) with noise.</p> <p>2. The undesired signal will be incremented at 20 kHz intervals from 60 kHz below the digital signal to 60 kHz above the signal.</p> <p>3. Starting at a low RF level, the undesired amplitude will be increased in 1 dB steps until the TOA is heard.</p>	EO&C	M	Variations in the sensitivity to noise at different frequencies in the digital channel.	
	<p>1. Tests will be conducted with two simulated aircraft speeds of less than 400 Km/h.</p> <p>2. The simulated reflected signal will be increased until the TOA or POF is heard by the lab specialist.</p> <p>3. Scenarios:</p> <ul style="list-style-type: none"> a. 400 Km/h, delay 27.5 usec, attenuation 8 dB b. 200 Km/h, delay 18.7 usec, attenuation 6 dB c. 100 Km/h, delay 6.8 usec, attenuation 4 dB 	EO&C	M	Multipath parameters at TOA & POF	
	<p>1. Starting with a medium signal level, the signal will be reduced to TOA & POF (0.25 dB steps).</p> <p>2. A single audio impairment recording will be used for this test.</p> <p>3. Characterize failure between TOA and POF in 0.5 dB steps.</p> <p>Note- weak signal test should be used to monitor the performance of the receiver hardware but should not be used to evaluate the proposed system.</p>	EO&C	Varying	Signal level at TOA & POF TOA to POF characterization	
5 Delay spread/doppler	<p>Systems will be tested with four simulated multipath and motion extremes:</p> <ul style="list-style-type: none"> 1. Flat or short multipath with slow and fast motion. 2. Long multipath with slow and fast motion. <p>Note: See DAR laboratory report August 11, 1995 for procedures.</p>	EO&C	M	Rated impairments with varying delay spreads and doppler	

REVISION #13 October 8, 1998		IBOC LABORATORY TEST GUIDELINES-FM BAND			
Test Group	Test Number and Impairment	TEST PROCEDURE Note: 1. Two additional IBOC transmitters supplied by each proponent will generate the undesired DAR signals. 2. The desired host analog signal will be modulated with clipped pink noise. 3. A single impairment audio will be used for these tests.	Type of Evaluation	Sig. Level	Test Results & Data to be Recorded
D DAR -> DAR	1 Co-channel	1. The undesired co-channel DAR signal will be increased until the TOA and POF are heard by the lab specialist (0.25 dB resolution). 2. Co-channel signal failure will be characterized in 0.25 dB steps from TOA to POF using the five-step CCIR impairment scale. 3. Using the TOA D/U parameters found in step #1, FM to FM interference tests will be conducted to establish the analog reference. EO&C comments comparing the FM performance with the digital will be made. All five receives used for the EIA DAR test will be used for the analog reference tests.	EO&C in Lab	M	D/U & levels at TOA & POF Co-channel failure characteristics
	2 Single first adjacent	1. The undesired lower first adjacent composite IBOC signal will be increased in 0.5 dB steps until the TOE and POF are found. If when a D/U of 6 dB is reached and no TOA is found, band pass filtered Gaussian noise will be added to the signal until TOA and POF are found. The level of the added noise will be recorded. 2. With an undesired upper first adjacent standard FM signal set to D/Us of 18.0 dB, 12.0 dB, 6.0 dB, and 0.0 dB, the undesired first lower adjacent signal will be increased in 0.5 dB steps until the TOA and POF are found. 3. The test will be repeated (steps 1 and 2) with an upper first adjacent undesired signal.	EO&C in Lab	W&M	D/U & levels at TOA & POF First adjacent failure characteristics
	3 Second adjacent	1. Steps 2 through 5 will be conducted with a minimum out-of-channel power. 2. The undesired lower second adjacent DAR signal will be increased in 0.5 dB steps until the TOA and POF are observed. 3. The above test will be repeated with an upper <u>first</u> adjacent analog signal set for a D/U of +18 dB, +12dB, +6 dB and 0 dB. 4. The test will be repeated (steps 2 and 3) with an upper second adjacent undesired signal. 5. Simultaneous upper and lower second adjacent tests will be conducted. 6. The second adjacent tests will be repeated with the undesired signal's out-of-channel power increased in 5 dB steps until TOA and POF are detected in the desired IBOC audio. 7. The tests will be conducted with a D/U of at least -40 dB.	EO&C in Lab	W&M	D/U & levels at TOA & POF Second adjacent D/U with and without out-of-band components

REVISION #13 October 8, 1998		IBOC LABORATORY TEST GUIDELINES – FM BAND			
Test Group	Test Number and Impairment	TEST PROCEDURE	Type of Evaluated	Sig. Level	Test Results & Data to be Recorded
		Note: 1. The desired DAB signal will be modulated with the unprocessed impairment test audio sequences. 2. Clipped pink noise will be used for the host analog modulation.			
E DAR -> DAR with multipath	1 Co-channel	1. This test will be conducted four times, each with different multipath scenarios specified by the DAR subcommittee. 2. Without the undesired signal added, the transmission laboratory specialist will observe each of the multipath scenarios. 3. If impairments are heard no further testing will be conducted. 4. For those multipath tests where no impairment are heard, the undesired interference will be increased to the signal until TOA and POF interference levels are heard. 5. The D/U at TOA and POF will be recorded in the laboratory log. 6. Using the TOA D/U parameters found in step #5, FM to FM interference tests will be conducted to establish the analog reference. EO&C comments comparing the FM performance with the digital will be made. The Delco & Ford receivers used for the EIA DAR test will be used for the analog reference tests.	EO&C in Lab	M	D/U at TOA and POF levels for each undesired signal and multipath scenarios
	2 First adjacent	Same as Co-channel Test, E-1. 1. This test will be conducted on both the upper and lower first adjacent channels. 2. The test will be repeated with simultaneous upper and lower first adjacent undesired signals.	EO&C in Lab	W&M	D/U at TOA and POF levels for each undesired signal and multipath scenarios Audio recordings
	3 Second adjacent	Same as Co-channel Test, E-1. 1. This test will be conducted on both the upper and lower second adjacent channels. 2. The test will be repeated with simultaneous upper and lower second adjacent undesired signals.	EO&C in Lab	W&M	D/U at TOA and POF levels for each undesired signal and multipath scenarios Audio recordings

REVISION #13 October 8, 1998		IBOC LABORATORY TEST GUIDELINES - FM BAND			
Test Group	Test & Impairment	TEST PROCEDURE	Type of Evaluation	Desired Signal Level	Test Results Data to be Recorded
		Notes: 1. These tests will compare the IBOC to analog with the analog to analog interference. 2. If the proponent systems maintain digital signals that are more than 114 kHz from the host FM channel center frequency, further co-channel tests are unnecessary. The IBOC host FM signal will be the predominate interferer to the co-channel FM tests.			
F	<u>1 Co-channel objective</u>	See note 2 above	NA	NA	
DAR -> Analog (interference to an analog receiver with no other impairments)	<u>2 1st adjacent</u>	1. The five FM stereo receivers characterized in test L will be used for the FM band tests. 2. The desired FM transmitters will be set for 75 kHz deviation. The signal will be modulated with pilot. 3. The CCIR recommendation 412-4 weighting filter will be used for the program channel S/N measurements. A 19 kHz LP pilot filter will be used for the noise tests. 4. Increasing the undesired signal until the resulting audio signal/noise ratios are 35 and 50 dB (QPK), the D/U will be measured for the interference combinations: analog -> analog, and the DAR -> analog.	Objective	M	D/U at specified S/N for A -> A and D -> A
	<u>3 2nd adjacent</u>	1. The second adjacent channel tests are the same as the first-adjacent tests. The first and second adjacent channel measurement will be made both above and below the desired signal frequency.	Objective	M	D/U at specified S/N for A -> A and D -> A
	<u>4 Co-channel</u>	<i>See note 2 above.</i>	NA	NA	
	<u>5 1st adjacent</u>	1. The receivers used in step F.2.1 will be used for the subjective tests. 2. This test will be conducted with +16 dB, +6 dB, and 0 D/U. 3. Classical music, rock music, and silence will be used for the desired channel analog audio. 4. The reference will be analog to analog interference at 6 dB D/U. 5. The reference and the test will be recorded on digital tape for demonstration or evaluation.	Subjective EO&C	M	Recordings for industry evaluation
	<u>6 2nd adjacent</u>	1. Same as first adjacent Test F.5, with the second adjacent D/U set at -20 dB and -40 dB.	Subjective EO&C	M	Recordings for industry evaluation

REVISION #13 October 8, 1998		IBOC LABORATORY TEST GUIDELINES-FM BAND			
Test Group	Test	Test Description	Type of Eval.	Desired Signal Level	Test Results & Data to be Recorded
		Notes: 1. The undesired DAR audio signals will be processed rock music.			
G DAR -> analog with multipath Interference to an analog receiver with multipath on the desired and undesired signals	1 Co-channel Subjective	See F-1	Subjective & EO&C	M	NA
	2 First Adjacent	1. This test will be conducted using the urban slow and urban fast multipath scenarios. The scenarios are those specified by the DAR subcommittee. 2. The five FM stereo receivers used in test L will be used. 3. The desired audio signal will be a moderately processed FM stereo signal. 4. The desired programming will be classical music, silence, and spoken voice. 5. The desired FM channel will be set for 75 kHz deviation with 1 kHz tone, pilot, and subcarriers (SC group A). 6. The FM band tests will subjectively evaluate the difference between the analog -> analog for reference and DAR -> analog set at a 6 dB D/U. 7. This test will be digitally recorded for further evaluation. Note: The first and second adjacent channel measurements will be made above and below the desired signal and averaged.	Subjective & EO&C	M	EO&C and subjective evaluation with the first adjacent 6 dB D/U.
	3 Second Adjacent	The second adjacent tests are the same as the first adjacent test G-2 with a -40 dB D/U in G2.6.	Subjective & EO&C	M	EO&C and subjective evaluation with -40 dB D/U.

REVISION #13 October 8, 1998		IBOC LABORATORY TESTS GUIDELINES - FM BAND			
Test Group	Test & Impairment	TEST PROCEDURE	Type of Evaluation	Desired Signal Level	Test Results Data to be Recorded
		Note: 1. The undesired analog signal will be modulated with processed rock stereo. 2. The host analog will be modulated with clipped pink noise.			
H	<u>1 Co-channel</u>	The host analog to digital test should provide all the data for co-channel performance.	NA	NA	
Analog -> DAR (no other impairments)	<u>2 1st adjacent</u>	1.The undesired lower 1st adjacent analog standard FM signal will be increased in 0.5 dB steps until the TOA and POF are found. If when a D/U of 6 dB is reached no impairments are heard, band pass filtered Gaussian noise will be added to the signals until TOA and POF are found. The level of the added noise will be recorded. 2.With an undesired upper 1st adjacent standard FM signal set to D/Us of +18.0, +12.0, + 6.0, and 0.0 dB, the undesired 1st lower adjacent signal will be increased in 0.5 dB steps until the TOA and POF are found. 3.This test will be repeated (steps 1 and 2) with an upper 1st adjacent undesired signal.	EO&C in lab	M	D/U at TOA & POF. Or Performance with 1st adjacent interference
	<u>3 Simultaneous upper and lower 1st adjacent</u>	1.Simultaneous upper and lower 1st adjacent analog signals will be increased until the TOA and POF are heard (0.5 dB steps).	EO&C in lab	M	D/U at TOA & POF.
	<u>4 2nd adjacent</u>	Note – this test will be conducted on both upper and lower 2nd adjacent channels. 1. The undesired analog signal will be increased until the TOA and POF are observed (1.0 dB steps). 2. Simultaneous upper and lower second adjacent tests will be conducted. The test will be conducted with a D/U of at least –40 dB.	EO&C in lab	M	D/U at TOA & POF

REVISION #13 October 8, 1998		IBOC LABORATORY TEST GUIDELINES-FM BAND			
Test Number and Impairment	TEST PROCEDURE	Type of Evaluation	Sig. Level	Test Results & Data to be Recorded	
	<p>Note:</p> <ol style="list-style-type: none"> The FM signal will be modulated with processed rock stereo and subcarrier group A. The DAB signal will be modulated with the impairment test audio. The host FM signal will be modulated with clipped pink noise. If clipped pink noise is heard during any of these tests, the test will be repeated with the impairment audio simultaneously modulating the digital and host analog channels. These tests will be conducted with the urban slow and urban fast multipath scenarios. The multipath scenarios will be those specified by the channel characterization sub-group of the DAR subcommittee. The RF level at the output of the MP simulator will be adjusted to compensate for variations in average signal level. Both the desired and undesired signals will be modulated with simulated multipath. 				
I Analog -> DAR with multipath	1 Co-channel MP	1. The host analog to digital test (M-2) should provide the data needed for co-channel performance.	NA	NA	NA
	2 First adjacent with multipath	<ol style="list-style-type: none"> The undesired signal will be increased to TOA and POF for both multipath scenarios (0.5 dB steps). For the systems that use diversity digital channels, the TOA may not be heard. In these cases the D/U will be set at 6 dB and a digital audio recording made of the IBOC received signal with each multipath scenario. This test will be conducted on both upper and lower first adjacent channels. 	EO&C in lab	M	D/U at TOA & POF with multipath Audio assessment without TOA.
	3 Simultaneous upper and lower first adjacent with multipath	<ol style="list-style-type: none"> Both the undesired signals will be increased to TOA and POF levels found with both multipath scenarios (0.5 dB steps). For the systems that use diversity digital channels, the TOA may not be heard. In these cases the D/U will be set at +6 dB and a digital audio recording made of the IBOC received signal for each multipath scenario. 	EO&C in lab	M	Same as I-2
	4 Second adjacent with multipath	<ol style="list-style-type: none"> The undesired signals will be increased to TOA and POF for both multipath scenarios (0.5 dB steps). For the systems that use diversity digital channels, the TOA may not be heard. In these cases the D/U will be set at -40 dB and a digital audio recording made of the IBOC received signal with each multipath scenario. This test will be conducted on both upper and lower first adjacent channels. 	EO&C in lab	M	Same as I-2
	5 Simultaneous upper and lower second adjacent with multipath	<ol style="list-style-type: none"> Both the undesired signals will be increased to TOA and POF levels found with both multipath scenarios (0.5 dB steps). For the systems that use diversity digital channels, the TOA may not be heard. In these cases the D/U will be set at -40 dB and a digital audio recording made of the IBOC received signal with each multipath scenario 	EO&C in lab	M	Same as I-2

REVISION #13 October 8, 1998		IBOC LABORATORY TEST GUIDELINES – FM BAND			
Test Group	Test & Impairment	TEST PROCEDURE	Type of Evaluation	Desired Signal Level	Test Results Data to be Recorded
		<p>Note:</p> <ol style="list-style-type: none"> The impairment audio will be Mozart track 67 on the SQAM disk. The host analog channel will be modulated with clipped pink noise. If clipped pink noise is heard during the test, the test will be repeated with the impairment audio simultaneously transmitted on the digital and host analog channels. Each test will be repeated at least five times and the results averaged. 			
J DAR acquisition and reacquisition tests	<u>1 Simulated weak signal failure and acquisition</u>	<ol style="list-style-type: none"> Noise will be added to the signal in 0.25 dB steps until POF is found. The POF level will be recorded. The DAR transmitter will be disconnected from the receiver for one (1) second to assure loss of lock. The test will be repeated with the transmitter disconnected from the receiver for thirty (30) seconds to assure loss of lock. Three tests will be conducted with the noise reduced in 2dB, 4dB, & 6 dB steps below POF for each test. The signal will be reconnected to the DAR receiver, and acquisition time will be recorded for each noise level. Acquisition is audio with some impairments. The reproduced audio will be graded using the CCIR five-point impairment scale. This test series will be repeated with an analog interferer on the upper and lower first adjacent channels set for D/U ratios of +18 dB, +12 dB, +6 dB, and 0 dB. The undesired first adjacent channel will be modulated with processed audio. 	EO&C in lab	M	Acquisition time at each noise level and disconnect time.
	<u>2 Simulated acquisition with multipath and noise</u>	<ol style="list-style-type: none"> This test will be conducted four times, each with different multipath scenario. The multipath parameters will be those specified by the DAR channel characterization sub-group. Noise will be added until the signal fails. The DAR transmitter will be disconnected from the receiver to assure loss of lock for one second. The test will be repeated with the signal broken for 30 seconds. A different scenario will be selected. For each of the multipath scenarios, three tests will be conducted with the noise reduced to 2dB, 4dB, & 6 dB below POF for each test. The signal will be reconnected to the DAR receiver and acquisition time recorded for each of the test parameters in step #5. Acquisition is the reproduction of listenable music. The audio quality will be graded during the acquisition cycle. This test series will be repeated with an analog interferer on the upper and lower first adjacent channels set for D/U ratios of +18 dB, +12 dB, +6 dB, and 0 dB. The undesired first adjacent channel will be modulated with processed audio. 	EO&C in lab	M	Acquisition time at each noise level, MP scenario, and disconnect time.

REVISION #13		IBOC LABORATORY TEST GUIDELINES-FM BAND			October 8, 1998
Test Group	Test Number and Impairment	Test Description	Type of Evaluation	Sig. Level	Test Results & Data to be Recorded
K DAR quality	1. Audio test segments Quality Impairment	1. The nine quality segments selected by the DAR Subcommittee will be used for the quality tests. 2. Glockenspiel will be used for the impairment tests.	NA	NA	NA
	2 Quality transmission test	1. The quality test materials selected in test K-1 will be transmitted through each DAR system and recorded digitally. 2. Each recorded segment will then be sent to a subjective assessment laboratory.	Subjective EO&C in Lab	M	Assessed using the ITU-R continuous 5-grade impairment scale (See Appendix U of the DAR Subcommittee Laboratory Tests)

Quality Audio Test Segments Selected by the DAR Subcommittee		
Description	Duration	Source
Dire Straits cut	30s	Warner Bros. CD 7599-25264-2 (track 6)
Pearl Jam cut	30s	Sony/Epic CD ZK53136 (track 3) with processing ¹
Sounds of water	30s	Roland Dimensional Space Processor Demo. CD
Glockenspiel	16s	EBU SQAM CD (track 35/Index 1)
Bass Clarinet arpeggio	30s	EBU SQAM CD (track 17/Index 1) with processing ¹
Music and rain	11s	AT&T mix
Susan Vega with glass	11s	AA&T mix
Muted trumpet	9s	Original DAT recording, University of Miami
Harpsichord arpeggio	12s	EBU SQAM CD (track 40/Index 1)

¹Processing chain used: Aphex Compellor Model 300 (set for leveling only)
Dolby Spectral Processor Model 740
Aphex Dominator II Model 720

REVISION #13		IBOC LABORATORY TEST GUIDELINES - FM BAND			October 8, 1998		
Test Group	Test & Impairment	TEST PROCEDURE			Type of Evaluation	Desired Signal Level	Test Results Data to be Recorded
		Notes: 1. Performance tests will be conducted for each of the five FM stereo compatibility receivers, including signal/noise, stereo separation/signal level, and sensitivity to narrowband noise. Narrowband noise tests will measure D/U at a fixed receiver S/N (45 dB QPK) using a noise modulated laboratory signal generator deviated 5 kHz, starting at the channel center frequency and extending to 266 kHz above and below the channel center frequency, in 38 kHz increments. 2. Analog program channel compatibility receiver noise tests will use quasi-peak detection and a CCIR weighting filter. The received audio will be routed through a 15kHz low pass filter.					
L	<u>1 IBOC to host analog</u>	1. Five representative FM stereo receivers will be used for the compatibility tests. 2. The host FM transmitters will be set for a total of 75 kHz deviation with 1 kHz tone. The host analog transmitter will be modulated with pilot. 3. For each of the compatibility receivers the audio S/N will be measured with and without the digital IBOC signal. The host FM to digital power ratio used in the performance test will be used for the compatibility tests. If the proponent elects to use multiple analog to digital ratios for the compatibility tests, the performance tests will also be conducted at these ratios.			Objective	S	FM audio S/N with and without
DAR -> Analog							
(IBOC host analog) ->	<u>2 IBOC to host analog</u>	1. The same receivers used for test L.1 will be used for this test. 2. The desired audio signal will be moderately processed. 3. Stereo classical music, rock music, silence, and spoken voice will be used for the audio. 4. The host and reference FM channels will be set for a total 75 kHz deviation with 1 kHz tone. 5. For each analog receiver test, a digital audio recording will be made of the host IBOC analog audio signal with the digital signal turned on and off.			Subjective EO&C	S	Recordings for further subjective assessment or demonstrations
	<u>3 IBOC to host analog with multipath</u>	1. The same receivers used for test L-1 will be used for this test. 2. Classical music, rock music, silence, and spoken voice will be used for the audio with moderate audio processing. 3. The four multipath scenarios selected by the RF channel characterization sub-group of the DAR subcommittee will be used. 4. For each test receiver, an EO&C report will compare the IBOC analog signal quality and the analog reference signal.			EO&C in lab & subjective	M	Digital audio recordings for further subjective assessment
	<u>4 IBOC to subcarriers</u>	1. Using a wideband precision demodulator, the baseband noise floor (100 Hz to 300 kHz) will be plotted with pilot, subcarriers (3% RBDS, 8.5% 67 kHz FM analog, and 8.5% 92 kHz FM analog), digital signal and 1 kHz tone on the program channel. The noise will again be plotted with the 1 kHz program audio tone removed. 2. The 92 kHz analog subcarrier RMS S/N will be measured with and without the 1 kHz tone on the main program channel. The 92 kHz Dayton receiver used in the 1995 DAR tests will be used.			Objective	M	Plot baseband noise floor change with IBOC digital signal, program modulation Any noise change in 92 kHz subcarrier

REVISION #13		IBOC LABORATORY TEST GUIDELINES-FM BAND			October 8, 1998
Test Group	Test	TEST PROCEDURE Note:	Type of Evaluation	Desired Signal Level	Test Results & Data to be Recorded
M Analog -> DAR Analog to host IBOC	1 Host analog to IBOC digital with no other impairments	<ol style="list-style-type: none"> The analog signal will be heavily modulated with processed stereo rock music. The host FM signal will include subcarrier group A. The DAR signal will be modulated with the primary impairment audio test material. 			
	2 Host analog to IBOC digital with multipath	<ol style="list-style-type: none"> The host IBOC analog modulation will be set for 110% with heavy processing, and the lab staff will listen for digital impairments. If impairments are heard the analog modulation will be reduced until no impairments are heard. If impairments are not heard in step #1, the FM modulation will be increased until impairments are heard or 150 % modulation is reached. The test results will be recorded on digital audio tape (DAT). 	EO&C in lab	M	Modulation percentage verses impairments
		<ol style="list-style-type: none"> The four multipath scenarios will be used for this test The analog modulation will be set for 110%. If impairments are heard the analog modulation will be reduced until no impairments are heard. The test results will be recorded on digital audio tape (DAT). 	EO&C in lab	M	Modulation percentage verses impairments

Appendix B. Recommended Lab Test Outline – AM-band

REVISION #2 October 8, 1998		IBOC LABORATORY TEST GUIDELINES-AM BAND			
Test Group	Test & Impairment	TEST PROCEDURE Note: The audio impairment test material will be used for the TOA test (see test K).	Type of Evaluation	Signal Level	Test Results Data to be Recorded
A Calibration	1 Power (each test day or as needed)	1. IBOC analog and digital power will be read separately. 2. The digital average and peak power will be measured for each system at least once.	Objective	NA	Power level
	2 Spectrum (each test day or as needed)	1. A spectrum analyzer plot of the system RF spectrum will be taken for each test. 2. The spectrum analyzer will be set up in accordance with FCC 73.44.	Objective	M	Laboratory log
	3 TOA (daily or as needed)	Gaussian noise will be added to the signal in 0.25 dB steps until TOA occurs (See test B). Test C-4, weak signal test, will also be conducted.	EO&C and Objective	M	TOA level
	4 Audio recording (as needed)	An audio recording will be made of all of the proponent audio channels (analog and digital).	EO&C	M & W	Digital audio recording for the test record
	5 Proof IBOC (weekly)	During the analog compatibility tests, a proof of performance test will be conducted weekly on the analog portion of the proponent IBOC systems. A high quality demodulator will be used for this test.	Objective	Varying	Record of frequency response, separation, and distortion for the test record
	6 Reference analog TX total proof	If a reference transmitter is used, a proof of performance test will be conducted on this transmitter, with and without subcarriers, prior to the compatibility tests. Both subcarrier groups will be calibrated.	Objective	NA	Test records
	7 Monitor calibration (weekly or as needed)	The analog modulation monitors will be calibrated monthly.	Objective	NA	Calibration results recorded in laboratory test record
	8 Test bed calibration (monthly)	All of the critical components in the test bed, transmission path simulators, attenuators, combiners, filters, generators, and measuring instruments, will be calibrated on a monthly schedule.	Objective	NA	Calibration record in test record

REVISION #2 October 8, 1998		IBOC LABORATORY TEST GUIDELINES-AM BAND			
Test Group	Test & Impairment	TEST PROCEDURE	Type of Evaluation	Signal Level dBm	Test Results Data to be Recorded
		Note: 1. Glockenspiel will be used for the digital audio impairment tests. 2. The detailed procedure for noise measurements will be supplied. See Appendix S of the Digital Audio Radio Laboratory Tests Report, August 11, 1995. 3. Clipped pink noise will be used for the host analog signal.			
B Impairment tests for characterization of DAR signal failure	1 Noise	1. Gaussian noise will be increased to TOA & POF (0.25 dB steps) and the levels logged. 2. From the TOA the noise will be increased in 0.5 dB steps until the noise is 0.5 dB beyond POF. For each 0.5 dB step a digitally recording will be made for expert subjective assessment.	EO&C	M	Noise level at TOA & POF

REVISION #2 October 8, 1998		IBOC LABORATORY TEST GUIDELINES-AM BAND			
	Test & Impairment	TEST PROCEDURE Notes:	Type of Evaluation	Signal Level	Test Results Data to be Recorded
C DAR with special impairment	1 Impulse noise	4. A generator capable of generating 100 nanosecond wide pulses with a rise and decay time of 3 to 4 nanoseconds will be used for the test. Pulse rates between 100 Hz to 1000 Hz will be used. All systems will be tested with a 120 Hz signal. 5. The pulse generator output will be mixed with the DAR signal. 6. The amplitude of the pulses will be increased until the laboratory specialist hears the TOA.	EO&C	M	Pulse amplitude in Volts P-P at TOA
	2 Weak signal	4. Starting with a medium signal level, the signal will be reduced to TOA & POF (0.25 dB steps). 5. A single audio impairment recording will be used for this test. 6. Characterize failure between TOA and POF in 0.5 dB steps. Note- weak signal test should be used to monitor the performance of the receiver hardware but should not be used to evaluate the proposed system.	EO&C	Varying	Signal level at TOA & POF

REVISION #2 October 8, 1998		IBOC LABORATORY TEST GUIDELINES-AM BAND			
Test Group	Test Number and Impairment	TEST PROCEDURE Note:	Type of Evaluation	Sig. Level	Test Results & Data to be Recorded
D DAR -> DAR	1 Co-channel	<ol style="list-style-type: none"> Two additional IBOC transmitters supplied by each proponent will generate the undesired DAR signals. The desired host analog signal will be modulated with clipped pink noise. Glockenspiel will be used for the digital audio impairment tests. 	EO&C in Lab	M	D/U & levels at TOA & POF Co-channel failure characteristics
	2 First adjacent	<ol style="list-style-type: none"> The undesired lower first adjacent composite IBOC signal will be increased in 0.5 dB steps until the TOE and POF are found. The test will be repeated with an upper first adjacent undesired signal. The test will be repeated with simultaneous upper and lower first adjacent undesired signals. 	EO&C in Lab	M	D/U & levels at TOA & POF
	3. Second adjacent	<ol style="list-style-type: none"> The undesired lower second adjacent composite IBOC signal will be increased in 0.5 dB steps until the TOE and POF are found. The test will be repeated with an upper second adjacent undesired signal. The test will be repeated with simultaneous upper and lower second adjacent undesired signals. 	EO&C in Lab	M	D/U & levels at TOA & POF
	4 Third adjacent	<ol style="list-style-type: none"> The first part of this test will be conducted with a minimum out-of-channel power. The undesired lower second adjacent DAR signal will be increased in 0.5 dB steps until the TOA and POF are observed. The test will be repeated with an upper third adjacent undesired signal. Simultaneous upper and lower second adjacent tests will be conducted. The tests will be repeated with the undesired signal's out-of-channel power increased in 5 dB steps until TOA and POF are detected in the desired IBOC audio. 	EO&C in Lab	M	D/U & levels at TOA & POF Third adjacent D/U with and without out-of-band components

REVISION #2 October 8, 1998		IBOC LABORATORY TEST GUIDELINES - AM BAND			
Test Group	Test & Impairment	TEST PROCEDURE	Type of Evaluation	Desired Signal Level	Test Results Data to be Recorded
		Notes: 1. These tests will compare the IBOC to analog with the analog to analog interference			
F DAR -> Analog (interference to an analog receiver with no other impairments)	<u>1 Co-channel objective</u>	1. The three AM receivers characterized in test L will be used for the AM band tests. 2. The desired AM transmitters will be set for 100% modulation. The desired transmitter will not be modulated. 3. The CCIR recommendation 412-4 weighting filter will be used for the program channel S/N measurements. 4. Increasing the undesired signal until the resulting audio signal/noise ratios are 25 and 40 dB (QPK), the D/U will be measured for the interference combinations: analog -> analog, and the DAR -> analog.	Objective	M	D/U at specified S/N for A -> A and D -> A
	<u>2 1st & 2nd adjacent</u>	1. The first and second adjacent channel procedures are the same as the co-channel procedures in F.1.1. The first and second adjacent channel measurement will be made with a single undesired signal operating above and below the desired signal frequency.	Objective	M	D/U at specified S/N for A -> A and D -> A
	<u>3 Co-channel</u>	1. The receivers used in step F.1.1 will be used for the subjective tests. 2. Classical music, rock music, and silence will be used for the desired channel analog audio. 3. The test will be conducted using the D/U that produced 25 dB and 40 dB audio S/N in test F-1. 4. The A to A reference and the test will be recorded on digital tape for demonstration or evaluation.	Subjective EO&C	M	Recordings for industry evaluation
	<u>5 1st & 2nd adjacent</u>	1. The subjective adjacent channel tests will use the procedures outlined in F.1, F.2, and F.3.	Subjective EO&C	M	Recordings for industry evaluation

REVISION #2 October 8, 1998		IBOC LABORATORY TESTS GUIDELINES - AM BAND			
Test Group	Test & Impairment	TEST PROCEDURE	Type of Evaluation	Desired Signal Level	Test Results Data to be Recorded
		Note: 1. The undesired analog signal will be modulated with processed rock stereo. 2. The host analog will be modulated with clipped pink noise. 3. Glockenspiel will be used for the digital audio impairment test.			
H Analog -> DAR (no other impairments)	<u>1 Co-channel</u>	1. The undesired co-channel analog standard AM signal will be increased in 0.5 dB steps until the TOA and POF are found.	EO&C in lab	M	D/U at TOA & POF
	<u>2 1st adjacent</u>	1. The undesired lower 1st adjacent analog standard AM signal will be increased in 0.5 dB steps until the TOA and POF are found. 2. This test will be repeated with an upper 1st adjacent undesired signal.	EO&C in lab	M	D/U at TOA & POF.
	<u>3 Simultaneous upper and lower 1st adjacent</u>	1 Simultaneous upper and lower 1st adjacent analog signals will be increased until the TOA and POF are heard (0.5 dB steps).	EO&C in lab	M	D/U at TOA & POF.
	<u>4 2nd adjacent</u>	Note - this test will be conducted on both upper and lower 2nd adjacent channels. 1. The undesired analog signal will be increased until the TOA and POF are observed (1.0 dB steps). 2. Simultaneous upper and lower second adjacent tests will be conducted.	EO&C in lab	M	D/U at TOA & POF

REVISION #2 October 8, 1998		IBOC LABORATORY TEST GUIDELINES – AM BAND			
Test Group	Test & Impairment	TEST PROCEDURE	Type of Evaluation	Desired Signal Level	Test Results Data to be Recorded
		Note: 1. The impairment audio will be Mozart track 67 on the SQAM disk. 2. The host analog channel will be modulated with clipped pink noise. 3. If clipped pink noise is heard during the test, the test will be repeated with the impairment audio simultaneously transmitted on the digital and host analog channels. 4. Each test will be repeated at least five times and the results averaged.			
J	<u>1 Simulated</u> DAR acquisition and reacquisition tests <u>weak signal failure and acquisition</u>	1. Noise will be added to the signal in 0.25 dB steps until POF is found. The POF level will be recorded. 2. The DAR transmitter will be disconnected from the receiver for one (1) second to assure loss of lock. 3. The test will be repeated with the transmitter disconnected from the receiver for thirty (30) seconds to assure loss of lock. 4. Three tests will be conducted with the noise reduced in 2dB, 4dB, & 6 dB steps below POF for each test. 5. The signal will be reconnected to the DAR receiver, and acquisition time will be recorded for each noise level. Acquisition is audio with some impairments. The reproduced audio will be graded using the CCIR five-point impairment scale.	EO&C in lab	M	Acquisition time at each noise level and disconnect time.

REVISION #2 October 8, 1998		IBOC LABORATORY TEST GUIDELINES-AM BAND			
Test Group	Test Number and Impairment	Test Description	Type of Evaluation	Sig. Level	Test Results & Data to be Recorded
K DAR quality	1. Audio test segments Quality Impairment	1. The nine quality segments selected by the DAR Subcommittee will be used for the quality tests. 2. Glockenspiel will be used for the impairment tests.	NA	NA	NA
	2 Quality transmission test	1. The quality test materials selected in test K-1 will be transmitted through each DAR system and recorded digitally. 2. Each recorded segment will then be sent to a subjective assessment laboratory.	Subjective EO&C in Lab	M	Assessed using the ITU-R continuous 5-grade impairment scale (See Appendix U of the DAR Subcommittee Laboratory Tests Report)

Quality Audio Test Segments Selected by the DAR Subcommittee		
Description	Duration	Source
Dire Straits cut	30s	Warner Bros. CD 7599-25264-2 (track 6)
Pearl Jam cut	30s	Sony/Epic CD ZK53136 (track 3) with processing ¹
Sounds of water	30s	Roland Dimensional Space Processor Demo. CD
Glockenspiel	16s	EBU SQAM CD (track 35/Index 1)
Bass Clarinet arpeggio	30s	EBU SQAM CD (track 17/Index 1) with processing ¹
Music and rain	11s	AT&T mix
Susan Vega with glass	11s	AA&T mix
Muted trumpet	9s	Original DAT recording, University of Miami
Harpsichord arpeggio	12s	EBU SQAM CD (track 40/Index 1)

¹Processing chain used: Aphex Compellor Model 300 (set for leveling only)
Dolby Spectral Processor Model 740
Aphex Dominator II Model 720

REVISION #2		IBOC LABORATORY TEST GUIDELINES - AM BAND			October 8, 1998		
Test Group	Test & Impairment	TEST PROCEDURE			Type of Evaluation	Desired Signal Level	Test Results Data to be Recorded
		Notes: 1. The AM receiver compatibility performance tests are those outlined in the August 11, 1995 EIA DAR laboratory test report. 2. Analog program channel compatibility receiver noise tests will use quasi-peak detection and a CCIR weighting filter.					
L DAR -> Analog (IBOC -> host analog)	<u>1 IBOC to host analog</u>	1. Three representative AM receivers will be used for the compatibility tests. 2. The host AM transmitters will be set for 100% modulation with 1 kHz tone. The host analog transmitter will not be modulated. 3. For each of the compatibility receivers the audio S/N will be measured with and without the digital IBOC signal. The host AM to digital power ratio used in the performance test will be used for the compatibility tests. If the proponent elects to use multiple analog to digital ratios for the compatibility tests, the performance tests will also be conducted at these ratios.			Objective	S	AM audio S/N with and without
	<u>2 IBOC to host analog</u>	1. The same receivers used for test L.1 will be used for this test. 2. The desired audio signal will be moderately processed. 3. Classical music, rock music, silence, and spoken voice will be used for the audio. 4. The host and reference AM transmitters will be set for a 100% modulation with a 1 kHz tone. 5. For each analog receiver test, a digital audio recording will be made of the host IBOC analog audio signal with the digital signal turned on and off.			Subjective EO&C	S	Recordings for further subjective assessment or demonstration

REVISION #2		IBOC LABORATORY TEST GUIDELINES-AM BAND			October 8, 1998
Test Group	Test	TEST PROCEDURE Note:	Type of Evaluation	Desired Signal Level	Test Results & Data to be Recorded
M Analog -> DAR Analog to host IBOC	1 Host analog to IBOC digital with no other impairments	<ol style="list-style-type: none"> 1. The analog signal will be heavily modulated with processed rock music. 2. The DAR signal will be modulated with the primary impairment audio test material. 			
		<ol style="list-style-type: none"> 1. The host IBOC analog modulation will be set for 100% with heavy processing, and the lab staff will listen for digital impairments. 2. If impairments are heard the analog modulation will be reduced until no impairments are heard. 3. If impairments are not heard in step #1, the AM modulation will be increased until impairments are heard or 150 % modulation is reached. 4. The test results will be recorded on digital audio tape (DAT). 	EO&C in lab	M	Modulation percentage verses impairments

Appendix C. Analog Receiver Selection (Compatibility Testing)

The suggested test procedures described in Appendices A (FM) and B (AM) include compatibility tests designed to determine the effect that IBOC DAB has on existing analog main channel audio signals. The NRSC recommends that these tests be done using commercially-available analog receivers representative of a cross-section of receivers in use by consumers since, during the initial and transitional phases of IBOC DAB service introduction, these are the receivers which will primarily be in use, and therefore of primary interest with respect to analog compatibility.

In previous NRSC IBOC DAB tests, five FM and three AM radios were selected for use in compatibility testing, listed in Table C-1.² For FM, radios were selected from four categories: auto, portable, home Hi-Fi (high end), and home Hi-Fi (competitive). Two automobile radios were selected because of their large consumer populations and because of their dramatically different stereo-to-mono "blend" implementations. These auto radios also showed high adjacent channel rejection. The portable and personal portable use similar circuitry and have less adjacent channel rejection. The high end home Hi-Fi radios had good 2nd adjacent channel rejection, but exhibited first adjacent channel rejection characteristics similar to that found in the portable and home radios.

Table C-1. Analog Receivers Used in NRSC IBOC DAB Tests (1995)

CATEGORY	MAKE & MODEL	FM	AM
Auto	Delco model # 16192463	✓	✓
Auto	Ford model #F4XF-19B132-CB	✓	
Portable	Panasonic RX-FS430	✓	✓
Home Hi-Fi (high end)	Denon TU-380RD	✓	✓
Home Hi-Fi (competitive)	Pioneer SX-201	✓	

Table C-2 shows the result of the FM -> FM D/U tests that were conducted using the five radios. For the D/U measurements, the undesired signal RF level was adjusted for a 45 dB signal-to-noise ratio in the main channel audio of the desired signal. The audio noise measurements were made using quasi-peak detection, a 15 kHz low pass filter, and the CCIR filter. The desired signal level was -62 dBm. Antenna matching networks were used when needed. The portable and home receivers were tested in a shielded box that eliminated interference from other electronic devices in the laboratory. The two auto radios did not need additional shielding.

² See "Consumer Electronics Group, Electronic Industries Association, Digital Audio Radio Laboratory Tests - Transmission Quality Failure Characterization and Analog Compatibility, August 11, 1995" for additional information. Appendix H contains characterization data on the receivers in Table C-1.

Table C-2. FM Analog-to-analog D/U test results

- D/U values at which main channel audio signal achieves a 45 dB S/N ratio
- Test data from 1995 IBOC DAB laboratory tests (see footnote 2)

RECEIVER	CO-CHANNEL (D/U, dB)	1ST ADJ. CHANNEL (D/U, dB)	2ND ADJ. CHANNEL (D/U, dB)	113 kHz TEST (S/N, dB)
Delco	36.2	4.7	-45	No change
Ford	35.2	-6.1	-45.3	No change
Panasonic	40.9	27.3	-10.1	33.6
Denon	43.4	18.0	-28.9	34.0
Pioneer	44.2	26.6	-15.0	33.1

Additional information regarding receivers is included in Table C-3 and Figure C-1 which present information about radio listening by location (source: RADAR ® 56, Fall 1997, © Copyright Statistical Research, Inc.).

Table C-3. Radio Listening by Location

Weekdays (Monday-Friday, 24 hours)

Source: RADAR ® 56, Fall, 1997 (C) Copyright Statistical Research, Inc.

	PERCENT OF LISTENERS IN...		
	HOME	CAR	WORK OR OTHER
Persons 12+	37.1	42.3	20.6
Teens 12-17	43.3	36.5	20.2
Adults 18+	36.2	43.2	20.6
Men 18+	33.5	44	22.6
Women 18+	38.9	42.3	18.8

Figure C-1. Radio Listening by Location

Weekdays (Monday-Friday, 24 hours)

Source: RADAR © 56, Fall, 1997 (C) Copyright Statistical Research, Inc.

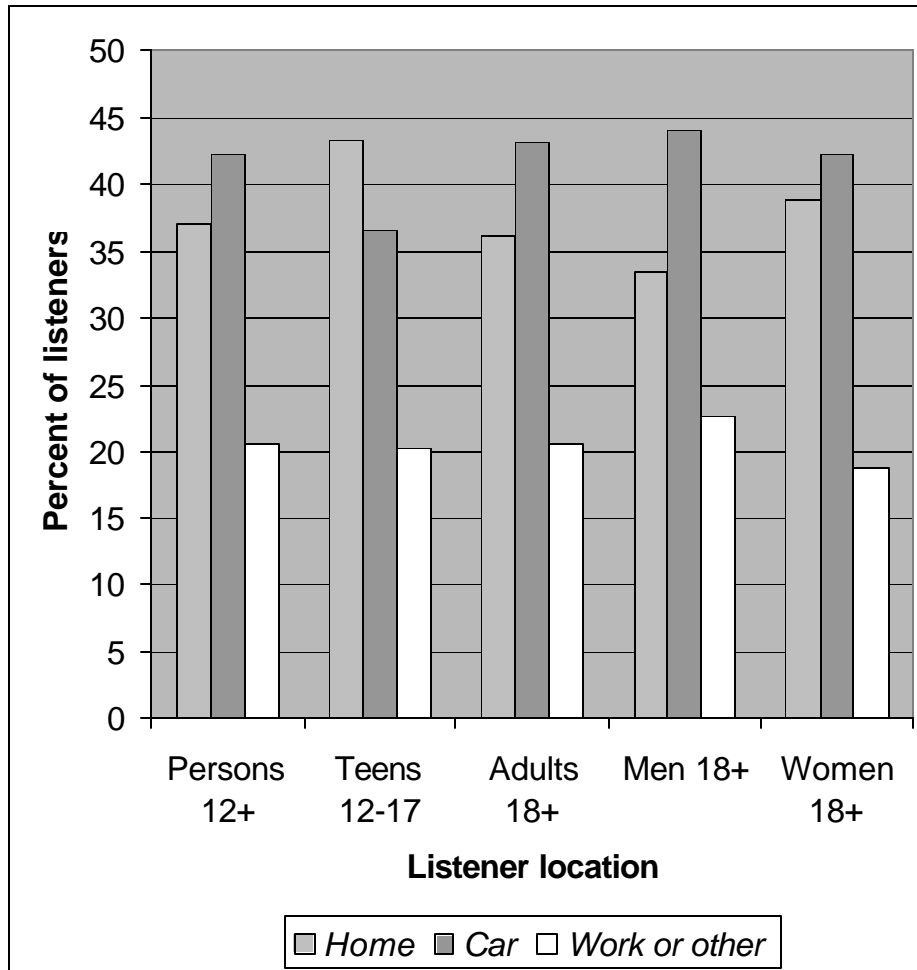

Appendix D. Test Matrix – Lab Test Guidelines, FM-band Portion

LAB TESTS, FM-BAND PORTION						INTERFERERS			COMMENTS
TEST	DESCRIPTION	AWGN	LINEAR	NON-LINEAR	FADING	Co-CHAN	1ST-ADJ	2ND-ADJ	
A	System calibration								
1)	Average and peak RF power measurements		✓						
2)	RF spectrum plot		✓						
3)	Digital audio subjective performance baseline	✓	✓						
4)	Baseline characterization of system digital performance	✓	✓						
5)	Analog proof-of-performance test results								
6)	Calibration record of equipment								
B	IBOC system performance with AWGN								
1)	Linear channel, no interferers	✓	✓						<ul style="list-style-type: none"> • Digital audio performance • Data transmission performance
2)	Linear channel, 1st-adjacent channel interference	✓	✓				✓		
3)	Multipath fading channel, no interferers	✓			✓				
4)	Multipath fading channel, 1st-adjacent channel interference	✓			✓		✓		
C	IBOC system performance with special impairments								
1)	Impulse noise		✓						<ul style="list-style-type: none"> • Digital audio performance • Data transmission performance
2)	Impulse noise, 1st-adjacent channel interference		✓				✓		
3)	Narrowband noise		✓						
4)	Narrowband noise, 1st-adjacent channel interference		✓				✓		
5)	Airplane flutter		✓						
6)	Airplane flutter, 1st-adjacent channel interference		✓				✓		
7)	Weak signal		✓						
8)	Weak signal, 1st-adjacent channel interference		✓				✓		
9)	Delay spread/doppler		✓						
10)	Delay spread/doppler, 1st-adjacent channel interference		✓				✓		
D	IBOC “digital-to-digital” compatibility performance								
1)	Co-channel interference		✓			✓			<ul style="list-style-type: none"> • Digital audio performance • Data transmission performance
2)	Single 1st-adjacent channel interference		✓				✓		
3)	Simultaneous upper and lower 1st-adjacent channel interference		✓				✓		
4)	Single 2nd-adjacent channel interference		✓					✓	
5)	Single 2nd-adjacent channel interference w/1st adj. channel interference		✓				✓	✓	

LAB TESTS, FM-BAND PORTION						INTERFERERS			COMMENTS
TEST	DESCRIPTION	AWGN	LINEAR	NON-LINEAR	FADING	Co-CHAN	1ST-ADJ	2ND-ADJ	
6)	Simultaneous upper and lower 2nd-adjacent channel interference		✓					✓	
7)	Simultaneous upper and lower 2nd-adjacent channel interference with non-linearity			✓				✓	
E	IBOC “digital-to-digital” compatibility performance in a multipath fading channel								
1)	Co-channel interference				✓	✓			<ul style="list-style-type: none"> Digital audio performance Data transmission performance
2)	Single 1st-adjacent channel interference				✓		✓		
3)	Simultaneous upper and lower 1st-adjacent channel interference				✓		✓		
4)	Single 2nd-adjacent channel interference				✓			✓	
5)	Single 2nd-adjacent channel interference w/1st adj. channel interference				✓		✓	✓	
6)	Simultaneous upper and lower 2nd-adjacent channel interference				✓			✓	
7)	Simultaneous upper and lower 2nd-adjacent channel interference with non-linearity			✓	✓			✓	
F	IBOC “digital-to-analog” compatibility performance								
1)	Co-channel interference		✓			✓			<ul style="list-style-type: none"> Analog main channel audio performance
2)	Single 1st-adjacent channel interference		✓				✓		
3)	Simultaneous upper and lower 1st-adjacent channel interference		✓				✓		
4)	Single 2nd-adjacent channel interference		✓					✓	
5)	Single 2nd-adjacent channel interference w/1st adj. channel interference		✓				✓	✓	
6)	Simultaneous upper and lower 2nd-adjacent channel interference		✓					✓	
G	IBOC “digital-to-analog” compatibility performance in a multipath fading channel								
1)	Co-channel interference				✓	✓			<ul style="list-style-type: none"> Analog main channel audio performance
2)	Single 1st-adjacent channel interference				✓		✓		
3)	Simultaneous upper and lower 1st-adjacent channel interference				✓		✓		
4)	Single 2nd-adjacent channel interference				✓			✓	
5)	Single 2nd-adjacent channel interference w/1st adj. channel interference				✓		✓	✓	

LAB TESTS, FM-BAND PORTION						INTERFERERS			COMMENTS
TEST	DESCRIPTION	AWGN	LINEAR	NON-LINEAR	FADING	Co-CHAN	1ST-ADJ	2ND-ADJ	
6)	Simultaneous upper and lower 2nd-adjacent channel interference				✓			✓	
H	IBOC “analog-to-digital” compatibility performance								
1)	Single 1st-adjacent channel interference		✓				✓		<ul style="list-style-type: none"> Digital audio performance Data transmission performance
2)	Simultaneous upper and lower 1st-adjacent channel interference		✓				✓		
3)	Single 2nd-adjacent channel interference		✓					✓	
I	IBOC “analog-to-digital” compatibility performance in a multipath fading channel								
1)	Single 1st-adjacent channel interference				✓		✓		<ul style="list-style-type: none"> Digital audio performance Data transmission performance
2)	Simultaneous upper and lower 1st-adjacent channel interference				✓		✓		
3)	Single 2nd-adjacent channel interference				✓			✓	
4)	Simultaneous upper and lower 2nd-adjacent channel interference				✓			✓	
J	IBOC acquisition/re-acquisition performance								
1)	Short interruption, linear channel		✓						<ul style="list-style-type: none"> Acquisition / re-acquisition performance
2)	Long interruption, linear channel		✓						
3)	Short interruption, linear channel, AWGN	✓	✓						
4)	Long interruption, linear channel, AWGN	✓	✓						
5)	Short interruption, linear channel, 1st-adj. channel interference		✓				✓		
6)	Long interruption, linear channel, 1st-adj. channel interference		✓				✓		
7)	Short interruption, fading channel				✓				
8)	Long interruption, fading channel				✓				
9)	Short interruption, AWGN, fading channel	✓			✓				
10)	Long interruption, AWGN, fading channel	✓			✓				
11)	Short interruption, fading channel, 1st-adj. channel interference				✓		✓		
12)	Long interruption, fading channel, 1st-adj. channel interference				✓		✓		
K	DAB quality								
1)	Subjective assessment report of unimpaired IBOC audio quality (linear channel) versus analog FM		✓						<ul style="list-style-type: none"> Suggested source and reference audio available from NRSC See Sect. 4.2
2)	“Long-form” DAT through IBOC system		✓						

LAB TESTS, FM-BAND PORTION						INTERFERERS			COMMENTS
TEST	DESCRIPTION	AWGN	LINEAR	NON-LINEAR	FADING	Co-CHAN	1ST-ADJ	2ND-ADJ	
L	IBOC “digital-to-host analog” compatibility performance								
1)	Host analog main channel audio performance versus presence or absence of IBOC digital signal energy		✓						<ul style="list-style-type: none"> • Host analog main channel audio performance • Host subcarrier performance
2)	Host analog main channel audio performance versus presence or absence of IBOC digital signal energy				✓				
3)	Host subcarrier audio and/or data performance versus presence or absence of IBOC digital signal energy		✓						
4)	Host subcarrier audio and/or data performance versus presence or absence of IBOC digital signal energy				✓				
M	IBOC “host analog-to-digital” compatibility performance								
1)	Digital audio, data transmission performance versus percent modulation of analog host signal		✓						<ul style="list-style-type: none"> • Digital audio performance • Data transmission performance
2)	Digital audio, data transmission performance versus percent modulation of analog host signal				✓				

Appendix E. Test Matrix – Lab Test Guidelines, AM-band Portion

LAB TESTS, AM-BAND PORTION						INTERFERERS				COMMENTS
TEST	DESCRIPTION	AWGN	LINEAR			Co-CHAN	1ST-ADJ	2ND-ADJ	3RD-ADJ	
A	System calibration									
1)	Average and peak RF power measurements		✓							
2)	RF spectrum plot		✓							
3)	Digital audio subjective performance baseline	✓	✓							
4)	Baseline characterization of system digital performance	✓	✓							
5)	Analog proof-of-performance test results									
6)	Calibration record of equipment									
B	IBOC system performance with AWGN									
1)	Linear channel, no interferers	✓	✓							<ul style="list-style-type: none"> Digital audio performance Data transmission performance
C	IBOC system performance with special impairments									
1)	Impulse noise		✓							<ul style="list-style-type: none"> Digital audio performance Data transmission performance
2)	Weak signal		✓							
D	IBOC “digital-to-digital” compatibility performance									
1)	Co-channel interference		✓			✓				<ul style="list-style-type: none"> Digital audio performance Data transmission performance
2)	Single 1st-adjacent channel interference		✓				✓			
3)	Simultaneous upper and lower 1st-adjacent channel interference		✓				✓			
4)	Single 2nd-adjacent channel interference		✓					✓		
5)	Simultaneous upper and lower 2nd-adjacent channel interference		✓					✓		
6)	Single 3rd-adjacent channel interference								✓	
F	IBOC “digital-to-analog” compatibility performance									
1)	Co-channel interference		✓			✓				<ul style="list-style-type: none"> Analog main channel audio performance
2)	Single 1st-adjacent channel interference		✓				✓			
3)	Single 2nd-adjacent channel interference		✓					✓		

LAB TESTS, AM-BAND PORTION						INTERFERERS				COMMENTS
TEST	DESCRIPTION	AWGN	LINEAR			Co-CHAN	1ST-ADJ	2ND-ADJ	3RD-ADJ	
H	IBOC “analog-to-digital” compatibility performance									
1)	Co-channel interference					✓				<ul style="list-style-type: none"> Digital audio performance Data transmission performance
2)	Single 1st-adjacent channel interference		✓				✓			
3)	Simultaneous upper and lower 1st-adjacent channel interference		✓				✓			
4)	Single 2nd-adjacent channel interference									
3)	Simultaneous upper and lower 2nd-adjacent channel interference		✓					✓		
J	IBOC acquisition/re-acquisition performance									
1)	Short interruption, linear channel		✓							<ul style="list-style-type: none"> Acquisition / re-acquisition performance
2)	Long interruption, linear channel		✓							
3)	Short interruption, linear channel, AWGN	✓	✓							
4)	Long interruption, linear channel, AWGN	✓	✓							
K	DAB quality									
1)	Subjective assessment report of unimpaired IBOC audio quality (linear channel) versus analog AM (and optionally, analog FM)		✓							<ul style="list-style-type: none"> Suggested source and reference audio available from NRSC See Sect. 4.2
2)	“Long form” DAT through IBOC system		✓							
L	IBOC “digital-to-host analog” compatibility performance									
1)	Host analog main channel audio performance versus presence or absence of IBOC digital signal energy		✓							<ul style="list-style-type: none"> Host analog main channel audio performance
M	IBOC “host analog-to-digital” compatibility performance									
1)	Digital audio, data transmission performance versus percent modulation of analog host signal		✓							<ul style="list-style-type: none"> Digital audio performance Data transmission performance

Appendix F. DAB Subcommittee Goals & Objectives



2500 Wilson Boulevard
Arlington, VA 22201-3834
(703) 907-7500
FAX (703) 907-7501

NATIONAL RADIO SYSTEMS COMMITTEE



1771 N Street, NW
Washington, DC 20036-2891
(202) 429-5339
FAX (202) 775-4981

5/14/98

DAB Subcommittee

Goals & Objectives

(as adopted by the Subcommittee on May 14, 1998)

Objectives

- (a) To study IBOC DAB systems and determine if they provide broadcasters and users with:
- A digital signal with significantly greater quality and durability than available from the AM and FM analog systems that presently exist in the United States;
 - A digital service area that is at least equivalent to the host station's analog service area while simultaneously providing suitable protection in co-channel and adjacent channel situations;
 - A smooth transition from analog to digital services.
- (b) To provide broadcasters and receiver manufacturers with the information they need to make an informed decision on the future of digital audio broadcasting in the United States, and if appropriate to foster its implementation.

Goals

To meet its objectives, the Subcommittee will work towards achieving the following goals:

- (a) To develop a technical record and, where applicable, draw conclusions that will be useful to the NRSC in the evaluation of IBOC systems;
- (b) To provide a direct comparison between IBOC DAB and existing analog broadcasting systems, and between an IBOC signal and its host analog signal, over a wide variation of terrain and under adverse propagation conditions that could be expected to be found throughout the United States;
- (c) To fully assess the impact of the IBOC DAB signal upon the existing analog broadcast signals with which they must co-exist;
- (d) To develop a testing process and measurement criteria that will produce conclusive, believable and acceptable results, and be of a streamlined nature so as not to impede rapid development of this new technology;
- (e) To work closely with IBOC system proponents in the development of their laboratory and field test plans, which will be used to provide the basis for the comparisons mentioned in Goals (a) and (b);
- (f) To indirectly participate in the test process, by assisting in selection of (one or more) independent testing agencies, or by closely observing proponent-conducted tests, to insure that the testing as defined under Goal (e) is executed in a thorough, fair and impartial manner.

Appendix G. IBOC Status Report (6/98)

"In-band/on-channel (IBOC) DAB – a Status Report," published in the proceedings of the 1998 Radio Montreux Conference.