



## **Appendix E**

---

### **FM Field Test Procedures & Notes**

---

**July 7, 2001**

#### **iBiquity Digital Corporation**

**8865 Stanford Boulevard, Suite 202  
Columbia, Maryland 21045  
(410) 872-1530**

**20 Independence Boulevard  
Warren, New Jersey 07059  
(908) 580-7000**

## TABLE OF CONTENTS

1.	Introduction	1
2.	Scope & Use	1
3.	Related Documents	1
4.	Summary Field Test Procedure	2
4.1	Objectives & Methods	2
4.1.1	The Auditor	2
4.1.1.1	Other Observers	3
4.2	Preparation	3
4.3	Execution	3
4.4	Data Recording & Handling	4
4.4.1	Automatically Recorded Data	4
4.4.2	Manually Recorded Data	4
4.4.2.1	Test Segment Notebook	5
4.4.2.2	Test Platform Notebook	5
4.4.3	Data Identification	5
5.	Field Test Preparation	5
5.1	Transmission Site	5
5.1.1	Preparation & Configuration	5
5.1.1.1	Studio Transmission Link (STL)	5
5.1.1.2	RF Monitoring Points	6
5.2	Drive Test Platform	6
5.2.1	Description	6
5.2.1.1	Hardware	6
5.2.1.2	Test Automation Software	12
5.2.2	Preparation	12
5.2.2.1	Test Receivers	12
5.2.2.2	Test Van Subsystem Characterization & Proofs	13
5.2.2.3	Mobile Test Platform System Certification	17
5.3	Calibration of Test Equipment	19
6.	Field Test Execution	19
6.1	Station Characterization	19
	Table 1: Transmission Site Measurements	21
6.1.1	Off-air Station Characterization	21
6.2	Performance Tests	23
	Test Sequence Number	24
6.2.1	Performance Test Receivers	24

6.3	Compatibility Tests	25
6.3.1	FM Host and 1 <sup>st</sup> Adjacent Compatibility Tests	25
6.3.1.1	Host Compatibility and 1 <sup>st</sup> Adjacent Compatibility Test Receivers	26
6.3.1.2	Compatibility Testing of Receivers with Integral Antennas (Sony CFD-S32 or equivalent)	26
6.3.2	SCA Compatibility Tests	28
6.3.2.1	SCA Compatibility Test Receivers	28
7.	Data Handling	29
7.1	File naming conventions	29
7.1.1	Data Files	29
7.1.2	PC File Storage – Disks, Tapes and Cartridges	29
7.1.2.1	File Storage Disks	29
7.1.3	MDM Multi-track Tapes	30
7.1.4	Hardcopy	30
7.1.5	Miscellaneous	31
7.2	Data Delivery, Archival and Reporting	31
7.2.1	Data Backup Requirements	31
7.2.1.1	Daily	31
7.2.1.2	End of Test Segment	32
7.2.2	Data Distribution and Delivery	32
8.	Field Test Personnel	32
8.1	Engineering Manager	32
8.2	Program Manager	32
8.3	Auditing Engineers (Auditors)	32
8.4	Supervising Engineers	33
8.5	Test Engineers	33
9.	Procedural Deviations	33
10.	Attachments	I

## Introduction

On 14 December 2000, the National Radio Systems Committee Digital Audio Broadcasting Subcommittee approved the Test Procedures Working Group's FM Field Test Procedures for the testing of iBiquity's FM IBOC system. This document and its attachments provide additional details necessary for complete and proper execution of the FM field test program.

## Scope & Use

This document is a companion to the NRSC's FM Field Test Procedures. It contains procedural details and notes not provided within the NRSC document. The areas addressed are:

- Configuration and proofing of transmission equipment
- Drive test platform hardware and software configurations
- Drive test platform proof and operation
- Performance test procedures
- Compatibility test procedures
- Auditing requirements and procedures
- Data handling
- Reporting and oversight requirements
- Procedural exception handling

This document is intended to guide the testing team through the critical elements of the NRSC's FM Field Testing Program, providing structure and removing ambiguity in the execution of the constituent testing processes. This document is intended for the use of those skilled in the art and engineering of RF field and laboratory testing. Thus, some procedurals are not described in full detail, but are left to the expertise of the engineering test team. The test team is expected to follow *accepted engineering practices*, the cornerstone of which is detailed documentation of any and all procedures used in test execution.

## Related Documents

Document	Author/Organization	Notes
<i>IBOC Field Test Procedures – FM Band</i>	NRSC DAB Subcommittee	This is the overall guiding test procedure.
<i>Tascam DA-98 User Manual</i>	Tascam/Teac Corporation	Describes operation of the test platform digital audio recorder.

## Summary Field Test Procedure

### 1.1 Objectives & Methods

The primary goal of the NRSC's field testing program is to capture simultaneously the over-the-air (OTA) transmission performance of both the digital and analog portions of iBiquity's Hybrid FM IBOC system, along with associated transmission channel metrics. In practice, the testing team will do this by

- 1) setting up Hybrid IBOC transmission systems at agreed upon FM broadcast sites,
- 2) testing each IBOC broadcast site using a mobile test platform (test van) to sample over-the-air transmissions and
- 3) delivering the field test data to the designated entities for processing, analysis and archival.

FM Hybrid IBOC field test program consists of at least five test segments conducted in the areas in and surrounding San Francisco, Las Vegas, New York City and the Washington DC-Baltimore area. In this document, the phrase *test segment* connotes a self-complete suite of tests for a particular IBOC broadcast station. The IBOC station will provide the *desired* signal for most of the test segment and, in the case of compatibility tests, also will serve as an interferer to proximal analog stations.

#### 1.1.1 The Auditor

The field testing team may include an auditor who will observe the test procedures under the auspices of the ATTC. The auditor – or *Auditing Engineer* – shall be permitted access to any and all aspects of the official testing procedure. The primary role of the auditor is to verify that

- within reason and iBiquity's capabilities, the intent of the NRSC as specified in its FM Field Test Procedures are carried out,
- the field test engineers conduct procedures according to accepted engineering practice and
- the data and/or results delivered to the NRSC properly correspond to those data collected during the field tests.

The auditor also is expected to participate as a working member of the field testing team. The iBiquity test team will support and facilitate auditor participation, as this will help the auditor better understand the test processes. Auditor participation should not impede or slow the testing process except as absolutely necessary to ensure good engineering practice or to execute properly the core auditing function. The auditor may not unilaterally alter the testing process. Minor changes to testing procedure must be agreed upon by both the auditor and the testing team. Major changes must be brought before the NRSC DAB Subcommittee Steering Committee. This process is discussed in *Section 9*, below.

The ATTC shall determine the auditor's minimum witnessing requirements.

### **1.1.1.1 Other Observers**

The NRSC may send observers to witness the field test program. These observers shall be permitted to monitor all official testing activities, but shall not interfere with test procedures or in any way be allowed to compromise the function of the auditor. In some instances, the auditor and an observer may agree to work in complimentary fashion, splitting the burden of official observation. This is acceptable where the efficiency and the efficacy of the auditing process can be maintained or improved. The observers will not actively participate in testing, but will serve only in a monitoring capacity.

## **1.2 Preparation**

To ensure the field testing processes go smoothly and efficiently and also yield valid data, the testing team will carry out a set of pre-test preparations for each test segment.

General field test program preparations are

- Test platform proof-of-performance
  - subsystem tests, including instrumentation function and performance verification
  - system certification test
  - receiver antenna characterization (optional)

Test segment-specific preparations comprise

- Verification and configuration of transmission site
  - station analog and digital powers and spectral characteristics
  - program audio, including STL performance and blend parameters
- Verification and configuration of test platform
  - antenna network
  - Data acquisition automation
  - EMI/EMC
  - Data storage preparation
    - Clearing of DAQ PC hard disk space to accommodate data
    - Formatting of HI-8 tapes for the Tascam DA-98 digital audio recorder
- Review of test procedures
  - segment-specific procedures, i.e., drive routes, timetables and special station operation instructions
  - special test procedures, e.g., host and SCA compatibility tests

This document's attachments contain both general and test segment-specific procedures and information for test preparation.

## **1.3 Execution**

The field test team will conduct testing according to the requirements and instructions provided for each test type. Some test segments also may have special instructions. The

field test team will observe these for the respective test segments, as well as, document any unique circumstances on a segment-by-segment basis.

There are four types of tests – (i) transmitter characterization; (ii) drive testing for coverage and performance of digital and analog FM; and (iii) main channel and SCA compatibility testing;. The transmitter characterization takes place at or near the transmission station and includes measurements of analog FM and digital transmission powers, as well as, transmission spectral characterizations. Most of the remaining tests fall into the drive testing category. These require setting-up the mobile test platform’s automated test systems and driving prescribed test routes. All test segments contain at a minimum some drive testing of IBOC and host FM.

Main channel and SCA service compatibility tests will take place at fixed locations within test station service areas. Main channel host compatibility tests will be conducted for two of the test stations. Adjacent (main) channel compatibility will be conducted for three to five non-IBOC, FM stations that are first adjacents to an IBOC test station. In addition, the test team will execute SCA service compatibility tests at two to three IBOC test stations. The specific stations and procedural details for compatibility tests appear later in this document.

In order to ensure the safety of test data, as well as, maintain reasonable data file sizes, the test team will parse each test segment drive route (radial or loop) into sub-routes that may be tested in *one hour or less*. This limitation is critical, as it guarantees the recorded audio will not exceed the length of the digital audio recording media. Secondly, this procedure bounds the extent of data loss should the automated DAQ systems malfunction or a data file be corrupted post-test. Limiting the size of sub-tests also facilitates re-testing and regression testing should either be required.

## **1.4 Data Recording & Handling**

### **1.4.1 Automatically Recorded Data**

The field test *data acquisition (DAQ)* system produces two fundamental classes of raw data – a group of associated PC files in ASCII text file and JPG formats, and also a Modular Digital Multi-track (MDM) digital audio recording. During testing, the test automation/DAQ software produces and writes the PC data to the test PC’s hard disk. The TASCAM DA-98 records the MDM digital audio to metal HI-8 format videotape. At the end of each testing day, the test team will backup test data. PC files shall be copied to a dedicated archival directory on the DAQ PC. If available, this should be to a second, physical hard drive in the PC as opposed to merely another partition of the same physical drive already hosting the original data. The test team also will backup the PC-based data to Iomega ZIP disks.

### **1.4.2 Manually Recorded Data**

Manually recorded data are any data not produced by the test automation applications. Examples of these are recorded audio notes, written notes and printer/plotter plots. All

data, whether “official” or “anecdotal” engineering notes will be preserved, as well as, duplicated for backup.

#### ***1.4.2.1 Test Segment Notebook***

Each test segment shall have a unique notebook or set of notebooks known as the Test Segment Notebook. Wherever possible, all engineering notations about a test segment shall be entered directly into the Test Segment Notebook. The Test Segment Notebook shall be a bound, laboratory or composition-style notebook. Standard laboratory logging and record-keeping procedures shall apply to the Test Segment Notebook. Each page shall be numbered sequentially. As entries are made, each page shall be dated at the top and dated and signed by the authoring engineer at the bottom. No pages shall ever be removed from the notebook. It is to be preserved in its entirety for the test record. No marks that render unreadable any entry shall be made in the test notebook. Errors and changes must be struck out with a single line and initialed and dated by the writer if such changes are significant to recorded data.

#### ***1.4.2.2 Test Platform Notebook***

Although not required, it is advised that a dedicated Test Platform Notebook be used to document test platform configurations, characterizations, calibrations and proofs.

### **1.4.3 Data Identification**

All data will be identified using the naming conventions substantially similar to those recommended in *Section 7*.

## **Field Test Preparation**

### **1.5 Transmission Site**

#### **1.5.1 Preparation & Configuration**

At a minimum, the FM IBOC transmission site must be configured with and/or be capable of the following:

##### ***1.5.1.1 Studio Transmission Link (STL)***

The STL that supplies the audio for digital modulation must support stereophonic audio at a quality greater than or equal to 16 bits-per-channel linear (uncompressed) encoding at a 44.1 MS/s clock rate. The Supervising Engineer shall verify that the STL for the analog (FM) audio signal is in proper working order and delivering the audio performance expected by the station’s engineering staff. Any station using an STL that does not meet the prescribed performance shall be considered generally unsuitable for test recording of the received audio programming. In any such a case, analog and digital broadcast audio programming still will be recorded during field tests, however use of that test audio may be restricted to certain types of audio evaluation.

### ***1.5.1.2 RF Monitoring Points***

To permit transmission line power measurements, the station must have at least one forward power sampling point located between the analog FM transmitter and the antenna. This sample point must be located post-IBOC RF signal injection, that is, after the IBOC power combiner circuit.

It is also desirable, but not required that the digital signal path have a sample point located before the input to the IBOC power combiner. If available, this will facilitate the measurement of the digital power and determination of the Host-to-DAB power ratio.

## **1.6 Drive Test Platform**

### **1.6.1 Description**

#### ***1.6.1.1 Hardware***

Figure 1 is a block diagram of the mobile platform test infrastructure. The main hardware components of the drive test platform – *the test van* – are:

- the test receivers, both analog and digital
- an Agilent Model 8591E spectrum analyzer
- a Trimble Placer 455 GPS receiver
- the iBiquity antenna distribution network
- the controller PC (a.k.a. DAQ PC)
- a Tascam DA-98, 8-Track Modular Digital Multi-Track (MDM) recorder and a pair of Rane SM26B audio splitter/mixers for level trimming
- a CCD camera and associated camera web server
- the 12 VDC-to-115 VAC power inverter and regulated, 115 VAC-to-13.8 VDC power supply
- the van audio monitoring system

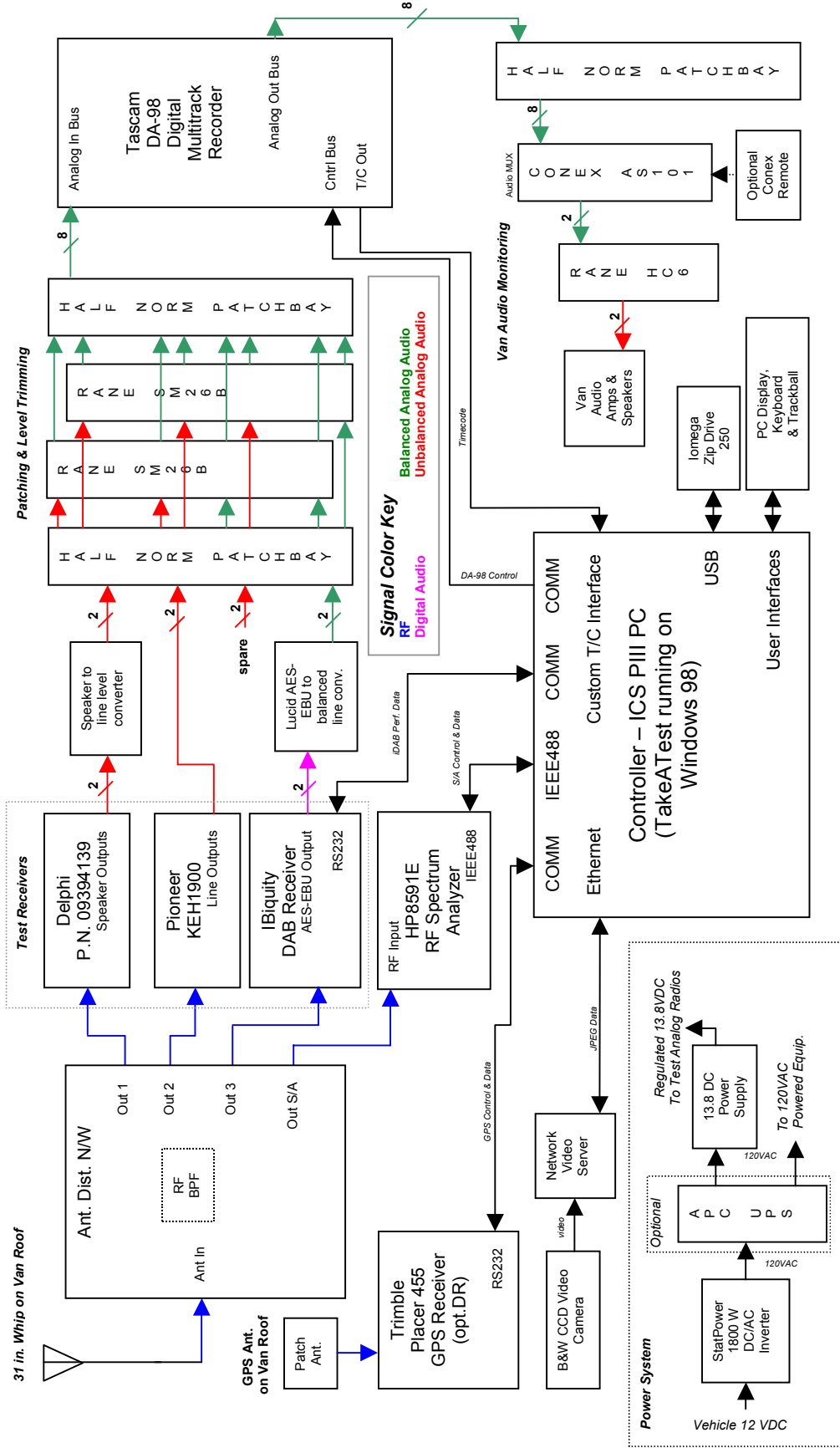

Figure 1: Mobile Test Platform Generalized Block Diagram

#### ***1.6.1.1.1 Test Receivers***

The Delphi and Pioneer analog test receivers are mounted in 19-inch rack panels and powered with regulated 13.8 VDC. The Pioneer KEH-1900 provides unbalanced, line-level audio outputs. These are connected directly to a pair of the high impedance, balanced inputs of a Rane SM-26B level trimmer via male phono-to-¼ inch phone plugs. Since the Delphi provides no line-level audio interface, it is equipped with an off-the-shelf, speaker-to-line-level adaptor module from Crutchfield. The output of this device is connected to a dedicated pair of inputs to the Rane level trimmer by male phono-to-¼ inch phone plugs.

The iBiquity digital receiver operates from the van's 115 VAC power supply. A Lucid professional quality digital-to-analog converter converts the digital receiver's audio AES-EBU output to balanced analog audio. The output of the Lucid feeds a dedicated set of Rane SM-26B inputs through male XLR-to-TRS ¼-inch phone plug cabling.

The Technics and Sony receivers are connected into the van power and audio systems only during their appropriate compatibility tests. The Technics, a home receiver, provides line-level outputs and connects to the Rane SM-26B in the same manner as the Pioneer receiver. The Sony has only a headphone jack audio output interface. However, this is easily connected into the SM-26B with an stereo adaptor cable.

The receiver outputs of the antenna distribution network connect directly to digital, Delphi and Pioneer receivers' antenna ports with appropriate RF cables and adaptors. The Technics receiver has a pigtail test cable fitted to its 75  $\Omega$  FM antenna terminals. With an extension cable, this too connects directly to receiver output of the antenna distribution network. The Sony receiver is tested using only its integral, telescoping FM antenna and, thus, requires no connection to the van antenna system.

Specific test receivers are discussed further in Section 6.

#### ***1.6.1.1.2 Spectrum Analyzer***

The spectrum analyzer is an Agilent (formerly Hewlett-Packard) model 8591E. The analyzer receives RF signals from the dedicated "spectrum analyzer" output of the antenna distribution network. The DAQ PC controls and collects data from the spectrum analyzer by way of its IEEE-488 instrumentation interface.

The spectrum analyzer is powered from the van's 115 VAC supply.

#### ***1.6.1.1.3 Global Positioning System Receiver***

The GPS receiver is a Trimble Placer 455 DR with the dead reckoning (DR) option. Physically located inside the antenna distribution network, the GPS receiver takes its power from the antenna network's internal 15 VDC supply. In the course of normal operation, the DAQ PC sends queries for a position-velocity solution over an RS-232 connection to the receiver. The Placer 455 responds by returning the solution back over

the serial interface. The ASCII response string contains latitude, longitude, velocity, GPS time, receiver mode and a freshness datum. This last piece of information is a simple indication of the data's disposition and age.

In its original configuration, the GPS receiver operated in conjunction with a DCI differential GPS receiver to improve its positional accuracy over that available for commercial service. However, the differential receiver is no longer necessary to realize increased accuracy, as the US government has turned off the GPS dithering.

The dead reckoning feature of the Trimble receiver allows it to estimate position in between full satellite constellation acquisitions. This option is not used for this testing program.

#### ***1.6.1.1.4 Antenna Distribution Network***

Attachment D shows several possibilities for antenna splitting to the radios and spectrum analyzer. Figure D1 shows the original AAN1 splitting network installed in each van. This is an active splitter designed to maintain good noise performance to any radio with a noise figure of 10 dB or greater, as well as, provide good input intercept (non-linear) performance in strong signal areas. Simpler topology, improved performance designs appear in Figures D2 and D3. Network AAN3 of Figure D3 offers the advantage of RF bandpass protection for the amplifier and test receivers from strong signals more than five channels ( $\pm 1$  MHz) away from the desired signal. The RF bandpass is a custom filter for each test segment, centered on the desired IBOC station. AAN3 degrades the noise figure of a 10 dB noise figure receiver by slightly more than 2 dB. Given the receiver path input IP3 and insertion gain of the AAN3 are slightly better than 20 dBm and close to 0 dB, respectively, it is very unlikely that this network will degrade the IM or blocking performances of any commercial receiver it feeds. *AAN3 is the recommended antenna splitting network for most of these field tests.* In areas where extremely high signals in or near the desired channel may cause AAN3 or the test receivers to overload, it is recommended that appropriate attenuation be added between the antenna and the input to AAN3.

PAN1 is a four-way passive splitting network that offers the principle advantage of the best linear performance of all splitters shown. In order to preserve linearity, PAN1's design contains no active elements. The RF bandpass filter feeds all radios. The trade-off of PAN1 is its poorer noise performance. It will lower the sensitivity of a receiver from 6 to 7.5 dB depending upon from which output port a receiver obtains its signal. In high ambient noise environments, this limitation is not an issue. However, this network is not a good choice for testing in edge-of-coverage areas that are in low ambient RF noise regions, e.g., rural areas.

All test vans are equipped with network AAN3. This network is designed and built for easy field re-configuration into a variety of active and passive splitter architectures. Also included in the AAN3 rack-mountable enclosure are a spare amplifier module, a two-branch passive power splitter, the Trimble Placer 455 GPS receiver and a 115 VAC-to-15 VDC regulated power supply for all active components.

### **1.6.1.1.5 DAQ PC**

The DAQ PC controls the operation of and collects data from all other measurement equipment except the antenna distribution network. Its chassis is a heavy-duty, industrialized design from ICS, incorporating disk drive shock mounting and extensive EMI/EMC-shielding. The main processor is an Intel Pentium II, running at a clock rate between 300 and 500 MHz.

All DAQ PCs use the Microsoft Windows 98 operating system. User interfaces for the PC are the typical monitor, keyboard and, as the pointing device, mouse or trackball.

The digital radio, GPS receiver and MDM recorder deliver data to the DAQ PC via RS-232. The spectrum analyzer operates over the IEEE-488 (GPIB) instrumentation bus. The CCD camera by way of its network camera server delivers stop-action JPEG images to the DAQ PC via Ethernet and TCP/IP.

### **1.6.1.1.6 Digital Audio Recording System**

The digital audio recording system includes two Rane SM-26B splitter/mixers, a half-normalled, balanced ¼ -inch patchbay, a Tascam DA-98 Modular Digital Multitrack recorder and a SMPTE timecode to RS-232 interface converter.

As described in the test receiver section above, all receiver outputs feed dedicated channels in the Rane SM-26Bs, which are set up as straight-through audio trimming blocks, each channel isolated from all others. The right and left channels from each radio are paired into and out of adjacent trimming sections, arranged either side-by-side or top-and-bottom. The outputs from each SM-26B section are balanced. Each drives one of the eight, available DA-98 balanced, analog audio inputs as indicated in Figure 1. The eight, balanced outputs from the DA-98 supply the input section of the Conex AS101, which is the van's audio system multiplexer. From Figure 1, note that half-normalled patchbay sections permit breakout, splitting and substitution of audio signals immediately before the SM-26B trimmers, between the SM-26Bs and the DA-98 inputs and at the DA-98 outputs. These patch points allow access for performance verification, troubleshooting and easy receiver substitution during certain tests, such as SCA compatibility.

To synchronize the digital audio recordings with other field test data, the DAQ PC records the SMPTE timecode<sup>1</sup> from the DA-98. An iBiquity-designed converter module performs electrical and protocol conversions to translate the DA-98 timecode into an RS-232 UART-compatible signal for the DAQ PC. For powering and placement convenience, the module is installed in a PCI slot of the DAQ PC. A custom cable kit connects the converter to the timecode output on the DA-98 rear panel and also to a serial port on the rear DAQ PC. An ancillary function of the timecode converter is remote control of the DA-98 transport, but this feature is not used, as it is not yet fully tested.

---

<sup>1</sup> As configured, the DA-98 does not supply actual SMPTE timecode, but instead, it provides elapsed tape time in SMPTE timecode format. For these test purposes, the difference is not significant, and the terms *elapsed (tape) time*, *SMPTE timecode* and *timecode* are used interchangeably.

The DA-98 recorder was chosen for this mobile recording application for numerous reasons. In particular,

- It has a recording mode confidence head to allow immediate playback of the actual audio captured on tape. This allows real time verification of recording operation.
- It can record at both 44.1 and 48 kS/s rates.
- It has self-contained performance monitoring modes, e.g., error rate indications, head condition monitoring and maintenance logging
- The recording medium – Hi-8 metal videotape – is reasonably available, durable and compact.
- Direct-to-PC interfaces are available for direct-to-PC recording (simultaneous with taping) and direct digital audio transfer.

The capabilities and features of the DA-98 are extensive and not always obvious, especially to those outside the professional audio industry. All field test engineers should review the *Tascam DA-98 User Manual* to ensure proper use and understanding of the unit.

#### ***1.6.1.1.7 CCD Camera***

Facing forward on its mount at the front of the van, the CCD camera captures periodic images of the field test environment for storage with correlated field test data. The camera produces compressed JPEG image files, which it sends to its associated network camera server. The server encapsulates the image files in IP broadcast packets and “pushes” these out over its Ethernet interface, where the co-networked DAQ PC waits ready to receive them.

The camera may be either color or black-and-white (B&W). Currently, only B&W cameras are used, as B&W images have significantly smaller file sizes than do color images. This helps reduce data storage and transfer requirements.

#### ***1.6.1.1.8 Power Supply Systems***

Each component of the field test DAQ platform has powering requirements for either 115 VAC or automotive DC, nominally 12 VDC. A Statpower 1800 DC-to-AC inverter provides 115 VDC. Depending upon the van configuration, the inverter receives its input power either from the vehicle’s main battery over a low gauge, dedicated cable pair or via direct connection to a dedicated, deep-cycle battery that is tied into the vehicle’s charging system.

All test equipment and radios except for the automobile test receivers and the audio power amplifier operate from 115 VAC<sup>2</sup>. The auto receivers could operate directly from the vehicle DC supply. Nevertheless, there is the possibility that the voltage fluctuations and conducted EMI typical of a vehicular electrical system could cause substandard or inconsistent performance in these radios. To avoid these potential problems, the van is equipped with an Astron *115 VAC to 13.8 VDC* regulated supply. This provides the test

---

<sup>2</sup> The GPS system also requires automobile voltages, receives its power from the antenna distribution network’s internal supply, which converts *115 VAC to 15 VDC*.

radios a stable, clean power source, well isolated from the van's electrical system. The Astron supply draws its power from the Statpower inverter.

As its operation is not critical to testing, the audio power amplifier draws its power from the vehicular 12 VDC supply.

#### ***1.6.1.1.9 Audio Monitoring System***

The in-van audio monitoring system consists of a Conex AS101 audio multiplexer, a Rane HC-6 headphone console, a multi-channel audio power amplifier and loudspeakers. The AS101 selects the audio from one receiver at a time for routing to the HC-6. The channel 1 control on the HC-6 adjusts the level of the audio fed to the audio power amplifier and speakers. HC-6 channels 2 through 6 controls set audio levels fed to their corresponding headphone jacks.

The audio monitoring equipment serves only to provide the test team with convenient monitoring of any receiver's audio during data collection. Other than this, the audio monitor system has no official test or evaluation purpose.

#### ***1.6.1.1.10 Test Automation Software***

The test automation software, *TakeATest*, is a stand-alone, executable program written in Microsoft VisualBasic that runs under Windows 98 on the DAQ PC. TakeATest completely controls the performance elements of digital field testing. TakeATest can query and/or control an Agilent HP8591E spectrum analyzer, a Tascam DA-98, a Trimble Placer 455 GPS receiver, iBiquity digital receiver and a networked JPG image camera server.

In addition to the executable file, the other main elements of TakeATest are the initialization files, IniSet.ini and Mese.ini, the video transfer file, CamPic.jpg and several bitmap files located in the root C directory, C:\. As for any program that relies on initialization (INI) files, there is always a danger that corruption of INI files during program crash will render the program useless. To guard against this, TakeATest is always installed with a set of read-only INI files located in a dedicated backup folder (directory). If this folder is not obvious, the operator can find these back-up files by doing a find operation on the file names IniSet or Mese.

TakeATest's graphical-user-interface (GUI), shown in Attachment B, is relatively straightforward in concept.

### **1.6.2 Preparation**

#### ***1.6.2.1.1 Test Receivers***

#### ***1.6.2.1.2 Pre-Test Characterization & Set-up***

#### ***1.6.2.1.3 FM Receivers***

All FM test receivers require pre-field test characterization as specified by the NRSC. NRSC sponsor CEA has arranged for receiver characterization testing with an independent laboratory. Each characterized receiver will bear an identification number. This identification number shall be recorded with the field test data so field performance of any analog receiver may be corroborated and/or compared to its laboratory characterization. Attachment F contains a table detailing identification, characterization status and installation location for each field test analog receiver.

Specific characterization testing information is available in documents located on the NRSC's website.

#### ***1.6.2.1.4 Digital Receiver***

Each digital receiver will be characterized and declared ready for testing by iBiquity engineering prior to any field testing. No changes to a digital receiver shall be permitted during field testing unless authorized by the field test Engineering Manager or Program Manager. Test data and an explanation of modifications or repairs must accompany any changes that are made.

Attachment F contains a table detailing identification, characterization status and installation location for each field test digital receiver.

#### ***1.6.2.1.5 Test Van Subsystem Characterization & Proofs***

The test team must conduct mobile test platform (test van) subsystem characterization and proofing at least once during the field test program to ensure proper configuration and performance of the measurement components. Should any subsystem be altered or replaced during the course of the field test program, that subsystem and any other affected subsystems must be re-proofed. It is recommended that test van subsystem proofing be done *prior to* the first official field test done with a mobile test platform. This will eliminate the need for re-testing of a test segment should the subsystem proof indicate questionable test van performance. Further, as configurations may differ slightly from test van to test van, each van requires separate proofing.

Periodic re-proofing of the mobile test platform subsystems is advised to ensure consistency of measurement performance. All proof data shall be logged in a laboratory notebook, preferably the Test Platform Notebook.

#### ***1.6.2.1.6 Antenna System Tests***

The van antenna, its feed cable and the antenna distribution system comprise the mobile test platform's antenna systems. As would be expected, the antenna transforms the radiated FM-band signal to a transmission line signal for routing to receivers via coaxial feed cable. The antenna network may be one of several designs, active or passive, the goal of which is to power split the antenna feed signal for use by the test radios and test instrumentation. Characterization of the antenna and distribution systems is necessary to understand performance of the mobile test platform.

#### ***1.6.2.1.7 Antenna Pattern Characterization***

All test vans use a simple automobile-style whip antenna and feed to the antenna-splitting network. This 31 inch, single-element, monopole-over-groundplane arrangement provides reception substantially similar to a typical automotive antenna, though probably with better horizontal omni-directionality. This is because each van monopole is located close to the center of its van's roof, providing at least 30 inches of unbroken groundplane in any horizontal direction from the base of the antenna. The simplicity of this configuration means the antenna will provide very close to 0 dB dipole, vertically polarized gain at low to medium elevation angles for any azimuth. Given this straightforward design, there is little concern that the van antennas provide any significant advantage or disadvantage to either the analog or IBOC reception. Therefore, range calibration of van antennas is not crucial, especially as the coverage and performance of the analog and digital systems are compared using the same transmission location, same center frequency and same receiver antenna at all times. While formal antenna pattern characterization is not required, it is recommended that the test engineering team check the gain of the van antenna by comparing received signal strengths against expected signal strengths during test drives. This may be done by comparing averaged receiver signal power data against levels predicted by one of the commercial propagation prediction applications (e.g., ComStudy).

#### ***1.6.2.1.8 Antenna Distribution Proof***

All antenna distribution networks shall be characterized in the laboratory for insertion loss/gain from the antenna input to all ports. If the antenna distribution network contains any active elements, e.g., amplifiers, the network shall also be characterized for third-order input intercept performance. These characterizations shall be done across the FM band.

During testing, the configuration of the antenna distribution network may change to accommodate local conditions such as high signal levels. At the start of a test segment, and at any point where the network configuration is changed, it is prudent to do a rough gain check in the new configuration to ensure correct interconnections have been made. This may be done from a fixed location by using the spectrum analyzer to measure the power of a convenient, off-air signal directly from the test antenna. The antenna should then be connected to the input of the antenna distribution network and the analyzer used to check the power of the same signal from each antenna distribution network output port being used in the new configuration. Measured insertion losses/gains should be consistent with values obtained during the antenna network calibration. All checks should be documented in the Test Platform Notebook, or a Test Segment Notebook.

#### ***1.6.2.1.9 GPS System Tests***

The test team will locate Drive Test Platform at a position of known geographical coordinates. The platform's GPS receiver shall provide the correct latitude and longitude with an error of less than 20 meters. GPS operation also may be verified using DeLorme Street Atlas or iBiquity's DataView<sup>3</sup> program to plot test route data against a known good map.

#### ***1.6.2.1.10 Spectrum Analysis***

Using an RF signal source, the test team will inject a set of RF test signals into the input of the antenna network to test the spectrum analysis operation. All modes of spectrum analysis used in testing shall be checked to verify the analyzer never is forced into uncalibrated operation.

#### ***1.6.2.1.11 Audio Recording Subsystems Tests***

The audio recording subsystems shall be examined to ensure balanced, distortion-free recording of all audio channels for each radio under test. In particular, silent passages in recorded material from each audio source (radio) shall be checked for the presence of noise and hum. Residual hum and noise shall be no greater than -90 dB relative to full scale, A-weighted RMS, or -80 dB relative to full scale, A-weighted Quasi-Peak measured from the point of audio signal input (from the test radios) to recorded digital audio tape. If tests are made using a reference level below full scale, the required performance is de-rated by the decibel difference between full scale and the test reference level. For example, if the test reference level is -12 dBFS, then the maximum residual hum and noise shall be -78 dB A-weighted RMS or -68 dB A-weighted Quasi-Peak. This test does not include noise produced by the test radios nor apply to the in-van audio monitoring system after the DA-98 digital audio recorder. The recommended instrument for this test is the Audio Precision model System I (or System II) equipped with A-weighted audio filtering and Quasi-Peak velocity metering.

#### ***1.6.2.1.12 Data Logging Tests***

The automated field testing program, a.k.a., TakeATest, shall be checked for proper data acquisition and storage. To do this, two verification steps are prescribed:

- Examine the data display capabilities of TakeATest in the pre-recording mode. The control panel of TakeATest displays indicators for all data recording modes that are active. The test engineers should be able to verify acquisition of camera data, GPS data, spectral data and digital radio blend counter and analog/digital state data.
- Initiate TakeATest recording mode and store test data to a file. After storage of several cycles of test data, end the recording mode. Using a text editor, open the data file and manually verify that contents of the file include all

---

<sup>3</sup> DataView is an iBiquity-developed application that can directly playback TakeATest data files. It presents the spectral plots, GPS-derived route maps, digital audio recorder timecode, camera images and radio performance data in stop-action format, allowing for frame-by-frame review of a test run.

forms of data and that these data match the test conditions during the recording. Using provided conversion programs, the data file may be converted to a tab-delimited text file containing GPS and radio performance data. In this format, it is possible to import lat/lon-keyed data into a PC-based mapping program, such as Delorme Street Atlas for review.

Alternatively, the raw data file, directly from TakeATest may be “played back” using iBiquity’s DataView program.

### ***1.6.2.1.13 Electromagnetic Interference Checks***

Each mobile test platform, including the van, instrumentation, power sources and the test radios themselves must undergo testing for local generation of EMI that may cause degradation to the performance of the test radios. This testing is usually done in several steps. The first step is to check the FM band for the presence of interference using a spectrum analyzer connected to the van antenna. Unfortunately, spectrum analyzers do not possess the same sensitivity (low noise figure) as the receivers being tested. This test will identify only the more blatant EMI offenders.

Two approaches to enhancing spectrum analyzer EMI testing capabilities are possible – the addition of an LNA before the spectrum analyzer’s RF input and the use of a close-field probing antenna. The former method will lower the spectrum analyzer’s effective noise floor, making it much more sensitive to low-level signals and interference. However, the analyzer may not yet be sensitive enough to “hear what the radio hears.” Using a close-field probe – e.g., an electrically shielded magnetic loop or small, amplified dipole, will not actually increase the analyzer’s sensitivity, but it will facilitate the isolation of each potential radiated interference source in the van. This helps lead to clear identification of any and all FM-band emitters. Assiduous observation by this method will usually reveal all *potential* interferers, but many of these will have no significance to the receivers’ performances. The importance of close field probing is the ability to absolutely identify all in-band EMI generators.

After identifying potential interferers, the next step is to evaluate the effect each has upon receiver operation. The team can best do this by testing in an edge-of-coverage over-the-air signal situation and monitoring receiver performance parameters (e.g., audio quality and/or block-error-rates) as each potential in-band emitter is turned *ON* and *OFF* one at a time. Note: this test *must* be done over-the-air. Testing over a coaxial connection between a transmitter and the target receiver is not a critical, real world test, as most in-field EMI problems are the result of radiated, *not* conducted interference.

If threshold sensitivity of any radio – analog or digital – is degraded by more than 1 dB with all van equipment *ON* versus all van equipment *OFF* (except radio under test, preferably DC power source and audio test gear, then it is likely EMI remediation will be necessary. A measurable loss of full audio quality<sup>4</sup> in any test radio due to van instrumentation or power supply operation also may indicate EMI degradation.

---

<sup>4</sup> Assessing the severity of audio quality loss is left to the professional judgement of the test team.

Attachment E discusses EMI remediation. Sensitivity of an analog FM radios is typically benchmarked as the antenna input signal level versus some measure of audio quieting, signal-to-noise ratio or SINAD<sup>5</sup>. For the digital radio, sensitivity is defined as the RF signal level required for a predetermined BLER performance. For a comparative measure of sensitivity, it is recommended that

- Analog receivers should be tested for RF input level to achieve a stereo audio 50 dB (RMS) signal-to-noise ratio or 40 dB (AWQP<sup>6</sup>) signal-to-noise ratio. Alternatively, a 20 dB SINAD (AWQP) audio performance level may be used. If the sensitivity is done using analog receivers, it is probably only possible to make the measurement using a local, low powered FM transmitter in order to be able to control the audio modulation. This is difficult measurement to conduct, as it must be done in an area of extremely low RF background noise.
- The digital receiver should be tested for RF input level required to achieve a fixed modem block-error-rate of 1 to 10 %. As with an analog receiver, digital receiver testing must be done in an area of low RF background noise. But unlike the case of the analog test signal, the digital transmitter modulation may be used without any content change, making this method more easily executed in the field.

Finally, if the sensitivity of the spectrum analyzer does not seem to show any EMI, yet all other signs indicate in-band, self-interference, two things may help: First, monitor the IF signal of one of the receivers to see if the interference is visible there. If so, proceed to switching local equipment *ON* and *OFF* to identify the EMI offenders. Second, conduct a wideband spectral analysis on the signal from the antenna to determine the possibility of intermodulation interference.

#### ***1.6.2.1.14 Mobile Test Platform System Certification***

The goal of mobile test platform certification is to ensure the all radio receivers perform to expected levels when installed in the test van along with the entire suite of required test and measurement instrumentation. To this end, the following procedures shall be conducted to guarantee proper, integrated performance of the test receivers and mobile test platform. All mobile test platform system certification tests use coaxial-cabled RF test signal injection.

Mobile Test Platform System Certification will be conducted using all receivers that will be connected to the van's antenna system and/or power supply. All equipment used for field tests, including all test radios, shall be powered during certification tests.

#### ***1.6.2.1.15 Analog Receiver Tests***

The analog receiver tests demonstrate that test van installation does not significantly alter the performance characteristics of the test radios as compared to the laboratory

---

<sup>5</sup> SINAD is a signal-to-noise type measurement where the desired signal is notched filtered from the receiver's audio signal instead of being removed from the test transmitter modulation, as is done for signal-to-noise testing. The SINAD ratio is defined as (S**I**gnal+N**O**ise+D**I**stortion)/(N**O**ise+D**I**stortion).

<sup>6</sup> **A-Weighted, Quasi-Peak**, a combined filtering and metering ballistics setting that better represents human audio perception.

environment. These tests ensure mid-level signal performance of the van's RF distribution network and audio signal path integrity from each receiver's audio output to the digital audio recorder's inputs. The test engineers will set up an FM transmission test set to provide an RF level of  $-62$  dBm to each analog radio under test. The FM transmission test source (*FM generator*) shall be configured for 75 microsecond pre-emphasis and stereo transmission. The left and right audio channels of the FM generator shall be capable of independent injection of test tones, so that either one, both or none of the audio channels may audio carry test signals. Reference levels for all audio measurements shall be 100% of the FCC-permitted modulation into the left, right or both channels.

For this test suite, an integrated audio generator and analysis test set such as the Audio Precision System II is recommended. This audio analyzer's generator shall inject test audio into the FM generator's left and right modulation inputs as appropriate to each test. For all tests, audio outputs from the mobile test platform shall be sampled via the patchbay at the output of the DA-98 digital audio recorder. All outputs of the DA-98 shall be set to *input monitor mode* for these tests. The following measurements shall be conducted for each analog receiver:

#### ***1.6.2.1.16 Audio Hum and Noise***

A-weighted, quasi-peak and A-weighted, RMS measurement of either left or right channel alone. Tested channel modulation reference is a 1 kHz tone at 100% permitted modulation deviation. The audio channel not being measured shall be un-modulated.

#### ***1.6.2.1.17 Audio Total Harmonic Distortion and Noise***

A-weighted, quasi-peak and A-weighted, RMS measurement of either left or right channel alone. Tested channel modulation reference is a 1 kHz tone at 100% permitted modulation. The audio channel not being measured shall be un-modulated.

#### ***1.6.2.1.18 Audio Stereo Channel Separation***

A-weighted, quasi-peak and A-weighted, RMS measurement of crosstalk either left channel to right channel or right to left. Modulated channel reference is a 1 kHz tone at 100% permitted modulation. The separation measurement is taken from the un-modulated channel, e.g., modulate right only, measure separation from left.

#### ***1.6.2.1.19 Digital Receiver Tests***

The digital receiver shall be tested in both analog and digital modes. The analog mode tests shall be conducted in the same manner in which the analog receivers are tested. That is, by use of an FM transmission test set and an audio analysis test set in the manner described in section 5.2.2.3.1 above. In order to ensure the digital receiver is in analog reception mode, an analog-only RF test signal shall be supplied to the receiver.

Digital mode tests may be conducted using test signals from an IBOC exciter and FM transmission test set. These signals are amplitude scaled and combined to create a hybrid IBOC test signal. The combining ratio of the analog and digital portions of the hybrid signal shall be set to the same ratio as used for the lab and field tests. The hybrid signal

will be injected into the antenna distribution network and received by the digital receiver via its designated port.

#### ***1.6.2.1.20 Analog Mode FM Audio Hum and Noise***

A-weighted, quasi-peak and A-weighted, RMS measurement of either left or right channel alone. Tested channel modulation reference is a 1 kHz tone at 100% permitted modulation. The audio channel not being measured shall be un-modulated.

#### ***1.6.2.1.21 Analog Mode FM Audio Total Harmonic Distortion and Noise***

A-weighted, quasi-peak and A-weighted, RMS measurement of either left or right channel alone. Tested channel modulation reference is a 1 kHz tone at 100% permitted modulation. The audio channel not being measured shall be un-modulated.

#### ***1.6.2.1.22 Analog Mode FM Audio Stereo Channel Separation***

A-weighted, quasi-peak and A-weighted, RMS measurement of either left to right channel or right to left channel. Modulated channel reference is a 1 kHz tone at 100% permitted modulation. The separation measurement is taken from the un-modulated channel, e.g., modulate right only, measure separation from left.

#### ***1.6.2.1.23 Digital Mode Block-Error-Rate***

Hybrid IBOC RF level injected at the input of the antenna distribution network versus receiver block-error-rate (BLER), as read from the receiver. Recommended tests are: long-term BLER at a  $-62$  dBm hybrid signal RF input to check for irreducible error rate (also known as *error leakage*) and RF level versus BLER for BLER near 1% and 10%.

### **1.7 Calibration of Test Equipment**

All test equipment that is part of the digital station or mobile test platform or used to test any systems or components of either shall be calibrated to acceptable test and measurement industry standards. Specifically, all equipment that is subject to calibration cycles shall be maintained per the manufacturers' recommendations. Each item of such equipment must bear a calibration label evidencing valid and current calibration status. No piece of test equipment that is due for calibration or has no evidence of proper calibration status may be used for official measurements. Further, any piece of test equipment subject to a calibration schedule shall be re-calibrated if exposed to extreme physical or electrical conditions that could possibly alter that instrument's measurement accuracy.

## **Field Test Execution**

### **1.8 Station Characterization**

As described in the Test Group A of the NRSC's *IBOC Field Test Procedures – FM Band*, the test team will record several power and spectral measurements to verify characteristics of the FM IBOC transmission signal. Table 1 details settings and conditions for the station characterization.

Measurement	Description	Test Point	Test Equipment	Schedule
Station analog FM power, see NRSC Procedures section A.1.1	Station forward power with and without digital signal is measured at nearest available point to final feed to antenna using an RF average power meter. Forward power as measured by station equipment also shall be noted.	Antenna Feed Sample Point, station metering	Power meter and station equipment	At start of segment and as required should TX configuration change
Station digital signal power (digital-to-analog signal power ratio), see NRSC Procedures section A.1.2	Digital power is measured relative to total power using a spectrum analyzer. Total TX power reference is determined using the spectrum analyzer centered on station frequency and set to 1 MHz RBW and 30 Hz to 1kHz (or auto) VBW. A <b>normal marker</b> set to the center of the channel should be used to read the Total TX Power. Video averaging of 25 to 100 is recommended. Digital power is estimated using 1 kHz RBW, 100 to 1 kHz (or auto) VBW and a <b>noise marker</b> centered in each digital sideband (+/- 165 kHz from center frequency). Video averaging of 25 to 100 is recommended. Sideband powers are integrated over 70 kHz bandwidth each and added to determine total digital power. Digital-to-analog power ratio = $10\log(\text{linear Digital Power}) - 10\log[(\text{linear Total Power} - \text{linear Digital Power})]$ (dB)	Antenna Feed Sample Point	Spectrum analyzer	At start of segment and daily

Measurement	Description	Test Point	Test Equipment	Schedule
Station Occupied BW – averaged spectrum, see NRSC Procedures A.3	Station spectrum recorded analog only (without digital signal), centered on channel, 500 kHz span, 1 kHz RBW, 1 kHz VBW, 10 dB/div, video averaged 100 times	Antenna Feed Sample Point	Spectrum analyzer	At start of segment and as required should TX configuration change
Station Occupied BW – max hold spectrum, see NRSC Procedures A.3	Station spectrum recorded analog only (without digital signal), centered on channel, 500 kHz span, 1 kHz RBW, 1 kHz VBW, 10 dB/div, max hold trace for 150 seconds (about 100 sweeps)	Antenna Feed Sample Point	Spectrum analyzer	At start of segment and as required should TX configuration change
Wide Spectral Sweep, see NRSC Procedures A.2	Station spectrum recorded with and without digital signal, centered on channel, 2 MHz span, 1 kHz RBW, 100 Hz VBW, 10 dB/div, video averaged 5 to 10 sweeps	Antenna Feed Sample Point	Spectrum analyzer	At start of segment and daily
Narrow Spectral Sweep, see NRSC Procedures A.2	Station spectrum recorded with and without digital signal, centered on channel, 500 kHz span, 1 kHz RBW, 30 Hz VBW, 10 dB/div, video averaged 5 to 10 sweeps	Antenna Feed Sample Point	Spectrum analyzer	At start of segment and daily

**Table 1: Transmission Site Measurements**

### 1.8.1 Off-Air Station Characterization

For some stations, the transmission site may not present reasonable daily access, making daily measurements of spectrum and digital-to-analog power ratios unreasonably difficult and/or lengthy. For these stations, measurements after the first day may be conducted from a fixed, line-of-sight location within 3 to 5 kilometers of the transmitter. When these remote spectral checks are done, care must be taken to ensure that the test location is not subject to multipath reception or interference, either of which will corrupt the measurement.

To illustrate the issue of interference, consider a co-frequency, broadband interferer whose received power in the measurement bandwidth is 15 dB below a DAB sideband. Let this interfering signal's power spectral density (PSD) characteristic be similar to, but uncorrelated with the DAB sideband. Such an interferer in the presence of the DAB sideband may not be easily discernable on the spectrum analyzer, yet would cause the measurable power anywhere within the DAB signal to be more than +0.3 dB in error. At a ratio of 20 dB below the DAB power, the error would drop to less than +0.1 dB. In practice, the most likely off-air interferer to a DAB sideband would be a first adjacent station. To ensure good digital sideband measurement accuracy in the presence of first adjacent interference, the test team should observe the following guidelines:

- For an averaged, 1 kHz RBW measurement in the center of a DAB sideband ( $\pm 165$  kHz from center of channel), the total first adjacent interfering power in the 1 kHz region of the point of measurement must be at least 20 dB below the DAB sideband power. Considering an aggressively modulated first adjacent, which is the worst case measurement situation: **The averaged PSD “peak” of the first adjacent interferer should be at least 10 dB below the “flat-top” of the pertinent digital sideband PSD.** As shown in Figure 2, the location of this interfering FM station's peak will coincide with the outer edge of the digital sideband. Should the PSD of the first adjacent interferer be difficult to discern, it is recommended that the DAB sidebands be turned off to check the interference characteristic. Moreover, if the test engineer must turn off the DAB sideband for this check, it is best to ensure directly that the interfering first adjacent PSD is indeed the 20 dB below the DAB PSD envelope at the point of measurement.

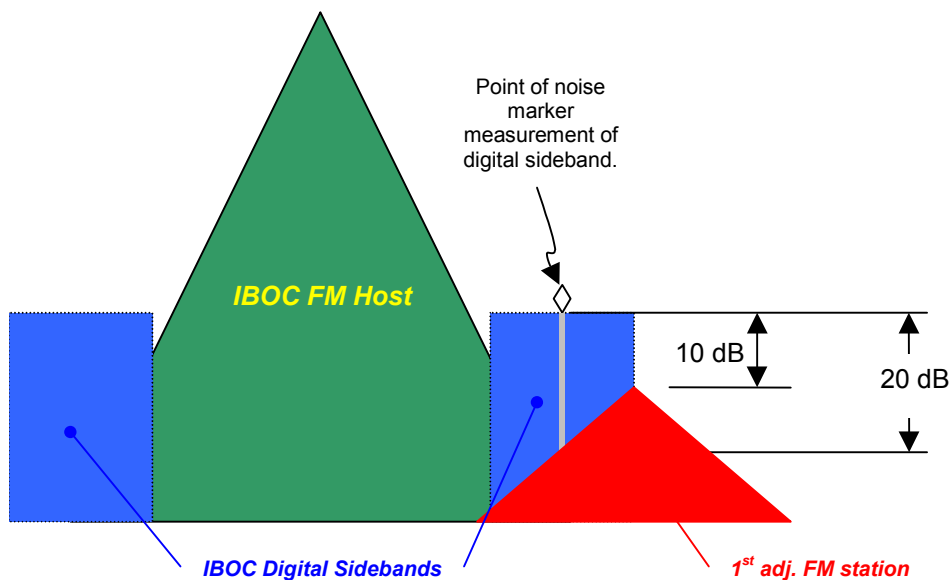

**Figure 2: Permissible 1<sup>st</sup> Adjacent Interference Levels for Off-Air DAB Power Ratio Measurement**

There is no particular methodology used in checking for specular fading, other than examining the time-averaged display of the spectrum to ensure there are no frequency-dependent anomalies in the host and DAB sideband power spectral densities. This includes tilt in the digital sidebands and asymmetries in either digital or analog signal components.

Finally, test engineers must be certain that there is no overload of the spectrum analyzer or amplifiers placed in-line before the spectrum analyzer during off-air station characterization. All measurement components must operate in their linear regions to ensure accurate measurement of a station's IBOC parameters. Particular attention must be paid to the possibilities of compression if the mobile test platform's active antenna network is used as a pre-amplifier to the spectrum analyzer. This network cannot be guaranteed to operate linearly for a total signal power greater than  $-10$  dBm at its input port (from antenna)<sup>7</sup>. It is recommended that no pre-amplification be used ahead of the spectrum analyzer for this type of off-air station characterization.

### 1.9 Performance Tests

Fundamentally, performance testing consists of driving the mobile testing platform over the prescribed testing routes and recording these data:

1. Audio from the digital receiver and the NRSC-designated analog FM receivers
2. Test telemetry from the digital receiver, including blend counter, analog/digital indicator, block errors versus total block counts
3. Position location information from a GPS receiver
4. Wide and narrow band spectral information in the FM band
5. A stop-action photographic record of the test route

The test application, *TakeATest* (TAT2v2) executes and controls the acquisition of all data. It is the responsibility of the testing team to initialize and start the testing application, start the digital audio recorder and correctly drive the test routes.

A key element of the testing is setup of *TakeATest*'s acquisition cycle time and parameter settings for the spectrum analyzer. The default spectrum analyzer measurement sequence appears in Table 2.

---

<sup>7</sup> This figure applies to antenna networks AAN2 and AAN3 as described in Attachment D. For antenna network AAN1 the input level should be below  $-20$  dBm for guaranteed linearity.

Test Sequence Number	1	2	3	4
Center Frequency (MHz)	IBOC Station CF	IBOC Station CF	IBOC Station CF	98.0 MHz
Span (kHz)	2000	500	2000	5000 or 20,000
RBW (kHz)	30	1	30	30
VBW (kHz)	1	1	1	3
Video Averaging	Off	Off	Off	Off
Reference Level (dBm)	As Required	As Required	As Required	As Required
Measurement Time (s)	2	2	2	2
Loops	4	1	4	1

**Table 2: Spectrum Analyzer Measurement Settings for the TakeATest DAQ application.**

By executing the cycle of measurements shown in Table 2, the mobile test platform samples specific aspects of the RF signals seen by the test radios. Primary among these signal characterizations is the desired and nearby adjacent channel signal levels. For this measurement, a span of 2 MHz centered on the desired signal frequency ensures the spectral sweep can capture all significant adjacent signals. The choice of 30 kHz resolution bandwidth (RBW) and 1 kHz video bandwidth (VBW) may seem excessively wide to obtain good spectral detail, however, these bandwidths permit the spectrum analyzer to complete the 2 MHz sweep in under 200 milliseconds. This permits nearly simultaneous capturing of desired and adjacent power level information while still preserving some of the sweep's spectral detail.

In order to gather some more detailed spectral information – especially in the vicinity of the digital sidebands, the test system also takes 500 kHz span sweeps at 1 kHz RBW and 1 kHz VBW. Finally, a wide – 5 to 20 MHz span – sweep of the entire FM band allows detection of strong FM signal that may induce blocking or intermodulation desensitization of the test receivers.

As indicated in Table 2, four 2 MHz span sweeps, one 500 kHz span sweep, four 2 MHz span sweeps and finally one 20 MHz span sweep comprise one, ten step measurement cycle. This cycle repeats continuously throughout a drive test. The frequency of particular spectral sweeps within the cycle indicates the relative importance and the temporal need for each type. It is important that this measurement sequence be followed.

### 1.9.1 Performance Test Receivers

In addition to the digital receiver, the audio from two additional test receivers will be recorded during field testing. These are:

- Delphi PN 09394139 original equipment automobile receiver
- Pioneer model KEH-1900 aftermarket automobile receiver

Each receiver used in the field tests must be pre-tested and characterized for performance in cooperation with CEA. These radios shall be connected to the mobile test platform's

common receiving antenna via the antenna distribution network along with the digital radio. Identification and location details for each performance test receiver appear in Attachment F.

## 1.10 Compatibility Tests

All compatibility tests will be conducted from fixed locations in the field. The full suite of compatibility testing includes Host Compatibility, SCA Compatibility and 1<sup>st</sup>-Adjacent (Main Channel) Compatibility.

### 1.10.1 FM Host and 1<sup>st</sup> Adjacent Compatibility Tests

Host compatibility tests are to be conducted using signals from stations WETA and WPOC. For host compatibility, measurements are to be made at three locations in each station's coverage area that exhibit strong, interference-free reception to maximize the analog audio quality received by the test radios. For all test receivers, digital audio recordings shall be made of station reception with and without the DAB digital sidebands. Each recording shall capture 30 seconds of received station audio with digital sidebands, followed by 30 seconds of received station audio without digital sidebands. This cycle shall be conducted three times (repeated twice). During this measurement, RF signal spectra shall be recorded along with the digital mode signal, which shall confirm the presence and absence of the digital signal. For this test, the recommended settings on the spectrum analyzer are:

- Center frequency: center of desired channel
- Span: 1 MHz
- RBW: 3 kHz
- VBW 3 kHz
- Sweep time: automatic
- Video averaging: 25
- Reference level: as required for good dynamic range of measurement

The test automation software, *TakeATest*, may be used to record this data during compatibility measurements.

1<sup>st</sup> adjacent compatibility will be tested on WETA, WPOC and WNEW. The procedure for 1<sup>st</sup> adjacent compatibility is essentially the same as for host compatibility except that the desired station in each test will be an analog FM station to which one of the hybrid FM IBOC stations is 1<sup>st</sup> adjacent (WETA, WPOC or WNEW). The D/U ratio for 1<sup>st</sup> adjacent compatibility tests will be 6 dB. *Note that this means the IBOC station will be 6 dB lower in power than the desired analog FM station.* As in host compatibility, the desired station audio shall be recorded for three cycles of 30 seconds of digital "ON" followed by 30 seconds of digital "OFF."

All receivers with antenna port connections may be connected to the mobile test platform antenna system for the host compatibility measurement. Receivers with integral antennas shall be tested as described below.

### **1.10.1.1 Host Compatibility and 1<sup>st</sup> Adjacent Compatibility Test Receivers**

The NRSC list of receiver appears on the last page of the IBOC Field Test Procedures – FM Band. The Host and 1<sup>st</sup> Adjacent Compatibility Receivers are:

- Delphi PN 09394139 original equipment automobile receiver
- Pioneer model KEH-1900 aftermarket automobile receiver
- Technics model SA-EX140 home hi-fi receiver
- Sony model CFD-S22 portable receiver

Each receiver used in the field tests must be pre-tested and characterized for performance in cooperation with CEA (see *Section 5*). Identification and location details for each compatibility test receiver appear in Attachment F.

### **1.10.1.2 Compatibility Testing of Receivers with Integral Antennas (Sony CFD-S22 or equivalent)**

At least one of the NRSC test receivers specified for IBOC compatibility testing has an integral antenna. Typically, a radio receiver of this type is intended to operate in a freestanding configuration, powered by batteries or AC-mains and unconnected to any other equipment. To test an integral-antenna radio in a “reasonable use scenario,” no connections to its antenna system shall be permitted. This minimizes the effect the measurement may have upon the as-designed antenna system of the receiver. For the same reason, the receiver shall be powered from batteries. This will eliminate the possibility that the power cord could become an unintentional counterpoise to the radio’s antenna element. However, the counterpoise problem may yet exist, as it will be necessary to connect the digital audio recorder to the receiver’s audio (headphone) output. To minimize the RF effects of this connection, the audio cable shall be choked with a ferrite element to prevent RF signals from traveling along the cable. The ferrite element shall be formulated for effective suppression in the FM broadcast band and located as near as possible to the receiver for best RF decoupling.

This procedure shall be followed in order to sample the desired RF signal impinging upon the test portable receiver:

1. The test team will mark off an unobstructed area of ground out-of-doors that measures  $2\lambda$  by  $2\lambda$  square – where  $\lambda$  is the wavelength in freespace of the desired signal. This will be called the *test area*. See Figure 4.
2. At each of the test area’s nine vertices defined by the corners of each one- $\lambda$  square, the desired signal shall be sampled using a calibrated, test dipole antenna. The dipole shall be tuned to the desired station’s center frequency. At each vertex point, the antenna shall be supported by a non-metallic structure so that the center of the test dipole is about 1.5 meters (5 feet) above ground level. The dipole will be vertically polarized. For each vertex location, the desired and proximal undesired signals will be recorded in three spectral plots, using two different spectrum analyzer configurations. The first configuration shall enable reasonably accurate confirmation of the target

D/U ratios required for the test. For this, the IBOC signal's digital sidebands shall be turned "**OFF**" and the spectrum analyzer will be set up as follows:

- Center frequency: center of desired channel
- Span: 1000 kHz
- RBW: 100 kHz
- VBW 100 kHz
- Sweep time: automatic
- Video averaging: 100
- Reference level: as required for good dynamic range of measurement

*It is important to note that this measurement is only useful for checking 1<sup>st</sup> adjacent D/U ratios from -15 to +15 dB with approximately  $\pm 0.5$  dB accuracy. At ratios of +20 or -20 dB, the accuracy cannot be guaranteed better than  $\pm 1.5$  dB.*

The second and third spectral plots shall be made with the IBOC signal's digital sidebands turned "**OFF**" and then "**ON**", respectively. For these, the spectrum analyzer settings shall be:

- Center frequency: center of desired channel
- Span: 1000 kHz
- RBW: 3 kHz
- VBW 3 kHz
- Sweep time: automatic
- Video averaging: 25
- Reference level: as required for good dynamic range of measurement

3. The test engineer will examine the spectral sweeps to confirm the desired signal reception in the area is free of multipath and meets the signal strength and interference criteria required for the compatibility measurement.
4. After all spectral measurements are completed, the portable receiver shall be placed at the center vertex (Figure 4, position 5), at an elevation of 1.5 meters. Its antenna shall be fully extended and vertically polarized. Host compatibility recordings shall be made in accordance with the NRSC Test Procedure – that is, three cycles of 30 seconds of reception with digital sidebands "**ON**" followed by 30 seconds of reception with digital sidebands switched "**OFF**." The use of TakeATest to record the spectrum at a point further than  $2\lambda$  away from the receiver is recommended. This will correlate the on-off state of the DAB sidebands with the digital audio recorder timecode.

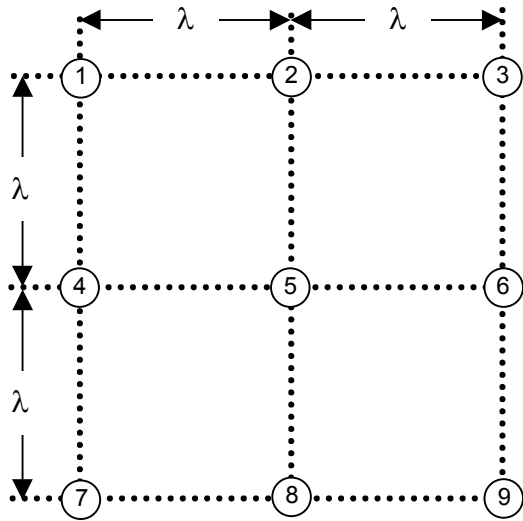

**Figure 4:  $2\lambda$  by  $2\lambda$  Measurement Grid**

### 1.10.2 SCA Compatibility Tests

SCA Compatibility Tests are executed in much the same way as Host Compatibility Tests. The primary difference is the substitution of SCA receivers for the analog FM receivers in the mobile test platform. All NRSC-designated SCA receivers are modified to accept RF input from an external, cabled source. This allows the use of the van's antenna distribution network to feed the SCA receivers. **However, it is critical to add a 1:1 RF isolation transformer between the antenna distribution signal output and the SCA receiver inputs.** This transformer guards against inadvertent shorting of some SCA receivers' internal power supplies and also prevents the creation of ground loops in the mobile test platform.

SCA compatibility will be conducted using WPOC and WD2XAB. In the case where the radio station is not supplying the needed SCA service, iBiquity will install SCA generators. For this purpose, Modulation Sciences "Sidekick" model SCA generators at both 67 kHz and 92 kHz are available from the iBiquity Warren test laboratory. Where the test station does not provide appropriate SCA program material for subsequent subjective testing, the test team install a CD player and provide high quality, monophonic speech program material such as that commercially available on "Books-on-CD." See the NRSC's document *IBOC Field Test Procedures – FM Band*, Section C2 for SCA setup parameters and testing requirements.

#### 1.10.2.1 SCA Compatibility Test Receivers

Supplied by the NRSC, these are the SCA test receivers:

*For WPOC on 93.1 MHz*

- Norver model *The Radio Talking Book* for the State of Minnesota @ 67 kHz
- Compol model SCA-8L @ 92 kHz

For *WD2XAB* on 93.5 MHz

- McMartin model TR-E5/55M @ 67 kHz
- Cosmocom model N/A @ 92 kHz

## Data Handling

### 1.11 File naming conventions

Data files, loose document pages and digital audiotapes shall be named using the formats shown below. It is important to adhere to these conventions in order to facilitate data cataloging, file sorting and user recognition of file contents.

#### 1.11.1 Data Files

Data files created by the *TakeATest* DAQ application shall be named using the form

**AAAABBBBCDDEEE.txt**

*Where,*

AAAA = The digital transmitting station's call letters

BBB = the route radial designation in degrees, or an alternative alpha-numeric abbreviation descriptive of the route

C = "a" for the first segment of a radial drive, "b" for the second segment of a radial drive and so on.

DD = a numeric designator indicating the number of re-drives of a radial. "00" for the first, "01" for the second and ...

EEE = "" for original direction of drive for a radial. "REV" for the reverse drive of a radial

#### 1.11.2 PC File Storage – Disks, Tapes and Cartridges

##### 1.11.2.1 File Storage Disks

The test team will use Iomega ZipDisks and/or CD-R disks for data archival and backup. One 250 MB Zipdisk should be capable of holding the data file contents of one, entire test segment, including flat data files from the DAQ PC, JPG camera images, spectrum analyzer images and text files of engineering comments. The naming convention for backup disks shall be of the form

**AAAA-BBBBMMYY-CC/DD-EEEEEEEE**

*Where,*

AAAA = the text "NRSC"

BBBB = the test segment station's call letters

MM = the two digit designation of the month in which the test segment began

YY = the two digit designation of the year in which the test segment began

CC/DD = is the numerical indication of the volume number CC in a total set of DD disks for the test segment.

EEEEEE = "ARCHIVE" or "COPYXYZ" as appropriate to indicate whether the disk is the official archive unit or a copy, where XYZ is the number of the copy

For example, the second of three archival disks for the test data from the KWNR segment, which began testing in January of 2001, would be:

NRSC-KWNR0101-02/03-ARCHIVE

### 1.11.3 MDM Multi-track Tapes

Digital audiotapes – either from the DA-98 or any other DAT or multi-track device will be labeled using the form

**AAAABBBCDDEEE**

*Where,*

AAAA = The digital transmitting station's call letters

BBB = the radial designation in degrees

C = "a" for the first segment of a radial drive, "b" for the second segment of a radial drive and so on.

DD = a numeric designator indicating the number of re-drives of a radial. "00" for the first, "01" for the second and so on

EEE = "" for original direction of drive for a radial. "REV" for the reverse drive of a radial

In addition, all tapes will bear a pre-printed label (supplied by tape manufacturer) indicating whether the tape is a MASTER (the original recording), a SAFETY copy or simply a COPY.

### 1.11.4 Hardcopy

Hardcopy plots from the spectrum analyzer or other image-generating device will be labeled using the form

**AAAABBCCCDEEE**

*Where,*

AAAA = The test segment's digital transmitting station's call letters

BB = the two digit number of the day of the month in which the plot was made  
 CCC= the three letter alpha abbreviation for the month in which the plot was made

D = is the alpha character to indicate the test campaign set, “A” for the first, “B” for the second series (e.g., re-test) and so on

EEE = a numeric designator indicating the sequence number for the plot in the test segment

For example, the thirty-seventh plot in the first measurement campaign of KWNR, made on the 11<sup>th</sup> of January would be designated:

KWNR11JANA037

*Since the plot designation in no way describes the contents or the conditions under which a plot is made, it is vital that a description of each plot and similar hardcopy be entered into the Test Segment Notebook along with its identifying label.*

#### **1.11.5 Miscellaneous**

Miscellaneous data in formats not described above shall be labeled in the following manner:

**AAAABBBBBBCCDDDEFFF**

*Where,*

AAAA = The test segment’s digital transmitting station’s call letters

BBBBB = is a five character description of the data format, e.g., *NOTES* or *PHOTO*

CC = the two digit number of the day of the month in which the plot was made

DDD= the three letter alpha abbreviation for the month in which the plot was made

E = is the alpha character to indicate the test campaign set, “A” for the first, “B” for the second series (e.g., re-test) and so on

FFF = a numeric designator indicating the sequence number for the plot in the test segment

### **1.12 Data Delivery, Archival and Reporting**

#### **1.12.1 Data Backup Requirements**

##### ***1.12.1.1 Daily***

At the end of each testing day, the test team will copy all new data to a safety backup ZipDisk. This disk will become the archival disk at the end of the segment. If possible, all new data also will be copied to the iBiquity server in the folder designated by test

management. It is also recommended that the test log, any hardcopy and the new entry pages in the Test Segment Notebook be copied for backup.

#### **1.12.1.2 End of Test Segment**

At the conclusion of each test segment all PC file-based test data shall be completely archived on either ZipDisk or CD-R. The first such copy will be designated the *Archive Copy*.

All digital audio recordings will be duplicated at least once either by iBiquity or ATTC. Digital audio duplications only may be done as direct digital-to-digital dubs (recordings). The original MDM recording shall be designated the *MASTER*. All copies of the *MASTER* will be designated as *SAFETY COPY*.

All other records shall be copied by appropriate reproduction methods to create safety copies.

#### **1.12.2 Data Distribution and Delivery**

At the end of each test segment, the Auditor will receive a complete set of the test segment data for delivery to the ATTC. iBiquity's senior test team member also will receive a complete set of the test segment data for delivery to either the field test Engineering Manager or the field test Program Manager. All original copies of data will be hand-carried back to iBiquity's offices. ***No original data shall be transported by any means other than hand carrying.*** Only data that are securely archived may be mailed, express mailed or similarly transported.

### **Field Test Personnel**

#### **1.13 Engineering Manager**

iBiquity's field test Engineering Manager is responsible for overall technical and administrative aspects of the test program. The Engineering Manager is Greg Nease.

#### **1.14 Program Manager**

iBiquity's field test Program Manager is responsible for test program tracking and scheduling, as well as, management of in-field measurements. The Program Manager reports to the Engineering Manager. The Program Manager is Russ Mundschenk.

#### **1.15 Auditing Engineers (Auditors)**

The Auditing Engineers are contracted through ATTC to participate and monitor the field test program. Administratively, the Auditors report to Charles Einolf, Deputy Executive Director, ATTC. In technical matters, the Auditors operate as consultants to the Engineering and Program Managers. The Auditing Engineers are Dennis Wallace and William Meintel.

### **1.16 Supervising Engineers**

All field test teams must include at least one iBiquity Supervising Engineer to oversee and execute testing. Supervising Engineers are familiar with both broadcast and receiver aspects of digital and analog systems. Supervising Engineers report to the Engineering Manager. Pat Malley and Tom Walker are the Supervising Engineers.

### **1.17 Test Engineers**

iBiquity Test Engineers report to the Supervising Engineers. Test Engineers execute technical procedures under the guidance of the Supervising Engineers and Auditors. Test Engineers specialize in testing, configuration and maintenance of the digital receivers and/or the mobile test platform. Test Engineers are Charles Belsches, Kenneth Brockel, Keith Ege and David Twyman.

## **Procedural Deviations**

As occurs in nearly every test program, the need for deviation from a prescribed procedure will arise. Any prospective deviations from procedure shall be reported to the field test Engineering Manager for consideration. In the absence of the Engineering Manager, prospective deviations shall be reported to the Program Manager. With the advice of the Auditing Engineers, the Engineering and/or Program Manager shall decide whether a prospective procedural deviation may be authorized in the field by iBiquity field test management, or must be referred to the NRSC DAB Subcommittee's Steering Committee for consideration. In the latter case, the Engineering Manager or iBiquity senior management team will present the prospective deviation before the Steering Committee.

For all changes and prospective changes to procedure, the test team shall document the deviation in full detail plus the decision process leading to the authorization of the procedural change.

## **10. Attachments**

**Attachment A: Drive Test Platform Set-up & Operation Notes**

*The test team should add to this section any notes that will prove helpful in continued and future testing.*

<b>Entry Date</b>	<b>Van I.D.</b>	<b>Key Words</b>	<b>Description</b>	<b>Resolution</b>
15 March, 2001	All	Audio, patch panel, level variations, hum	The half-normalled switching in the AP audio patch panel is unreliable.	Hard patch all patch panel connections using balanced, ¼ inch TRS patch cables.
15 March, 2001	All	EMI, EMC, power supply, inverter, UPS	UPS may cause FM band conducted/radiated interference	Remove APC UPS from power supply distribution. Causes EMI.
1 June, 2001	All	SCA, , ground loop, isolation	Connection of the SCA receivers to a van's antenna network, AC mains and the audio recording system may result in audio ground loops and/or shorting of some receivers' internal power supplies.	All SCA receivers should be connected to the antenna distribution network through a 1:1 RF isolation transformer.

Attachment B: TakeATest (TAT1v1) Control Screen Image

**iBIQUITY Digital**  
File Settings Option Help

**File Save Options**

Tape Name: fest1.txt  
 Path: d:\  
 File Name: fest1.txt  
 Create New File With This Name  
 Append To This File

SMPTE Time: - - - last received  
 h m s

**New File Will Be Created**

Stopped

Lwr IBOC: 102.6 MHz  
 HOST: 102.7 MHz  
 Upr IBOC: 102.8 MHz

Test #: 1 2  
 <BACK [ ] MORE>

CF (MHz): 102.7 100  
 Span (kHz): 500 2000  
 Ampl. (dBm): -40  
 RBW (kHz): 10 20  
 VBW (kHz): 10 20  
 Every: 4 s 8 s  
 Time(s): 4 4  
 Average: OFF OFF

**SETTINGS**

Anal. Add.: 18 SMPTE Comm. Port: Comm 2  
 Cam. Add.: 135.22.225.12 type: 2401 GPS Comm. Port: Comm 1  
 RADIO Comm. Port: Not Used

**iBIQUITY DIGITAL**  
© 2000 J.J.

Camera: Can't Get Data From Spectrum  
 Queue: Can't Retrieve Spectrum

GPS: RPV68798+4065172-07457171000000001  
 Radio Stat. [Red Bar]

Start Recording (Ctrl-F1)

- Ovepass - F2
- Bridge - F3
- High Voltage Line - F4
- Tall Buildings - F5
- Stop Light Fade - F6
- Entering To City - F7
- Leaving City - F8
- Suburban Area - F9
- Forest - F10
- Village - Ctrl-F2
- Up Hill - Ctrl-F3
- Down Hill - Ctrl-F4
- Multipath - Ctrl-F5



**Attachment C: TakeATest Usage Notes**

*The test team should add to this section any notes that will prove helpful in continued and future testing.*

<b>Entry Date</b>	<b>Version of TakeATest</b>	<b>Topic</b>	<b>Description</b>	<b>Resolution</b>
16 March, 2001	TAT1v01	Reference Level Setting during Record	If two “-“ (“minus sign”) are entered with the reference level, the analyzer will not operate properly.	Do not enter more than one “-“ before the numerical value of the Reference Level
16 March, 2001	TAT1v01	Reference Level Setting during Record	Entering a new spectrum analyzer reference level during measurements may cause loss of camera network link.	If the camera network link is lost, left-click the mouse over the camera view frame to recover.
16 March, 2001	TAT1v01	Spectrum Analyzer Input Attenuation	If manually set to a low value, e.g., 0 dB, the analyzer’s reference level will not be settable over its full range.	Always set the spectrum analyzer input attenuation to “auto” mode before starting and using TAT1v01 or earlier.
16 March, 2001	TAT1v01	Antenna Network Gain Setting	Antenna network has changed since original van configuration	Nominal antenna network gain is now 5 dB (S/A path gain relative to receiver path gains)
16 March, 2001	TAT2v2	New Release	Version 2.2 includes auto reference level adjustment, set to auto mode for spectrum analyzer input attenuation, station database, distance-to-station display	
1 April, 2001	TAT2v2	Auto Reference Level Feature	Auto Reference level feature may fail to stabilize in certain signal conditions, notably at very low signal levels where operation is near analyzer noise floor. This may also occur in the presence of strong	Manually adjust spectrum analyzer reference during tests. Since data recording is suspended while test set up window is open, operator should make reference level adjustments as quickly as possible and close test set

III

				signals if input attenuation is set to manual mode.	up window immediately to resume data recording.

**Attachment D: Antenna Distribution Networks**

Figures D1, D2, D3 and D4 are the block diagrams of the three topologies of antenna distribution network used on the mobile test platform during FM IBOC tests.

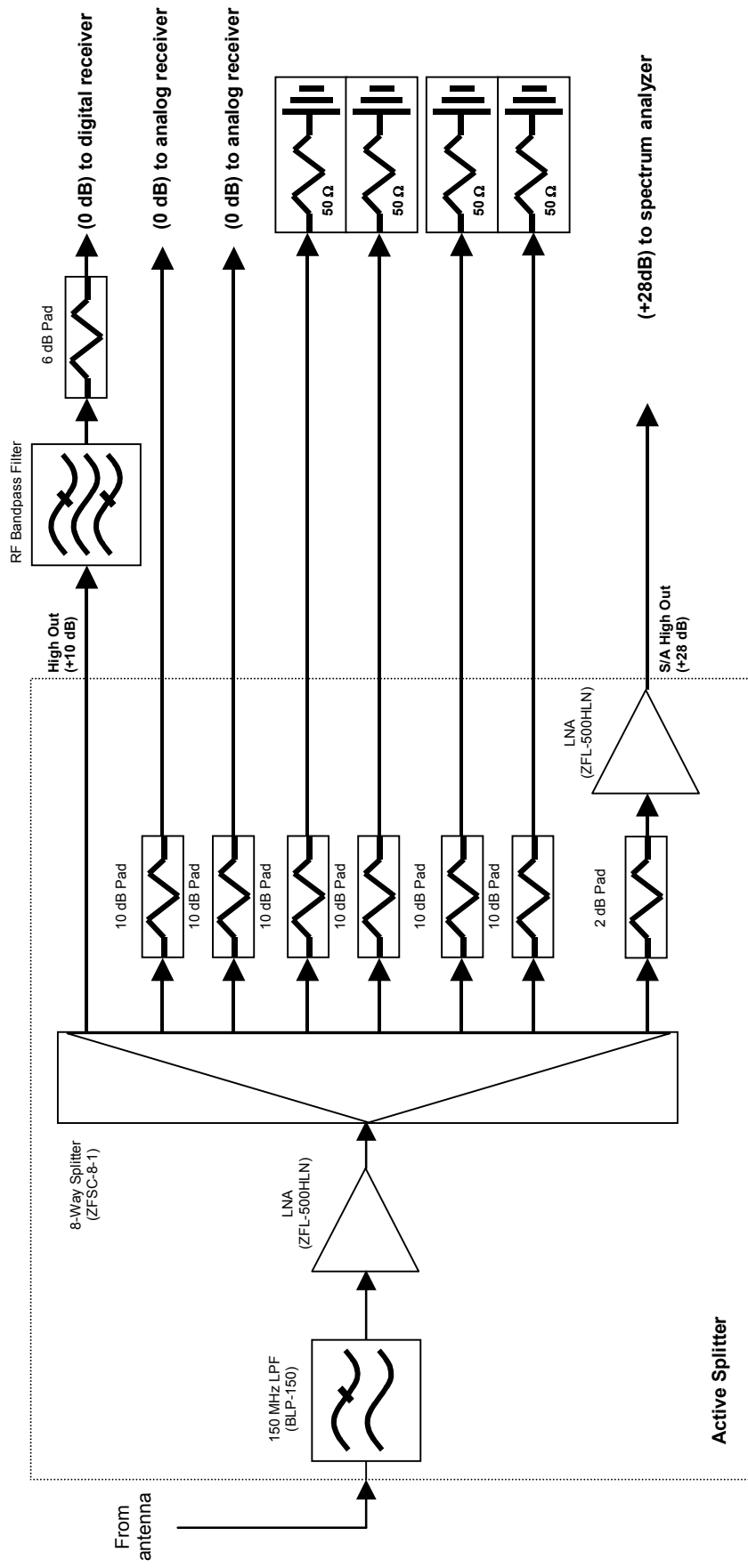

**Figure D1: Active Antenna Distribution Network Type AAN1**

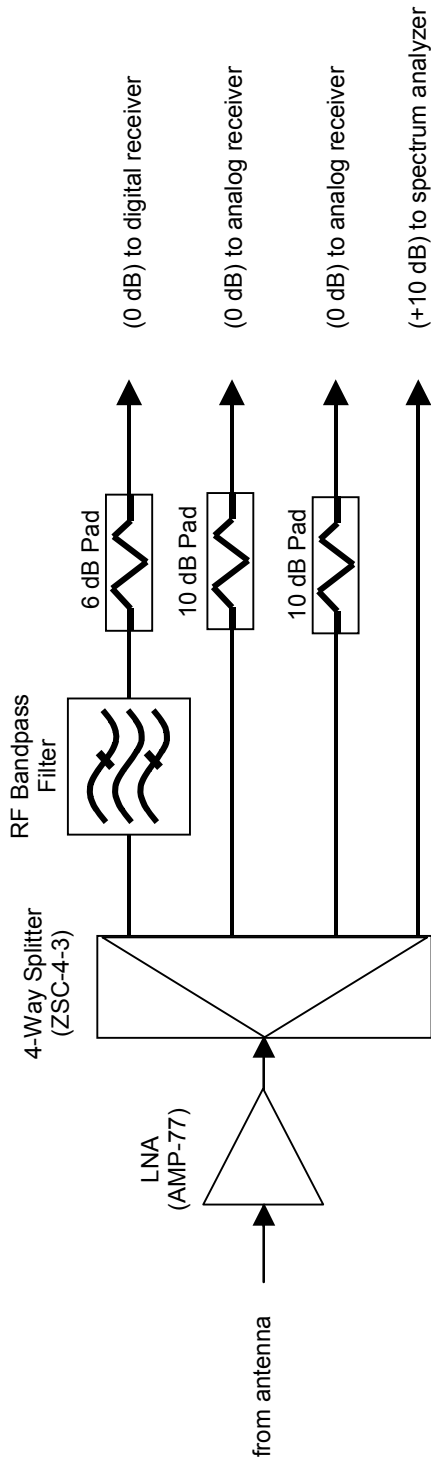
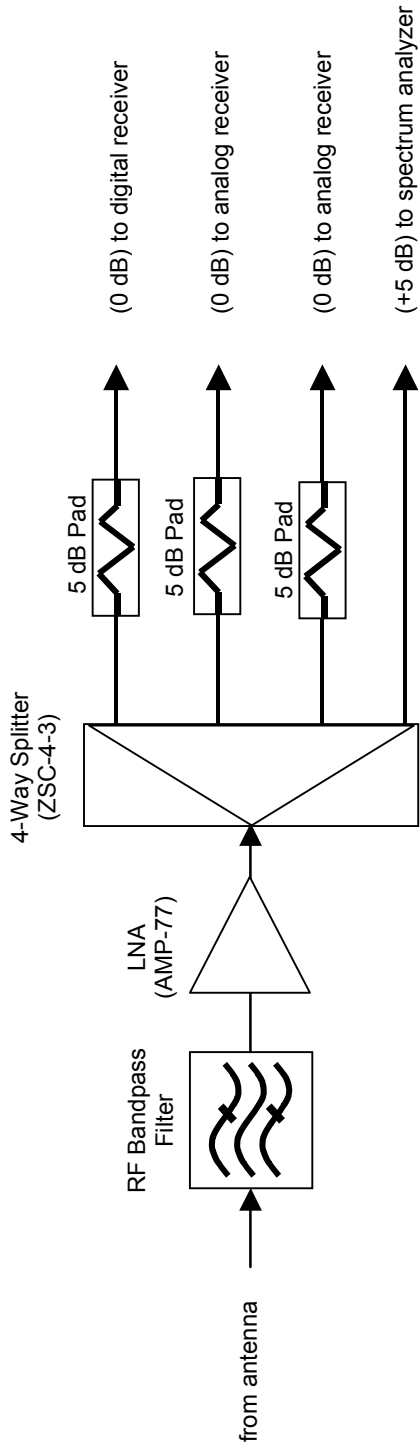
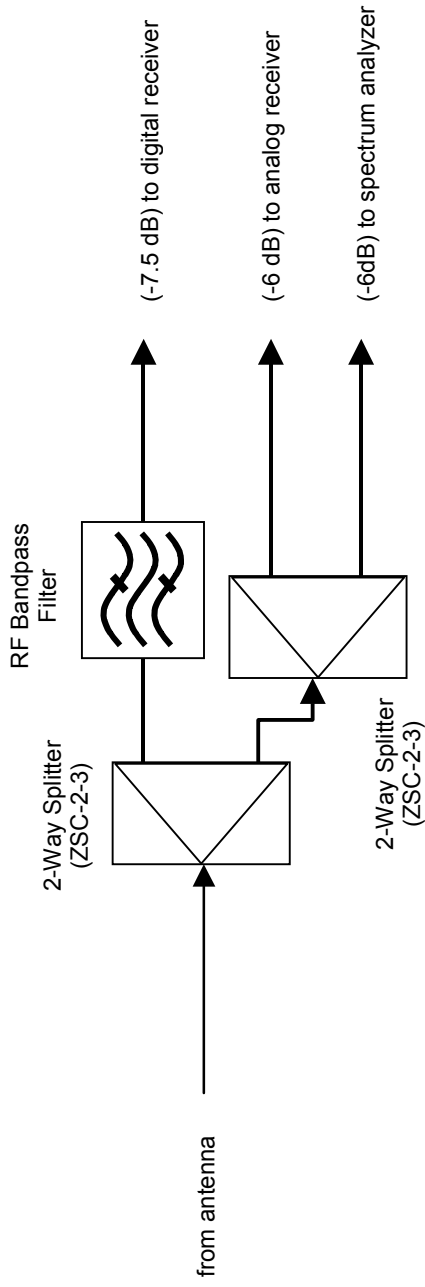

Figure D2: Active Antenna Distribution Network Type AAN2



**Figure D3: Active Antenna Distribution Network Type AAN3**



**Figure D4: Passive Antenna Distribution Network Type PAN1**

### Attachment D: EMI Remediation Notes

While there are many reasons and many solutions to eliminating EMI, the choices of remediation in the field are usually few. These include

- removal and/or replacement of the offender with a better behaved equivalent
- addition of ferrite EMI suppression devices on interface and power cables
- better shielding and grounding of device cases
- insertion of in-line EMI suppression filters on interface and power cables
- changes in placement of equipment
- changes to equipment operational and/or interface modes that will shut-down or alter internal clock or oscillator generation.

The order in which the above approaches are listed represents the more likely and effective solutions. It is often very helpful to have an experienced RF engineer on hand to assist in EMI reduction procedures.

Three more important points on this topic:

- Every test segment will require dedicated EMI testing, as an interferer will not affect every part of the FM band equally. It is not sufficient to check another, nearby FM channel for interference and assume the same situation will exist on the test segment's desired channel.
- Do not overlook the test receivers as possible sources of interference.
- Monitoring for interference in a receiver's IF signal path is the easiest and most sensitive way to observe EMI. However, detection of interference at IF is not a positive indication of EMI, as other interference mechanisms such as intermodulation and front-end spurious responses may produce similar effects.

**Not all EMI problems can be solved easily. Some solutions may require creative or radical changes to the test configuration. Be prepared to face this situation. What work for one test segment may not work for another. Again, having an experienced RF engineer on hand to help evaluate and solve EMI issues may be critical to success.**

Attachment E: Station Characterization Spreadsheet

Analog + Digital Total Power Measurement														
Spectrum Analyzer Parameters														
Msm1#	Amplitude	Units	Freq.	Units	Span	Units	RBW	Units	Video Avg	# Video Avgs	VBW	Units	Mkt Freq	Noise Market
1	dBm	dBm	93.5 MHz	500 kHz	500 kHz	300 kHz	1 MHz	1 MHz	ON	50	50	1 kHz	93.500 MHz	OFF
2	dBm	dBm	93.5 MHz	500 kHz	500 kHz	300 kHz	1 MHz	1 MHz	ON	50	50	1 kHz	93.500 MHz	OFF
3	dBm	dBm	93.5 MHz	500 kHz	500 kHz	300 kHz	1 MHz	1 MHz	ON	50	50	1 kHz	93.500 MHz	OFF
4	dBm	dBm	93.5 MHz	500 kHz	500 kHz	300 kHz	1 MHz	1 MHz	ON	50	50	1 kHz	93.500 MHz	OFF
5	dBm	dBm	93.5 MHz	500 kHz	500 kHz	300 kHz	1 MHz	1 MHz	ON	50	50	1 kHz	93.500 MHz	OFF
6	dBm	dBm	93.5 MHz	500 kHz	500 kHz	300 kHz	1 MHz	1 MHz	ON	50	50	1 kHz	93.500 MHz	OFF
7	dBm	dBm	93.5 MHz	500 kHz	500 kHz	300 kHz	1 MHz	1 MHz	ON	50	50	1 kHz	93.500 MHz	OFF
8	dBm	dBm	93.5 MHz	500 kHz	500 kHz	300 kHz	1 MHz	1 MHz	ON	50	50	1 kHz	93.500 MHz	OFF
9	dBm	dBm	93.5 MHz	500 kHz	500 kHz	300 kHz	1 MHz	1 MHz	ON	50	50	1 kHz	93.500 MHz	OFF
10	dBm	dBm	93.5 MHz	500 kHz	500 kHz	300 kHz	1 MHz	1 MHz	ON	50	50	1 kHz	93.500 MHz	OFF
11	dBm	dBm	93.5 MHz	500 kHz	500 kHz	300 kHz	1 MHz	1 MHz	ON	50	50	1 kHz	93.500 MHz	OFF
12	dBm	dBm	93.5 MHz	500 kHz	500 kHz	300 kHz	1 MHz	1 MHz	ON	50	50	1 kHz	93.500 MHz	OFF
13	dBm	dBm	93.5 MHz	500 kHz	500 kHz	300 kHz	1 MHz	1 MHz	ON	50	50	1 kHz	93.500 MHz	OFF
14	dBm	dBm	93.5 MHz	500 kHz	500 kHz	300 kHz	1 MHz	1 MHz	ON	50	50	1 kHz	93.500 MHz	OFF
<b>Transmitter Measurements</b>														
Analog + DAB Power (Total) = 10 <sup>Δ</sup> (Amplitude dBm/10)														
Analog Power Only mW - Measured = 10 <sup>Δ</sup> (Amplitude dBm/10)														
DAB Power mW (Lower) = 10 <sup>Δ</sup> (Amplitude dBm/10) X 70.000														
DAB Power mW (Upper) = 10 <sup>Δ</sup> (Amplitude dBm/10) X 70.000														
DAB Power mW (Total) = Analog + DAB Power (Lower) + DAB Power (Upper)														
Analog Only mW (Total) - Calculated = 10 Log [(DAB Power mW (Total)) / (Analog Only mW (Total))]														
DAB (Total) / Analog Ratio = 10 Log [(DAB Power mW (Total)) / (Analog Only mW (Total))]														
<b>Field Measurements</b>														
Analog + DAB Power (Total) = 10 <sup>Δ</sup> (Amplitude dBm/10)														
DAB Power mW (Lower) = 10 <sup>Δ</sup> (Amplitude dBm/10) X 70.000														
DAB Power mW (Upper) = 10 <sup>Δ</sup> (Amplitude dBm/10) X 70.000														
DAB Power mW (Total) = Analog + DAB Power (Lower) + DAB Power (Upper)														
Analog Only mW (Total) - Calculated = 10 Log [(DAB Power mW (Total)) / (Analog Only mW (Total))]														
DAB (Total) / Analog Ratio = 10 Log [(DAB Power mW (Total)) / (Analog Only mW (Total))]														
Analog + DAB Power (Total) = 10 <sup>Δ</sup> (Amplitude dBm/10)														
DAB Power mW (Lower) = 10 <sup>Δ</sup> (Amplitude dBm/10) X 70.000														
DAB Power mW (Upper) = 10 <sup>Δ</sup> (Amplitude dBm/10) X 70.000														
DAB Power mW (Total) = Analog + DAB Power (Lower) + DAB Power (Upper)														
Analog Only mW (Total) - Calculated = 10 Log [(DAB Power mW (Total)) / (Analog Only mW (Total))]														
DAB (Total) / Analog Ratio = 10 Log [(DAB Power mW (Total)) / (Analog Only mW (Total))]														

Date: 03/12/01  
Time: 10:00 - 1300

At 300 kHz RBW Transmitter Sample

At 1 MHz RBW Transmitter Sample

At 300 kHz RBW

At 1 MHz RBW Field Sample

## Attachment F: Field Test Radio Assignments

Ref.	Radio	iBiquity Identification	Model Number	Serial Number	Characterization?	Van Assignment	Audio Channel Assignments
1	Digital	Dev13	-	-	Yes – iBiquity Lab	Van 2 – west coast	Left – 7 Right – 8
2	Delphi-Delco	IBQ01	PN 09394139	89DDSTM103490263	Yes – R. McCutcheon	Van 2 – west coast	Left – 1 Right - 2
3	Pioneer	IBQ EIA #17	KEH-1900	-	Yes – R. McCutcheon	Van 2 – west coast	Left – 3 Right - 4
4	Digital	Dev35	-	-	Yes – iBiquity Lab	Van 1 – east coast	Left – 1 Right - 2
5	Delphi-Delco	IBQ03	PN 09394139	-	Yes – R. McCutcheon	Van 1 – east coast	Left – 3 Right - 4
6	Pioneer	IBQ EIA # 19	KEH-1900	-	Yes – R. McCutcheon	Van 1 – east coast	Left – 5 Right - 6
7	Technics	IBQ08	SA-EX110	GXOEA49056	Yes – R. McCutcheon	Van 1 – east coast	Left – 1 <sup>note 8</sup> Right - 2
8	Sony	IBQ011	CFD-S22	SO1-0616690-E	Yes – R. McCutcheon	Van 1 – east coast	Left – 7 Right - 8

---

<sup>8</sup> For compatibility testing only, the Technics Receiver takes the place of the digital receiver for audio channel assignment.