



HD Radio™ Air Interface Design Description Layer 2 Channel Multiplex

Rev. J

December 14, 2016

TRADEMARKS

HD Radio™ and the HD, HD Radio, and “Arc” logos are proprietary trademarks of iBiquity Digital Corporation.

“iBiquity”, “iBiquity Digital”, and the iBiquity Digital logo are also proprietary trademarks of iBiquity.

All other trademarks, whether claimed or registered, are the exclusive property of their respective owners.

iBiquity Digital Corporation

6711 Columbia Gateway Drive, Suite 500

Columbia, MD 21046

Voice: 443-539-4290

Fax: 443-539-4291

E-mail address:

info@ibiquity.com

Table of Contents

Contents

1	SCOPE	1
1.1	System Overview	1
1.2	Document Overview	1
2	REFERENCE DOCUMENTS	2
3	ABBREVIATIONS AND CONVENTIONS	3
3.1	Introduction	3
3.2	Abbreviations and Acronyms	3
3.3	Presentation Conventions	4
3.4	Mathematical Symbols	4
3.4.1	Variable Naming Conventions	4
3.4.2	Arithmetic Operators	5
4	LAYER 2 TRANSPORT – DESCRIPTION	6
5	LAYER 2 PDU GENERATION.....	8
5.1	Layer 2 PDU Structure and Content	8
5.1.1	MPS and SPS Multiplexing	10
5.2	Layer 2 PCI.....	14
5.3	Order of Content	16
6	LAYER 2 PROCESSING	18
6.1	Transmit Processing Description	18

List of Figures

Figure 4-1: Layer 2 – Interface Diagram	7
Figure 5-1: L2 PDU Structure Based on Content	9
Figure 5-2: Generic L2 Transfer Frame	14
Figure 5-3: Order of Content	16
Figure 5-4: Layer 2 Order of Multiple Instances of Audio-Oriented Content	16
Figure 5-5: Layer 2 Order of Data Content Control Information	17

List of Tables

Table 5-1: Mapping of Services/Programs to Logical Channels vs FM Service Mode – Example Configurations	10
Table 5-2: Mapping of Services/Programs to Logical Channels vs AM Service Mode – Example Configurations ...	13
Table 5-3: Generic Header Sequence Indications	14
Table 5-4: Header Spread Parameters	15

1 Scope

1.1 System Overview

The iBiquity Digital Corporation HD Radio™ system is designed to permit a smooth evolution from current analog amplitude modulation (AM) and frequency modulation (FM) radio to a fully digital in-band on-channel (IBOC) system. This system delivers digital audio and data services to mobile, portable, and fixed receivers from terrestrial transmitters in the existing medium frequency (MF) and very high frequency (VHF) radio bands. Broadcasters may continue to transmit analog AM and FM simultaneously with the new, higher-quality, and more robust digital signals, allowing themselves and their listeners to convert from analog to digital radio while maintaining their current frequency allocations.

1.2 Document Overview

This document defines Layer 2, the channel multiplexer. Specific hardware and software implementation is not described. See References [1], [2], [7], [9], [4], [5], and [6] for more details.

2 Reference Documents

STATEMENT

Each referenced document that is mentioned in this document shall be listed in the following iBiquity document:

- Reference Documents for the NRSC In-Band/On-Channel Digital Radio Broadcasting Standard
Document Number: SY_REF_2690s

3 Abbreviations and Conventions

3.1 Introduction

Section 3 provides the following:

- Abbreviations and Acronyms
- Presentation Conventions
- Mathematical Symbols

3.2 Abbreviations and Acronyms

AAS	Advanced Application Services
AAT	AAS Data Transport
AM	Amplitude Modulation
CA	Conditional Access
CW	Control Word
DDL	Data Delimiter
FM	Frequency Modulation
HD RLS	HD Radio Link Subsystem
IBOC	In-Band On-Channel
ISO	International Organization for Standardization
L1	Layer 1
L2	Layer 2
MF	Medium Frequency
MPS	Main Program Service
MPSA	Main Program Service Audio
MPSD	Main Program Service Data
MSB	Most Significant Bit
PCI	Protocol Control Information
PDU	Protocol Data Unit
PIDS	Primary IBOC Data Service Logical Channel
PSD	Program Service Data
SIDS	Secondary IBOC Data Service Logical Channel
SIS	Station Information Service
SPS	Supplemental Program Service
SPSA	Supplemental Program Service Audio
SPSD	Supplemental Program Service Data
VHF	Very High Frequency

3.3 Presentation Conventions

Unless otherwise noted, the following conventions apply to this document:

- All vectors are indexed starting with 0.
- The element of a vector with the lowest index is considered to be first.
- In drawings and tables, the leftmost bit is considered to occur first in time.
- Bit 0 of a byte or word is considered the least significant bit.
- When presenting the dimensions of a matrix, the number of rows is given first (e.g., an n x m matrix has n rows and m columns).
- In timing diagrams, earliest time is on the left.
- Binary numbers are presented with the most significant bit having the highest index.
- In representations of binary numbers, the least significant bit is on the right.

3.4 Mathematical Symbols

3.4.1 Variable Naming Conventions

The variable naming conventions defined below are used throughout this document.

Category	Definition	Examples
Lower and upper case letters	Indicates scalar quantities	i, j, J, g ₁₁
Underlined lower and upper case letters	Indicates vectors	<u>u</u> , <u>V</u>
Double underlined lower and upper case letters	Indicates two-dimensional matrices	<u><u>u</u></u> , <u><u>V</u></u>
[i]	Indicates the i th element of a vector, where i is a non-negative integer	<u>u</u> [0], <u>V</u> [1]
[]	Indicates the component of a vector	<u>v</u> = [0, 10, 6, 4]
[i] [j]	Indicates the element of a two-dimensional matrix in the i th row and j th column, where i and j are non-negative integers	<u><u>u</u></u> [i][j], <u><u>V</u></u> [i][j]
[]	Indicates the components of a matrix	<u><u>m</u></u> = $\begin{bmatrix} 0 & 3 & 1 \\ 2 & 7 & 5 \end{bmatrix}$
n ... m	Indicates all the integers from n to m, inclusive	3 ... 6 = 3, 4, 5, 6
n:m	Indicates bit positions n through m of a binary sequence or vector	Given a binary vector i = [0, 1, 1, 0, 1, 1, 0, 0], i _{2:5} = [1, 0, 1, 1]

3.4.2 Arithmetic Operators

The arithmetic operators defined below are used throughout this document.

Category	Definition	Examples
·	Indicates a multiplication operation	$3 \cdot 4 = 12$
INT()	Indicates the integer portion of a real number	$\text{INT}(5/3) = 1$ $\text{INT}(-1.8) = -1$
a MOD b	Indicates a modulo operation	$33 \text{ MOD } 16 = 1$
\oplus	Indicates modulo-2 binary addition	$1 \oplus 1 = 0$
	Indicates the concatenation of two vectors	$\underline{A} = [\underline{B} \mid \underline{C}]$ The resulting vector \underline{A} consists of the elements of \underline{B} followed by the elements of \underline{C} .
j	Indicates the square-root of -1	$j = \sqrt{-1}$
Re()	Indicates the real component of a complex quantity	If $x = (3 + j4)$, $\text{Re}(x) = 3$
Im()	Indicates the imaginary component of a complex quantity	If $x = (3 + j4)$, $\text{Im}(x) = 4$
\log_{10}	Indicates the base-10 logarithm	$\log_{10}(100) = 2$
*	Indicates complex conjugate	If $x = (3 + j4)$, $x^* = (3 - j4)$
0x	Indicates a hexadecimal value	$0x10 = 16$

4 Layer 2 Transport – Description

The primary function of Layer 2 is to receive audio and data from various higher layers within the HD Radio system, multiplex this information into Layer 2 Protocol Data Units (PDU) and route these PDUs to the appropriate Layer 1 logical channel. The data received from the higher layers is also in the form of PDUs but from the individual transport layers providing the service. Layer 2 enables the HD Radio system to support four transport services as described below and shown in Figure 4-1:

1. Main Program Service (MPS) which includes Main Program Service Audio (MPSA) and may also include Main Program Service Data (MPSD). MPS PDUs are generated by the Audio Transport and encapsulate both MPSA and MPSD information.
2. Supplemental Program Service (SPS) provides the broadcaster the option of multiplexing additional programs with the MPS. The SPS includes Supplemental Program Service Audio (SPSA) and may also include Supplemental Program Service Data (SPSD). SPS PDUs are generated by the same Audio Transport as the MPS PDUs.
3. Advanced Application Services (AAS) provides the broadcaster the option of multiplexing additional types of content, other than SPS, along with the MPS. It provides the packet transport mechanism for these services. It performs the framing and the encapsulation of the data packets. There are two types of methods for multiplexing AAS data into a Layer 2 PDU: fixed and opportunistic. Fixed data is granted a fixed bandwidth allocation by purposely scaling back the bandwidth allocation of the MPS, whereas opportunistic makes use of any unused bandwidth due to variability of both the MPS and SPS Audio.
4. Station Information Service (SIS) is a specialized transport/data link for transmitting SIS data on the Primary IBOC Data Service (PIDS) and the Secondary IBOC Data Service (SIDS) Layer 1 logical channels. For such Layer 1 logical channel, Layer 2 does not perform a multiplexing function, but rather just passes the SIS (PDUs) directly into the Layer 1 PIDS or SIDS logical channel without additional overhead in the form of headers. The SIS PDU is the only PDU contained within the PIDS or SIDS Layer 1 logical channel.

The HD Radio system supports various configurations with respect to Layer 1. Based on the Layer 1 service mode, the system provides multiple Layer 1 logical channels. The number of active Layer 1 logical channels and the characteristics defining them vary for each service mode. The defining characteristics of each Layer 1 logical channel are:

- Transfer Frame Size
- Transfer Frame Rate
- Robustness
- Latency

Details of the logical channels used for each L1 service mode are described in References [1] and [2].

With respect to the exchange between Layer 2 and Layer 1, Layer 2 is subjected to the Layer 1 configuration and timing. The configuration is governed by the control information received from the Configuration Administrator. The total Layer 1 frame size consists of the total Layer 2 PDU size and the L2 Protocol Control Information (PCI) overhead. Layer 2 allows the MPS/SPS and AAS Transports to be active within any active Layer 1 logical channel, with the exception of PIDS and SIDS.

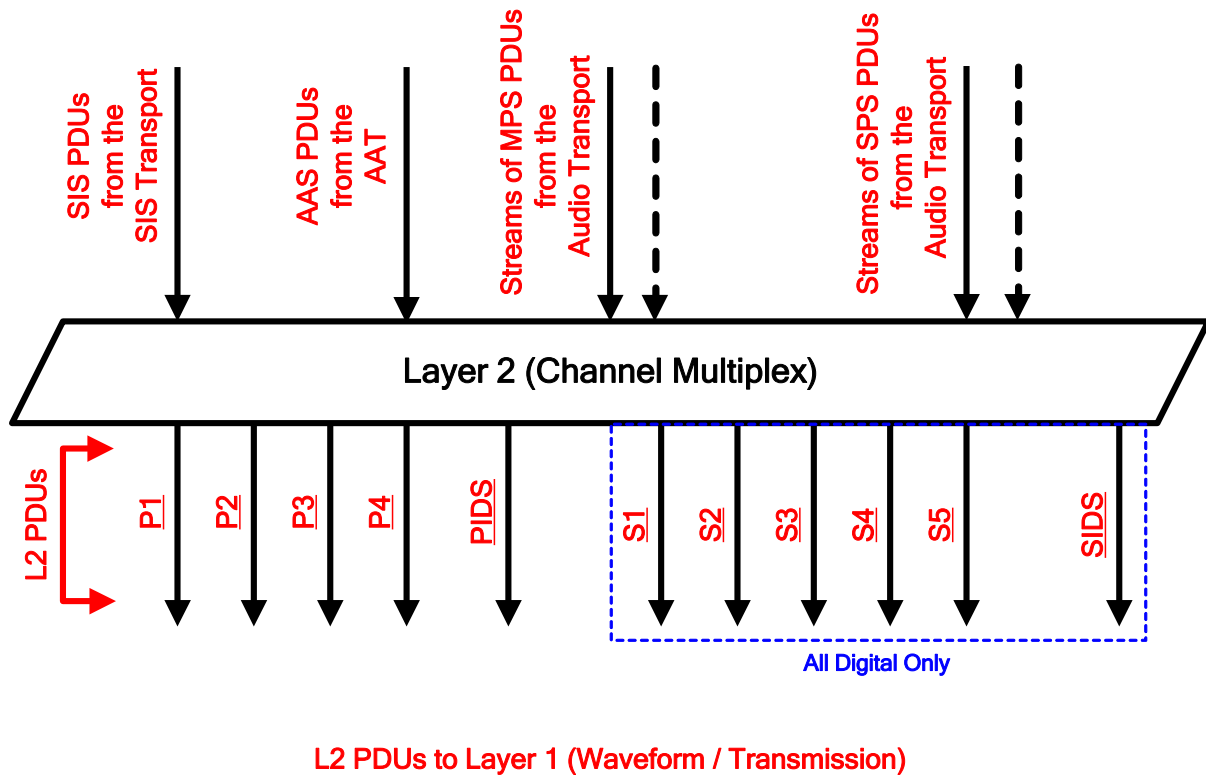

Figure 4-1: Layer 2 – Interface Diagram

In addition to the Layer 2 PDUs, status information is also passed between Layer 1 and Layer 2. The status information passed from Layer 1 to Layer 2 consists of *Absolute L1 Frame Number* (ALFN) and *L1 Block Count* (BC).

5 Layer 2 PDU Generation

This section describes the Layer 2 Protocol Control Information (PCI) included as part of the Layer 2 PDU for every Layer 1 logical channel in the HD Radio system. It also describes the details of how the various service PDUs are multiplexed into a Layer 2 PDU.

5.1 Layer 2 PDU Structure and Content

SPS and AAS are optional. But when available, the structure of a Layer 2 PDU can contain five different possible combinations of audio and data:

- a. The payload is audio oriented (MPS/SPS).
- b. A mixed content payload, containing MPS/SPS, opportunistic data.
- c. A mixed content payload, containing MPS/SPS, fixed data.
- d. A mixed content payload, containing MPS/SPS, opportunistic data and fixed data.
- e. The payload contains fixed data.

Figure 5-1 shows the structure of an L2 PDU depending on content. This does not apply to the PIDS or SIDS logical channels which exclusively carry SIS PDUs. It represents the L2 PDU structures for each logical channel carrying combinations of audio and data.

Opportunistic data is made available only when the audio (MPS/SPS) does not use its allocated bandwidth. The MPS/SPS PDU lengths are based on the maximum bit rate for a particular audio codec mode. The unused portions of the bandwidth are then aggregated and used to include opportunistic data. It can originate in both the MPS and SPS; however, it is combined in the AAS Data Transport using the HD RLS before sending it to Layer 2 as part of the AAS PDUs.

Thus, opportunistic data is PDU-specific and cannot be guaranteed at any particular rate or instance in time, making it a service of lesser quality. Also, fixed data and opportunistic data can occur independently across logical channels.

When the L2 PDU contains an AAS Data PDU containing fixed data, an extended header is deployed within the HD RLS. The format and structure of both fixed and opportunistic data processed by the HD RLS is described in [5]. The mixed content PDU requires additional indications. A delimiter is provided by HD RLS, indicating the payload parts associated with each type of service. To allow opportunistic data to be identified in the Layer 2 PDU, a 5-byte data delimiter (DDL) field is used to identify the start of the opportunistic data in the PDU. Refer to [5] for details.

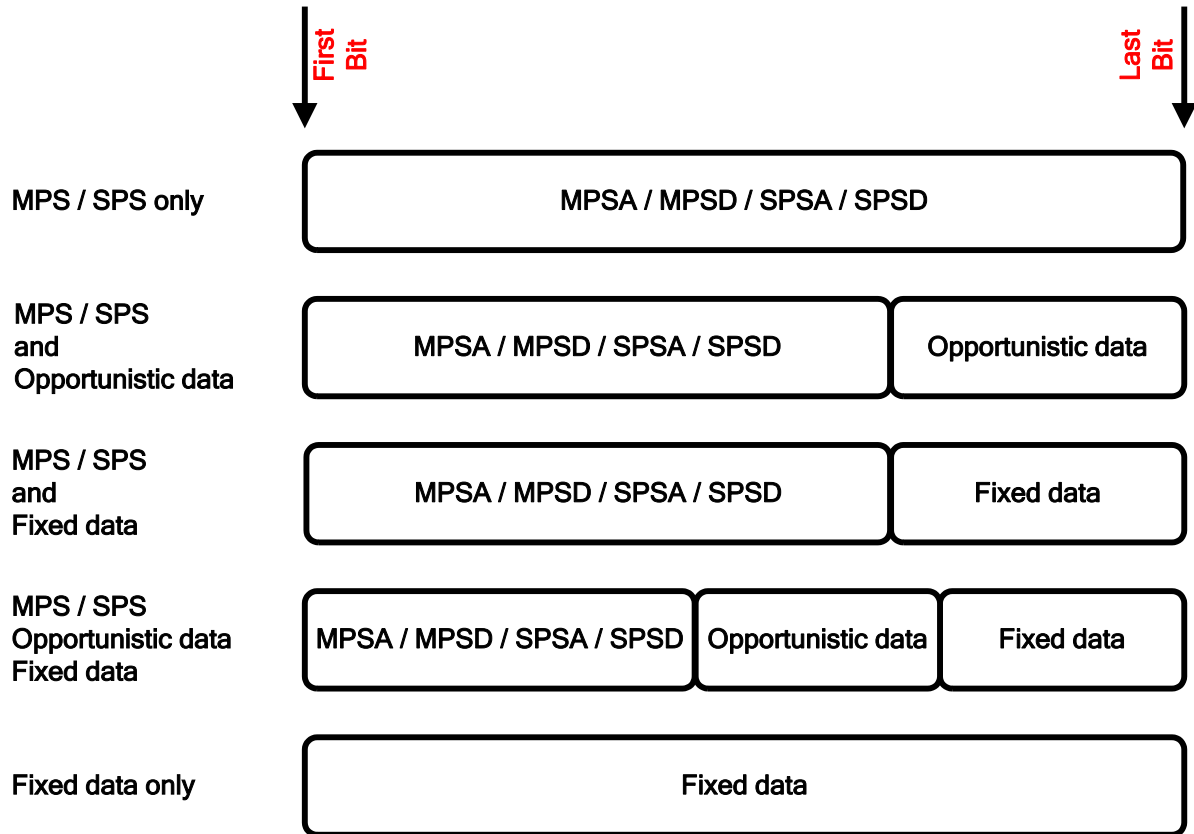

Figure 5-1: L2 PDU Structure Based on Content

5.1.1 MPS and SPS Multiplexing

MPS and SPS employ an identical transport mechanism; thus, care must be taken when multiplexing these PDUs into a Layer 2 PDU so that the receiver can correctly process the PDUs as well as provide the listener with an accurate description of the available programs. This requires further attention due to the fact that both MPSA and SPSA can contain core and enhanced streams that are transported on different Layer 1 logical channels. This subsection describes the restrictions and configurations when multiplexing and processing MPS and SPS programs.

Table 5-1 shows various configurations for mapping services/programs to logical channels for each FM service mode. The desired broadcast configuration is chosen based on the quality of service for the particular application, in combination with allocation requirements as described in this document. Table 5-1 is a set of sample configurations based on a maximum of three SPSs in addition to the MPS; however, additional configurations can be added in the future to include up to seven SPSs.

Layer 2 PDU construction adheres to the following guidelines:

- The Main Program Service is always designated as Program Number “0”.
- SPS1 and SPS2 can reference Program Numbers 1 through 7. Refer to [4] for a detailed description on Program Number and program indications.
- AAS Data consists of fixed data and the opportunistic data, if available.
- Programs 1 through 7 can be added or removed at any time, but Program 0 is constantly present.
- The core stream is added or removed first in a multi-stream program.
- The Main Program must be first in the order in the physical L2 PDU.
- Free-access Supplemental Programs can be placed in any order in the PDU.
- Conditionally-accessed Supplemental Programs shall be placed last in the PDU. Refer to Subsection 5.3 for details.

Table 5-1: Mapping of Services/Programs to Logical Channels vs FM Service Mode – Example Configurations

Service Mode	MPS		SPS-1		SPS-2		SPS-3		SIS Data	AAS Data (Fixed Data and Opportunistic Data)
	Core Channel	Enhanced Channel	Core Channel	Enhanced Channel	Core Channel	Enhanced Channel	Core Channel	Enhanced Channel		
MP1	P1	—	—	—	—	—	—	—	PIDS	P1
	P1	—	P1	—	—	—	—	—	PIDS	P1
	P1	—	P1	—	P1	—	—	—	PIDS	P1
MP2	P1	—	P3	—	—	—	—	—	PIDS	P1/P3
	P1	—	P1	—	P3	—	—	—	PIDS	P1/P3
MP3	P1	—	P3	—	—	—	—	—	PIDS	P1/P3
	P1	—	P1	—	P3	—	—	—	PIDS	P1/P3
	P1	—	P1	P3	—	—	—	—	PIDS	P1/P3
	P1	—	P3	P1	—	—	—	—	PIDS	P1/P3
	P1	—	P1	—	P1	P3	—	—	PIDS	P1/P3
	P1	—	P1	—	P3	P1	—	—	PIDS	P1/P3

Service Mode	MPS		SPS-1		SPS-2		SPS-3		SIS Data	AAS Data (Fixed Data and Opportunistic Data)
	Core Channel	Enhanced Channel	Core Channel	Enhanced Channel	Core Channel	Enhanced Channel	Core Channel	Enhanced Channel		
MP11	P1	—	P1	—	P3	P4	—	—	PIDS	P1/P3/P4
	P1	—	P1	—	P1	—	P3	P4	PIDS	P1/P3/P4
	P1	—	P1	—	P3	—	P4	—	PIDS	P1/P3/P4
MP5	P1	P2		—	—	—	—	—	PIDS	P1/P2/P3
	P1	P2	P2	—	—	—	—	—	PIDS	P1/P2/P3
	P1	P2	P2	—	P3	—	—	—	PIDS	P1/P2/P3
	P1	P2	P3	—	—	—	—	—	PIDS	P1/P2/P3
	P1	P2	P2	P3	—	—	—	—	PIDS	P1/P2/P3
	P1	P2	P3	P2	—	—	—	—	PIDS	P1/P2/P3
MP6	P1	P2	—	—	—	—	—	—	PIDS	P1/P2
	P1	P2	P2	—	—	—	—	—	PIDS	P1/P2
	P1	P2	P1	—	—	—	—	—	PIDS	P1/P2
	P1	P2	P2	—	P2	—	—	—	PIDS	P1/P2
	P1	P2	P1	P2		—	—	—	PIDS	P1/P2
	P1	P2	P1	P2	P2	—	—	—	PIDS	P1/P2

The logical channels may transport the encoded audio (MPS/SPS) on the core stream or on both the core stream and the enhanced stream. Since the core stream must be present before the enhanced stream can be added, removing the core stream effectively removes the specific program. See Reference [4] for more information on the core and enhanced bit streams and the nominal bit rates.

The main stream (core stream) is sent over the more robust logical channel. Refer to [1] for a detailed description of service modes, logical channels, and backward compatibility.

For the Main Program Service, the core stream is always provided over logical channel P1. Providing the core stream over logical channel P1 is necessary in order to ensure backward compatibility of service modes.

For all programs (MPS and SPS), a particular logical channel does not carry more than one stream (core or enhanced) of the same program. Similarly, a particular stream is not split across logical channels.

Table 5-2 shows various example configurations for mapping services/programs to logical channels for each AM service mode. The desired broadcast configuration is chosen based on the quality of service for the particular application, in combination with allocation requirements as described in this document.

The first row in Table 5-2 shows the standard MA1 configuration of core and enhanced MPS audio. Optionally, the core and enhanced audio bit rates can be scaled back to provide for AAS data on the P3 and P1 logical channels. The second row shows a different case where the MPS enhanced audio on the P3 logical channel is disabled and replaced with an SPS audio program. In this case, the SPS audio is a single core stream.

In the reduced digital bandwidth configuration (RDB=1), the secondary and tertiary subcarriers are shut off so that there is no P3 logical channel. In this case, the MPS audio is a single core stream which can optionally be scaled back in bit rate to provide for AAS data.

Similar configurations are shown for MA3. The one difference is that for MA3, sufficient capacity exists to allow for both an SPS audio program as well as AAS data simultaneously. But for MA1, simultaneous operation of AAS data and SPS audio is not defined.

Table 5-2 is a set of sample configurations.

Table 5-2: Mapping of Services/Programs to Logical Channels vs AM Service Mode – Example Configurations

Service Mode	MPS		SPS1		SIS Data	AAS Data (Fixed Data and Opportunistic Data)
	Core Channel	Enhanced Channel	Core Channel	Enhanced Channel		
MA1 (RDB=0)	P1	P3	—	—	PIDS	P1/P3
MA1 (RDB=0)	P1	—	P3	—	PIDS	—
MA1 (RDB =1)	P1	—	—	—	PIDS	P1
MA3 (RDB=0)	P1	P3		—	PIDS	P1/P3
MA3 (RDB=0)	P1	—	P3	—	PIDS	P1
MA3 (RDB=1)	P1	—	—	—	PIDS	P1

Note: RDB=1 indicates that the P3 logical channel is unavailable.

5.2 Layer 2 PCI

The Layer 2 PCI consists of one of eight cyclic permutations, CW_0 through CW_7 , of a 24-bit sequence. The PCI sequences and the corresponding indication types are described in Table 5-3. An L2 PDU is populated with the appropriate sequence based on control information obtained from the Configuration Administrator. This control information consists of:

- A flag that indicates whether or not an L2 PDU contains an MPS PDU
- The maximum size allocated for the MPS PDU
- A flag that indicates the presence of one or more SPS PDUs
- A flag that indicates whether or not an L2 PDU contains AAS Data PDU(s)
- The maximum size allocated for AAS PDU(s)

The contents of a selected CW are designated as $[h_0, h_1, h_2, \dots, h_{21}, h_{22}, h_{23}]$.

Table 5-3: Generic Header Sequence Indications

Sequence	Binary Header Sequence	Hexadecimal Equivalent	MPS/SPS	Fixed Data	Opportunistic Data
CW_0	[001110001101100011010011]	0x38D8D3	Yes	No	No
CW_1	[110011100011011000110100]	0xCE3634	Yes	No	Yes
CW_2	[111000110110001101001100]	0xE3634C	Yes	Yes	No
CW_3	[100011011000110100110011]	0x8D8D33	Yes	Yes	Yes
CW_4	[001101100011010011001110]	0x3634CE	No	Yes	No
CW_5	[100011010011001110001101]	0x8D338D	Reserved	Reserved	Reserved
CW_6	[110110001101001100111000]	0xD8D338	Reserved	Reserved	Reserved
CW_7	[011000110100110011100011]	0x634CE3	Reserved	Reserved	Reserved

To improve robustness, the PCI bits are evenly spread over most of the Layer 2 PDU, as shown in Figure 5-2. The payload is quantified in units of bytes. Any excess payload that does not constitute a byte is located at the end of the payload. The h_0 header bit is offset from the beginning of the transfer frame by N_{start} bits. Each remaining header bit is separated from the previous header bit by N_{offset} bits. N_{offset} refers to the number of bits between each pair of header bits, exclusive of the header bits themselves.

These numbers depend on the L2 PDU length (in bits), L , as shown in Table 5-4. If the L2 PDU length is an integral number of bytes, the header length is 24 bits. If the L2 PDU length is not an integral number of bytes, the header is shortened to either 23 or 22 bits as shown. If the header length is 23 bits, then h_{23} is not used. If the header length is 22 bits, then h_{22} and h_{23} are not used.

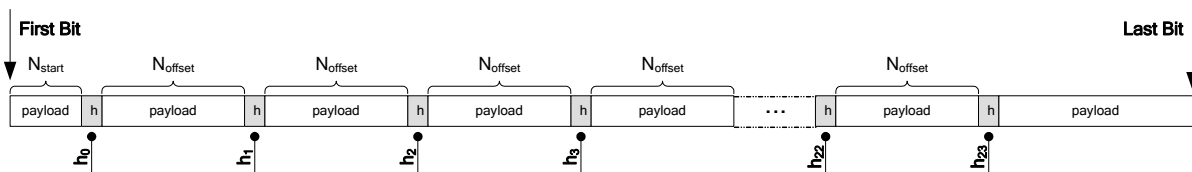

Figure 5-2: Generic L2 Transfer Frame

Table 5-4: Header Spread Parameters

L2 PDU Length, L (Bits)	(L MOD 8) =	N _{start} (Bits)	N _{offset} (Bits)	Header Length (Bits)
< 72000	0	120	$INT\left(\frac{L-120}{24}\right)-1$	24
	7	120	$INT\left(\frac{INT\left(\frac{L}{8}-14\right)}{23}\right)\cdot 8-1$	23
	1-6	120	$INT\left(\frac{INT\left(\frac{L}{8}-14\right)}{22}\right)\cdot 8-1$	22
≥ 72000	0	$L - 30000$	1247	24
	7	$8 \cdot INT\left(\frac{L}{8}\right) - 29999$	1303	23
	1 - 6	$8 \cdot INT\left(\frac{L}{8}\right) - 29999$	1359	22

5.3 Order of Content

The mix of content from different sources, each having a separate transport mechanism, requires mapping that can be tracked by the receivers under various channel conditions or under various operating scenarios. In addition, established rules for mapping content allow for future introduction of services while maintaining backward compatibility.

The structure of a Layer 2 PDU, as shown in Figure 5-1, indicates the relative placement of audio and data content. For a Layer 2 PDU, the left-most bit is referred to as bit zero (bit 0) and the right-most bit is referred to as MSB. When audio content, opportunistic data, and fixed data are present, the audio content is placed from bit 0, followed by opportunistic data, and then followed by fixed data.

A more inclusive description, as shown in Figure 5-3, emphasizes the spread of the protocol control information (PCI) across the complete Layer 2 bit aggregate. The PCI bits are independent of the payload content and are (logically) placed first, before the rest of the PDU is constructed.

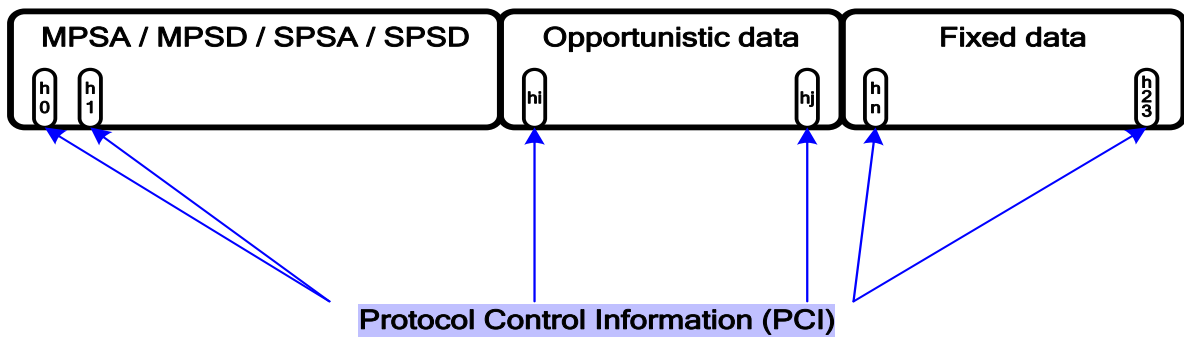

Figure 5-3: Order of Content

Audio-oriented content may include MPS transport and multiple instances of SPS transport. Figure 5-4 provides a detailed description of certain order requirements within the audio content in Layer 2.

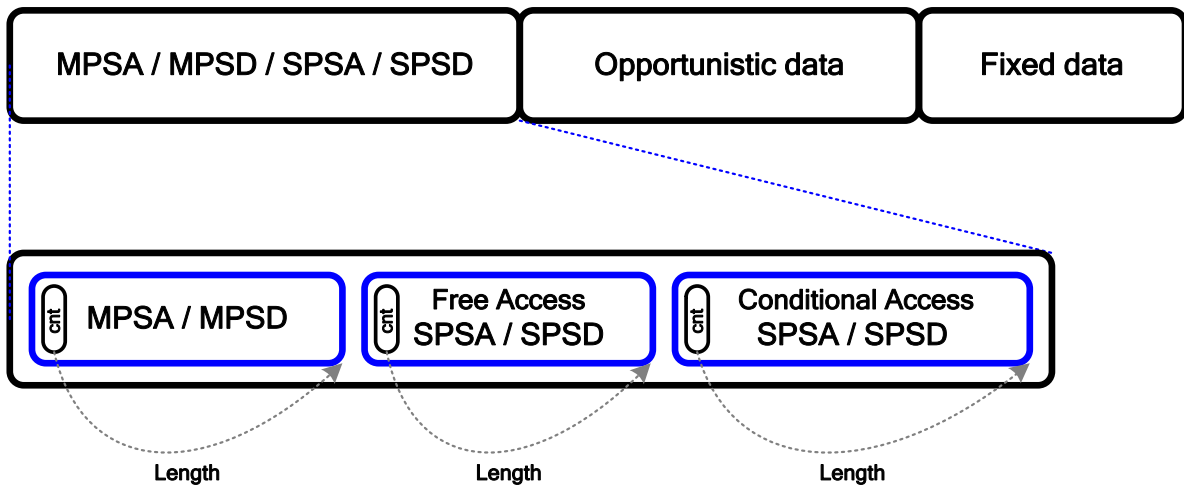

Figure 5-4: Layer 2 Order of Multiple Instances of Audio-Oriented Content

MPS transport is always placed first, starting with Layer 2 bit 0. MPS transport is then followed by instances of SPS transport that contain audio that is free-access. Instances of SPS transport that contain audio that is conditionally-accessed are placed last, toward the end of the audio-oriented content. The audio-oriented transport instances are independent. Each instance contains its control information that

points to the end of the PDU. Therefore, the control information of the last audio instance points to the end of the entire audio-oriented content.

Data-oriented content (for services) may include opportunistic data services transport and fixed data services transport. Figure 5-5 provides a detailed description of certain order requirements within the data services content in Layer 2. Note that if there is no opportunistic data being sent, the DDL field shall not be sent either.

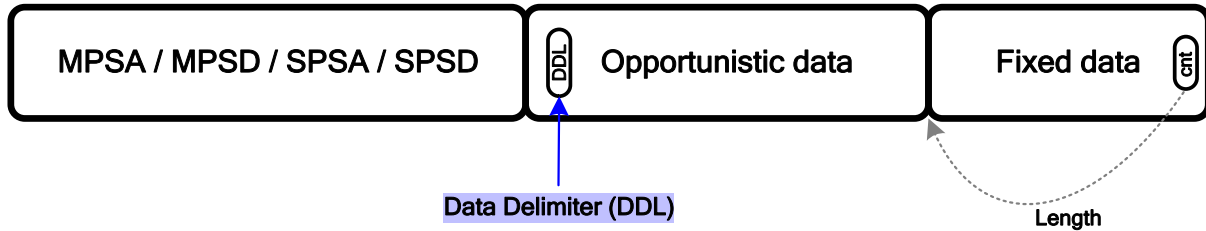

Figure 5-5: Layer 2 Order of Data Content Control Information

The fixed data services transport PDU is always placed towards the last bit of the Layer 2 PDU. The fixed data transport control information, which is included within the fixed data PDU, points to the end of that PDU.

The opportunistic data PDU immediately follows (counting down bitwise) the fixed data PDU. It may span any instantaneous length and does not necessarily fill the entire gap (i.e., it does not necessarily utilize the instantaneously available bandwidth) towards the audio content. The end of the opportunistic data PDU (lower end bitwise count) is indicated by a Data Delimiter (DDL).

6 Layer 2 Processing

6.1 Transmit Processing Description

For each active Layer 1 logical channel, Layer 1 indicates to Layer 2 that it requires an L2 PDU. Based on the parameters defined in the previous section, L2 indicates to the Audio Transport and the AAS Data Transport (AAT) to provide their respective PDUs (MPS, SPS PDU, and AAS PDU) that are to be multiplexed within the L2 PDU to that specific Layer 1 logical channel.

Once Layer 2 has received the input PDUs, it creates the L2 PDU to be sent to the appropriate Layer 1 logical channel by:

1. Creating Layer 2 PCI based on content and encoding
2. Spreading PCI across an L2 PDU
3. Inserting MPS/SPS and AAS PDUs into an L2 PDU around the spread PCI

The upper layers notify L2 what information is available to it.

For a PIDS or SIDS Layer 1 logical channel, Layer 1 indicates to Layer 2 that it requires an L2 PDU. Layer 2 indicates to the SIS Transport to provide its respective PDU. Layer 2 forwards the SIS PDU directly to Layer 1 without any modification.

The HD Radio system provides SIS to all HD Radio receivers. The PIDS and SIDS logical channels are dedicated to transporting SIS that may be acquired quickly for initial screening of provided services and other station-related information.