



HD Radio™ Air Interface Design Description Audio Transport

Rev. H
December 14, 2016

TRADEMARKS

HD Radio™ and the HD, HD Radio, and “Arc” logos are proprietary trademarks of iBiquity Digital Corporation.

“iBiquity”, “iBiquity Digital”, and the iBiquity Digital logo are also proprietary trademarks of iBiquity.

All other trademarks, whether claimed or registered, are the exclusive property of their respective owners.

iBiquity Digital Corporation

6711 Columbia Gateway Drive, Suite 500

Columbia, MD 21046

Voice: 443-539-4290

Fax: 443-539-4291

E-mail address:

info@ibiquity.com

Table of Contents

Contents

1	SCOPE	1
1.1	System Overview.....	1
1.2	Document Overview.....	1
2	REFERENCE DOCUMENTS	2
3	ABBREVIATIONS AND CONVENTIONS	3
3.1	Introduction	3
3.2	Abbreviations and Acronyms	3
3.3	Presentation Conventions	4
3.4	Mathematical Symbols	4
3.4.1	Variable Naming Conventions	4
3.4.2	Arithmetic Operators.....	5
3.4.3	Data Constant Formats	5
4	AUDIO TRANSPORT – DETAILED DESIGN DESCRIPTION	6
4.1	Introduction	6
4.2	Audio Encoder.....	8
4.3	Audio Transport.....	10
4.3.1	Blending	11
4.3.2	Additional Delay Compensation	11
4.4	Data Transport Interface	13
4.4.1	Program Service Data.....	13
4.4.2	Opportunistic Data	13
5	PROTOCOL DATA UNIT	14
5.1	Protocol Data Unit Configuration.....	14
5.2	PDU Characteristics	14
5.2.1	PDU Structure	14
5.2.1.1	Audio Codec Mode	19
5.2.1.2	Blend Control.....	21
5.2.1.3	TX Digital Audio Gain.....	22
5.2.1.4	Header Expansion Flag	22
5.2.1.5	Locator Fields	22
5.2.1.6	Header Expansion Fields.....	24
5.2.1.6.1	Class Indication.....	26
5.2.1.6.2	Program Number Indication.....	27
5.2.1.6.3	Program Type Indication.....	28
5.2.1.6.4	Reserved Header Expansion.....	29
5.2.1.6.5	PDU Marker Indication.....	30
5.2.2	Program Service Data (PSD) Processing.....	32
5.2.3	Error Control Codes	33
5.2.3.1	Packet Header Protection	33

5.2.3.2	Packet Integrity Control	33
5.2.4	Audio Encryption	34
5.2.4.1	Marker Timing	34
5.2.4.2	Encoded Audio Packet Encryption.....	34
GLOSSARY	35

List of Figures

Figure 4-1: Audio Transport Interface Diagram	7
Figure 4-2: Transmit Audio Encoder Interface	8
Figure 4-3: Elastic Buffering Example	10
Figure 4-4: Audio Transport Block Diagram.....	11
Figure 4-5: Audio Encoder/Decoder as a Constant Delay Element for the System	11
Figure 5-1: PDU Format	15
Figure 5-2: PDU Control Word – Bit Allocation for Codec Modes 0b0000 through 0b1110	16
Figure 5-3: PDU Control Word – Bit Allocation for Codec Mode 0b1111 (15)	16
Figure 5-4: Locator Fields – 16-Bit	23
Figure 5-5: Locator Fields – 12-Bit	23
Figure 5-6: Header Expansion Fields – Example.....	25
Figure 5-7: Header Expansion – Class Indication.....	26
Figure 5-8: Header Expansion – Program Number Indication.....	27
Figure 5-9: Header Expansion – 2-byte Expansion	27
Figure 5-10: Header Expansion – Program Type.....	28
Figure 5-11: Header Expansion – Program Segment ID.....	29
Figure 5-12: Header Expansion – PDU Marker.....	30

List of Tables

Table 5-1: PDU Header Field Definitions	16
Table 5-2: Audio Codec Mode Definitions	19
Table 5-3: Backward Compatibility of Reserved Audio Codec Modes – Defaults	20
Table 5-4: Blend Control Bit Definitions.....	21
Table 5-5: TX Digital Audio Gain Control.....	22
Table 5-6: Header Expansion Field Bits – Definitions	24
Table 5-7: Class Indications.....	26
Table 5-8: Applied Services Indication.....	31
Table 5-9: Program Service Data per Audio Codec Mode	32

1 Scope

1.1 System Overview

iBiquity Digital Corporation's HD Radio™ system is designed to permit a smooth evolution from current analog amplitude modulation (AM) and frequency modulation (FM) radio to a fully digital in-band on-channel (IBOC) system. This system delivers digital audio and data services to mobile, portable, and fixed receivers from terrestrial transmitters in the existing medium frequency (MF) and very high frequency (VHF) radio bands. Broadcasters may continue to transmit analog AM and FM simultaneously with the new, higher-quality and more robust digital signals, allowing themselves and their listeners to convert from analog to digital radio while maintaining their current frequency allocations.

1.2 Document Overview

This document describes the design and capabilities of the audio transport. It describes how control and information are passed through this transport. This document also details the requirements imposed on the audio codec by the design of the overall HD Radio system. Specific hardware and software implementations are not described.

2 Reference Documents

STATEMENT

Each referenced document that is mentioned in this document shall be listed in the following iBiquity document:

- * Reference Documents for the NRSC In-Band/On-Channel Digital Radio Broadcasting Standard
Document Number: SY_REF_2690s

3 Abbreviations and Conventions

3.1 Introduction

Section 3 provides the following:

- Abbreviations and Acronyms
- Presentation Conventions
- Mathematical Symbols

3.2 Abbreviations and Acronyms

AAS	Advanced Application Services
AF	Audio Frame
AM	Amplitude Modulation
C	Center
CRC	Cyclic Redundancy Check
ECPL	Embedded Code PDU Length
FM	Frequency Modulation
GF	Galois Field
IBOC	In-Band On-Channel
ID	Identification
L	Left
MF	Medium Frequency
MPS	Main Program Service
MPSA	Main Program Service Audio
N/A	Not Applicable
NOP	Number of Packets
PCI	Protocol Control Information
PCM	Pulse Code Modulation
PDU	Protocol Data Unit
PSD	Program Service Data
R	Right
RBDS	Radio Broadcast Data System
RS	Reed-Solomon
RX	Receiver
SPS	Supplemental Program Service
SPSA	Supplemental Program Service Audio
VHF	Very High Frequency

3.3 Presentation Conventions

Unless otherwise noted, the following conventions apply to this document:

- All vectors are indexed starting with 0.
- The element of a vector with the lowest index is considered to be first.
- In drawings and tables, the leftmost bit is considered to occur first in time.
- Bit 0 of a byte or word is considered the least significant bit.
- When presenting the dimensions of a matrix, the number of rows is given first (e.g., an n x m matrix has n rows and m columns).
- In timing diagrams, earliest time is on the left.
- Binary numbers are presented with the most significant bit having the highest index.
- In representations of binary numbers, the least significant bit is on the right.

3.4 Mathematical Symbols

3.4.1 Variable Naming Conventions

The variable naming conventions defined below are used throughout this document.

Category	Definition	Examples
Lower and upper case letters	Indicates scalar quantities	i, j, J, g ₁₁
Underlined lower and upper case letters	Indicates vectors	<u>u</u> , <u>V</u>
Double underlined lower and upper case letters	Indicates two-dimensional matrices	<u><u>u</u></u> , <u><u>V</u></u>
[i]	Indicates the i th element of a vector, where i is a non-negative integer	<u>u</u> [0], <u>V</u> [1]
[]	Indicates the contents of a vector	<u>v</u> = [0, 10, 6, 4]
[i] [j]	Indicates the element of a two-dimensional matrix in the i th row and j th column, where i and j are non-negative integers	<u>u</u> [i][j], <u>V</u> [i][j]
[]	Indicates the contents of a matrix	<u><u>m</u></u> = $\begin{bmatrix} 0 & 3 & 1 \\ 2 & 7 & 5 \end{bmatrix}$
n ... m	Indicates all the integers from n to m, inclusive	3 ... 6 = 3, 4, 5, 6
n:m	Indicates bit positions n through m of a binary sequence or vector	Given a binary vector i = [0, 1, 1, 0, 1, 1, 0, 0], i _{2:5} = [1, 0, 1, 1]
NOP	No. of Packets	NOP=64

3.4.2 Arithmetic Operators

The arithmetic operators defined below are used throughout this document.

Category	Definition	Examples
.	Indicates a multiplication operation	$3 \cdot 4 = 12$
INT()	Indicates the integer portion of a real number	INT(5/3) = 1 INT(-1.8) = -1
a MOD b	Indicates a modulo operation	$33 \text{ MOD } 16 = 1$
\oplus	Indicates modulo-2 binary addition	$1 \oplus 1 = 0$
	Indicates the concatenation of two vectors	$\underline{A} = [\underline{B} \mid \underline{C}]$ The resulting vector \underline{A} consists of the elements of \underline{B} followed by the elements of \underline{C} .
j	Indicates the square-root of -1	$j = \sqrt{-1}$
Re()	Indicates the real component of a complex quantity	If $x = (3 + j4)$, $\text{Re}(x) = 3$
Im()	Indicates the imaginary component of a complex quantity	If $x = (3 + j4)$, $\text{Im}(x) = 4$
log ₁₀	Indicates the base-10 logarithm	$\log_{10}(100) = 2$
ceil(numeric)	Smallest integer not less than argument	$\text{ceil}(-42.8) = -42$

3.4.3 Data Constant Formats

The data constant formats defined below are used throughout this document.

Category	Definition	Examples
0b	Indicates a binary number	0b1111 = 15 (decimal)
0x	Indicates a hexadecimal number	0xFF = 255 (decimal)

4 Audio Transport – Detailed Design Description

This section describes the Audio Transport design, emphasizing its operations, processing, and interfacing of the audio encoder within the Audio Transport layer. The following broad system concepts are presented:

- Maintaining the fixed and variable encoding rates of the Audio Encoder
- Audio Transport delay control
- *Audio Frame* (AF) size and number
- Time alignment of analog and digital signals
- Data transport

Detailed audio encoder interface descriptions are organized in a functional sense to present guidelines for audio compression systems operating within the iBiquity HD Radio system.

All the bit rates mentioned in this document are “transport” rates which include the net codec rate and all applicable overhead. Also, the audio clock is derived from the broadcast system clock.

Note: All aspects of the Audio Transport design in this document also apply to the Supplemental Program Service (SPS) and the generation of SPS PDUs unless mentioned otherwise. Each audio program has its own individual PDU.

4.1 Introduction

Figure 4-1 shows the interface of the Audio Transport layer to the rest of HD Radio system. During broadcast, the Audio Encoder receives input audio frames from the Audio Interface, encodes the audio samples into encoded audio packets, generates PDUs in the Audio Transport, and conveys the PDUs as output data streams to be transmitted. In addition, the Audio Transport obtains Program Service Data (PSD) byte-streams, if present, from the PSD Transport [10] and multiplexes this data with encoded audio. Thus, the output streams contain both encoded audio and PSD. PSD provides additional information about the audio program being transmitted; both the Main Program Service Audio (MPSA) and the Supplemental Program Service Audio (SPSA).

The Audio Encoder may generate one or two encoded audio streams (core and enhanced), depending on the audio codec mode as indicated by the dotted lines in Figure 4-1. Finally, the audio encoder indicates the amount of unused capacity to the Audio Transport, which relays the unused capacity status to the AAS Transport [5], thus allowing for the inclusion of opportunistic data. The definitions of the units used for data transfer – audio frames, encoded audio packets, PDUs – within the Audio Transport layer are explained in the Glossary.

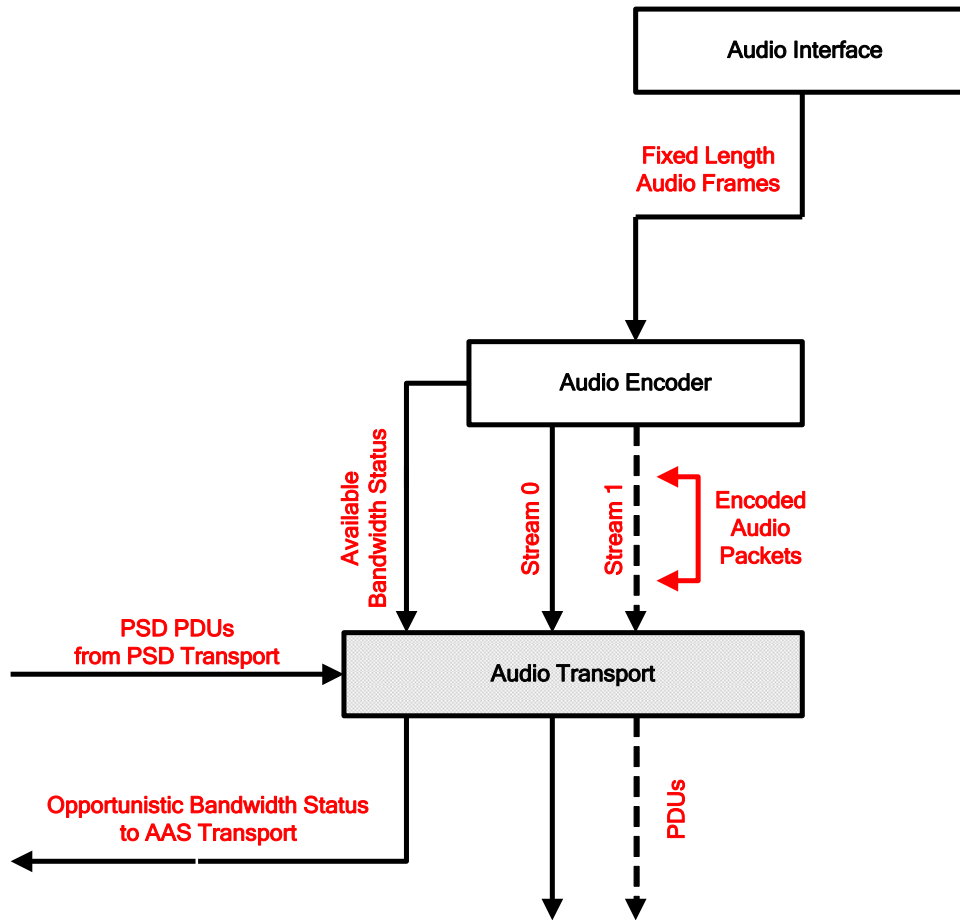

Figure 4-1: Audio Transport Interface Diagram

4.2 Audio Encoder

The Audio Encoder is a block-processing algorithm; each block or audio frame corresponds to 2048 input samples from each channel (for example, left and right), regardless of the number of channels. However, the audio codec may be a variable bit rate process. In this case, each input audio frame corresponds to a variable length output encoded audio packet. Therefore, the codec must also employ a built-in rate-control mechanism so that these packets can easily be transmitted over a constant capacity channel. The rate-control mechanism works in conjunction with suitable buffering within the audio codec. The audio codec rate-control and buffer-control mechanisms ensure that the implemented buffering is sufficient (that is, the buffers will not overflow or underflow). With these mechanisms, the audio codec may be treated as a fixed rate codec with a specified constant delay between the input and the output.

Although the encoded audio packet size variability has an impact on the system in terms of variable tuning delay (smaller packets can be decoded faster than longer packets), there is almost no additional cost for the system in terms of increased system complexity. The packet size variability is essentially invisible to the other parts of the system and manifests itself only in terms of an additional constant audio codec delay.

The Audio Transport supports a multi-stream codec. The HD Radio system may utilize multi-stream audio transmission to provide robust coverage and fast tuning times. A multi-stream Encoder segregates the encoded audio content into separate bit-streams. The “more important” encoded bits are placed in a *core* bit-stream such that it is independently decodable, albeit at reduced audio quality. The remaining bits are placed in an *enhanced* bit-stream which will, when combined with the core bit-stream at the decoder, produce an audio output at a level of quality that is substantially identical to that of a decoded single stream at a bit rate equivalent to the total bit rate of the core and enhanced bit-streams. The enhanced bit-stream is not independently decodable.

Audio frames are received from the Audio Interface and are processed by the Audio Encoder. Based on the configuration, encoded audio packets are written to a separate memory buffer for each Audio Encoder output stream. Figure 4-2 shows the Audio Encoder Interfaces. The encoded audio packets are sent to the Audio Transport.

The peak audio level shall be matched to the implemented audio codec to prevent clipping and other distortion. The exact audio level is dependent on the codec specifications.

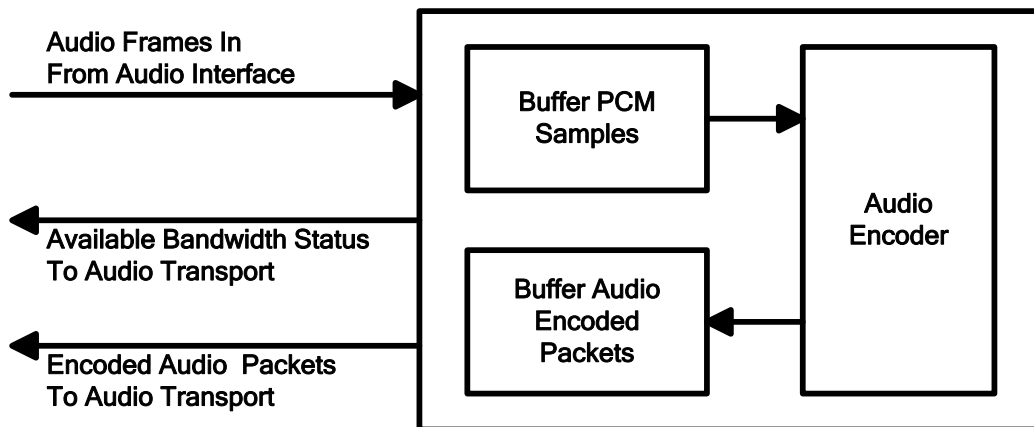

Figure 4-2: Transmit Audio Encoder Interface

The Audio Encoder is flexible in format and bit rate scaling. It provides high quality, efficient audio compression over a variety of formats from 8.1-kbit/s for a monophonic channel to 96-kbit/s for a stereo

audio format. The audio transport also provides a fixed rate Program Service Data byte-stream channel and supports variable rate opportunistic data channel.

4.3 Audio Transport

The Audio Transport accepts the variable length encoded audio packets from the Audio Encoder and packs them into fixed length PDUs. On average, the number of encoded audio packets per PDU is N . Refer to Table 5-2 for the value of N for different audio codec modes. However, this may vary by an elastic-buffer size parameter, D , from one PDU to another to account for the packet size variability. Denoting the number of encoded audio packets per PDU as n , the number of packet per PDU will be within the range $(N-D) \leq n \leq (N+D)$. For example, if $N=32$ and $D=8$, each PDU may contain from 24 to 40 encoded audio packets (frames), with an average of 32 packets (frames) per PDU. Figure 4-3 illustrates this example. It must be noted that the PDU bit length has a maximum size based on the L1 rate and the codec rate. However, the number of encoded audio packets is variable to accommodate extra throughput per packet. The parameter D is sent over-the-air as part of the PDU and is used to determine the amount of buffering needed at the Audio Decoder to make the encode/decode process appear as a fixed delay process. Sequence numbers are also sent over the air so that the audio decoder can perform proper alignment between multiple streams.

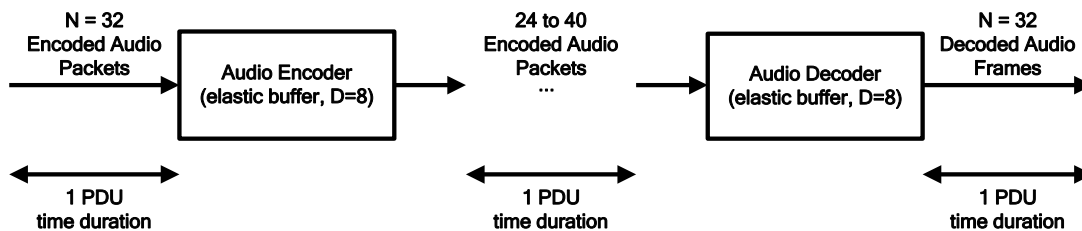

Figure 4-3: Elastic Buffering Example

PDUs are always produced in time units of 4 or 32 input audio frames. In some audio codec modes, multiple encoded audio streams are produced. The PDU rate may be different for each of the streams; for example, 4 audio frame times for the core stream and 32 audio frame times for the enhanced stream. In this example, a valid enhanced PDU will be generated only once for every eight valid core PDUs.

In generating a PDU, the encoded audio packets are buffered until an encoded output unit is complete (after 4 or 32 input audio frame times) and a PDU is constructed with a maximum length determined by the configuration, as shown in Figure 4-4.

At the receiver, the encoded audio packets for each stream (core and enhanced streams must be aligned) are input to the Decoder. The Audio Decoder then decodes and outputs the N audio frames contained within the encoded audio packets. This assumes that the rate control mechanism for the codec variability is implemented within the Decoder. In addition, appropriate buffering of encoded audio packets is implemented by the Audio Transport such that a constant delay is maintained through the encode/decode process.

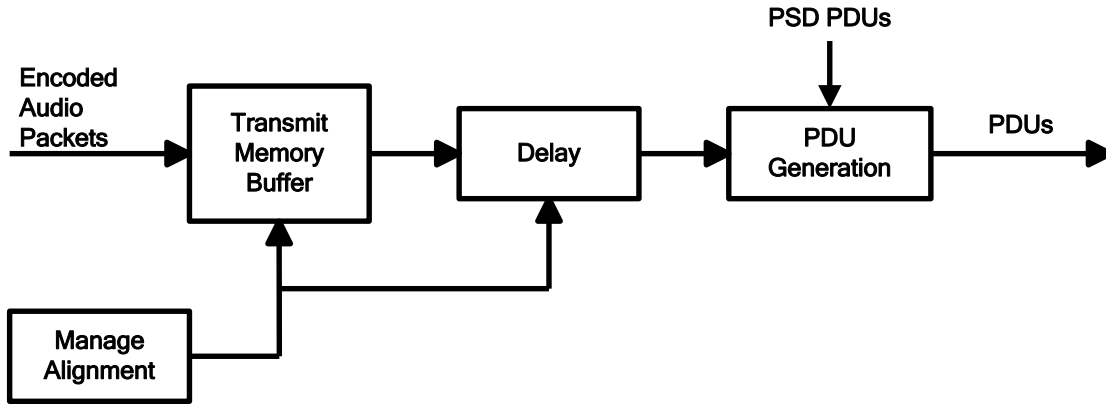

Figure 4-4: Audio Transport Block Diagram

4.3.1 Blending

The blend mechanism in the Hybrid AM and Hybrid FM systems accurately aligns the analog signal and the digital signal in time. The interface shown in Figure 4-5 allows the Audio Decoder in the receiver to be treated as a constant delay element. In other words, the time between providing MPS PDU data to the Decoder and corresponding output audio generation (that is, the audio for which the Encoder returned this MPS PDU) is a constant D (exclusive of Decoder implementation delay, Δ), as selected by the encoder. Typical Decoder delays include processing delay and error mitigation delay.

The delay is constant irrespective of the start (tune-in) time at the Decoder or the characteristics of the audio system. It is also constant regardless of the nature of the audio or the starting MPS PDU at the decoder.

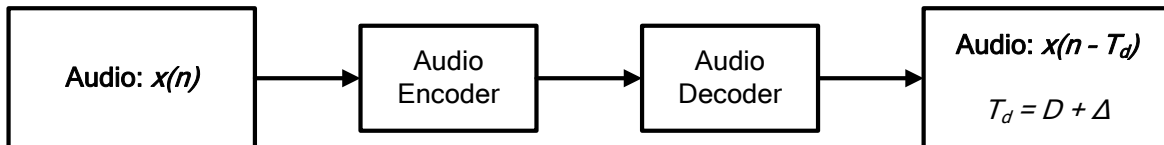

Figure 4-5: Audio Encoder/Decoder as a Constant Delay Element for the System

Another form of blending in the Hybrid AM and Hybrid FM systems applies to SPS. For SPS, no specific time alignment is required, as the blend involves transition between audio and silence.

4.3.2 Additional Delay Compensation

The Audio Transport interface must support a provision for additional delay compensation both at the transmitter and the receiver. This is in addition to the automatic delay compensation inherent in the Audio Decoder related to the frame size variability. At the transmitter, this compensation may be requested in units of PDUs, in which case the encoded audio stream is delayed by the corresponding number of PDUs prior to being sent. Additional delay compensation may be requested in the units of audio samples, and the decoded audio stream is delayed by that amount.

Another case requiring proper handling of delay information on both the encoding side and the decoding side involves multi-stream programs. The enhanced stream must be aligned with the core stream; otherwise audio distortion may occur at the decoder output. In the case of multi-stream programs, the core

stream is the base audio stream (where delay parameters are irrelevant) and only the enhanced stream carries relevant delay information.

4.4 Data Transport Interface

The Audio Transport provides a mechanism (byte-oriented) for opportunistic and PSD capability. The Audio Transport mechanism consists of: the following:

- Interface for injecting PSD into a PDU at the Encoder.
- Notification mechanism for Encoder-side entity (when more data is needed).
- Notification mechanism for Encoder-side entity of unused capacity.

4.4.1 Program Service Data

The audio codec PSD facility is a variable byte-stream and exists (although it is not necessarily used) for each defined audio stream. A PSD byte-stream may be added to each individual PDU in time-varying amounts. This is enabled through the PSD Transport [10]. Refer to Subsection 5.2.2 for details on PSD processing.

4.4.2 Opportunistic Data

The audio encoder provides a mechanism to indicate any unused byte-oriented capacity within the MPS PDU or the SPS PDU which is then made available for other data applications in the HD Radio system. The unused byte capacity as determined by the audio encoder is available for use by the AAS Transport and the transmission of opportunistic data services. The unused capacity is indicated per encoded stream. The unused bandwidths from MPS and SPS in each logical channel are aggregated for this service. This bandwidth is allocated on a PDU-per-PDU basis and may not be available in every consecutive PDU. The data rates for Audio Encoder opportunistic data streams are heavily dependent on the audio program, and may vary from zero to several kbit/s.

The Available Bandwidth Status indication is dependent on the actual system software implementation. The HD Radio system developed by iBiquity provides the size of each encoded audio packet in each stream to other processes in the transmission system.

5 Protocol Data Unit

5.1 Protocol Data Unit Configuration

In order to achieve efficiency with respect to system throughput and data bandwidth, it is assumed that the Audio Transport derives certain configuration information through administrative primitives. Such configuration information is derived from other parts of the system, such as the Audio Interface at the transmitter or in the process of relaying PDUs to the Audio Transport at the receiver. This configuration is affected by the primary service mode of the system. All bit rates, as indicated in tables and figures in this section, are approximate and usually rounded to the nearest thousand.

Once the desired configuration information is available, the Audio Transport (at the transmitter) accepts audio samples at the Audio Interface and converts them into a PDU.

5.2 PDU Characteristics

The exact handling of the audio frames and the resulting PDU is uniquely defined by a combination of audio codec mode and stream number. That combination is included in the PDU information for retrieval and proper handling by the audio decoder.

5.2.1 PDU Structure

Figure 5-1 illustrates the PDU format for all audio codec modes. This PDU format includes a fixed header portion (that includes the RS parity bytes and the PDU Control Word), a variable number of audio packet location fields (Loc 0, Loc 1, ..., Loc NOP-1), an optional Header Expansion field, PSD field, and encoded audio packets. The PDU Control Word is protected by a 96-byte Reed-Solomon (RS) codeword. Since the RS codeword is a fixed size it may also span portions of the Header Expansion field, PSD field, and possibly the encoded audio packets.

Each PDU consists of RS parity bytes, the PDU Control Word, the audio packet location fields (locators), optional Header Expansion, and a variable number of encoded audio packets. Each locator (Loc) points to the CRC byte that follows the packet that it covers, using one locator per packet. The size of the locator fields (Lc bits) is a variable and is optimized (matched) to the PDU length to reduce overhead. Each encoded audio packet is protected by an 8-bit CRC field.

The internal buffer control mechanism of the Audio Encoder handles the fractional packet scenario (where the first or last packet generally spans across two PDUs). This scenario is necessary to ensure that the PDU is of a certain maximum size. The Audio Transport ensures that this is transparent to other layers. The first byte of the PDU is defined as byte 0; the last byte of the PDU depends on the variable size of the PDU.

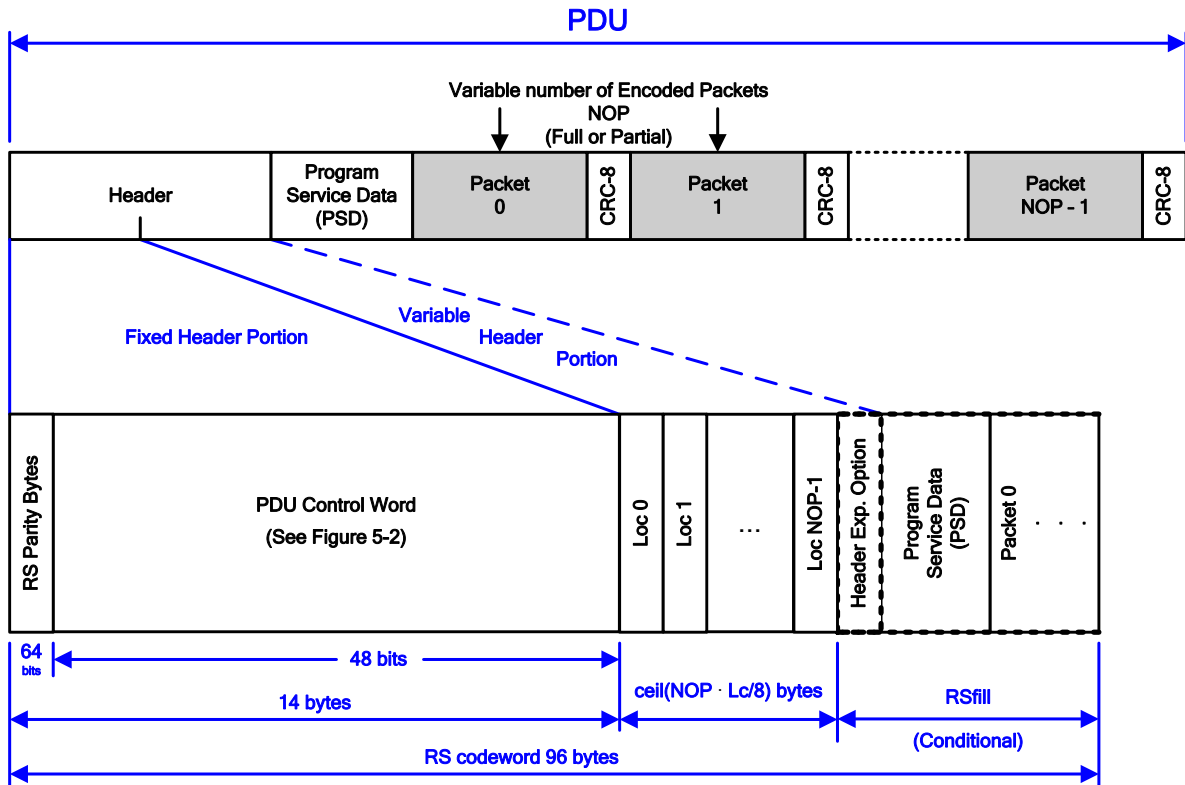

Figure 5-1: PDU Format

The fields enclosed by the dotted lines (Header Expansion, PSD, portion of encoded audio packets) are part of the RS codeword only conditionally. The overall length of the RS parity, PDU control word, and audio packet locators may be less than the 96-byte RS codeword. When this case occurs, additional fields (Header Expansion, PSD, and Packet 0) fall within the 96-byte RS codeword and will be included in the RS parity byte computation.

Figure 5-2 shows the PDU control word. It shows the bit allocation within the PDU control word and the bit aggregation into bytes.

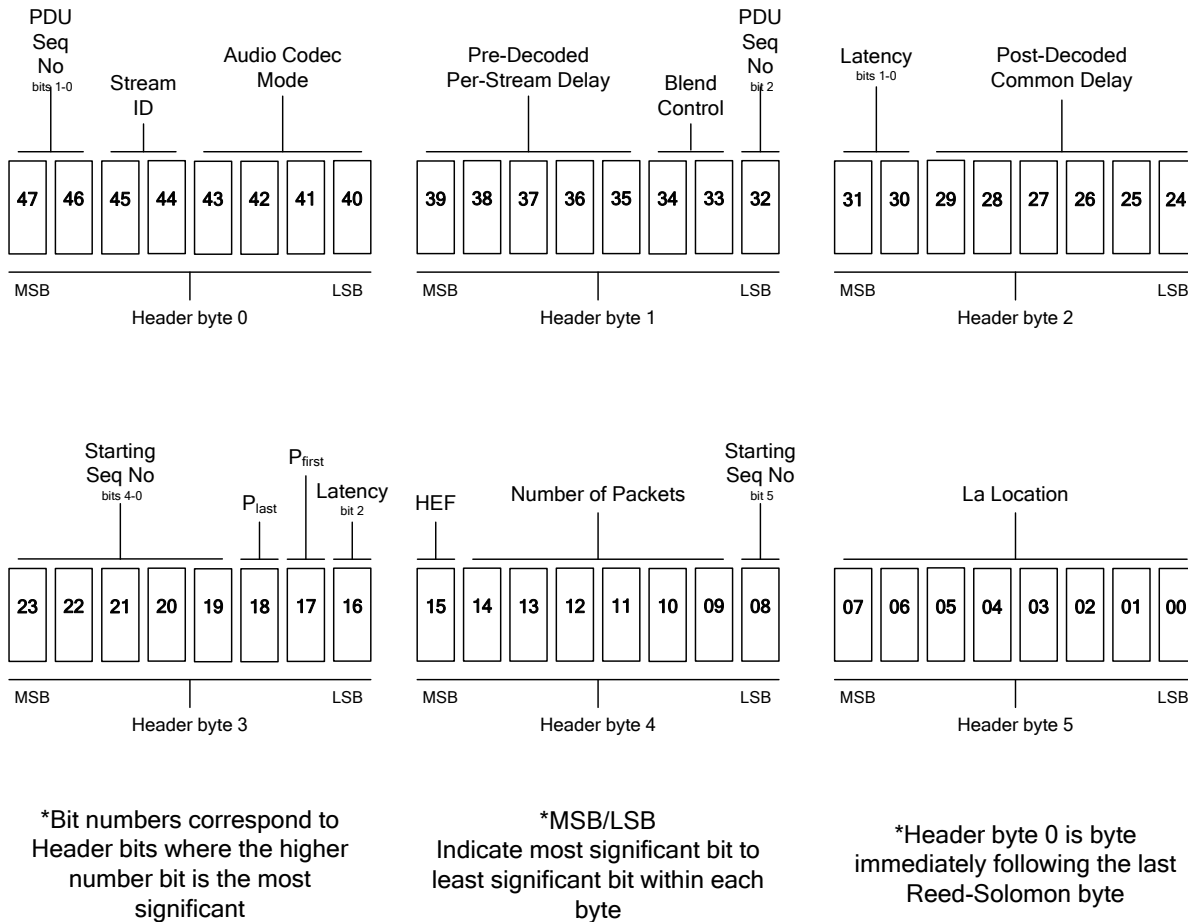

Figure 5-2: PDU Control Word – Bit Allocation for Codec Modes 0b0000 through 0b1110

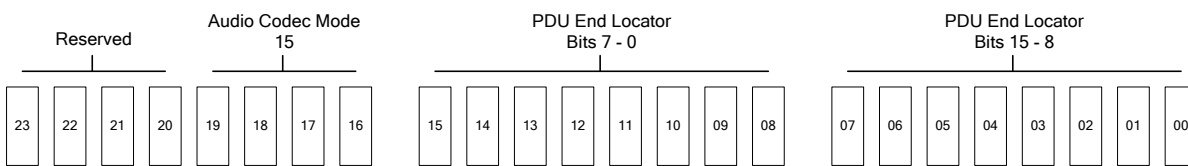

Figure 5-3: PDU Control Word – Bit Allocation for Codec Mode 0b1111 (15)

Details of the PDU format for Codec Modes 0b0000 (zero) through 0b1111 (15) are presented in Table 5-1 and the ensuing subsections.

Table 5-1: PDU Header Field Definitions

Bits	Field Name/Description	Comments
64	Parity Bits	Eight RS parity bytes for header error protection
4	Audio Codec Mode	See Table 5-2. This parameter must be set to the same value for all streams.

Bits	Field Name/Description	Comments
2	Stream ID	This field is used to indicate the stream type Core (0b00) Enhanced (0b01) Reserved (0b10) and (0b11)
3	PDU Sequence Number	This is the sequence number of the PDU It increments by one modulo the sequence number range (as defined in Table 5-2) every PDU
2	Blend Control	This field must be set to the same value for all streams. Refer to Table 5-4. For SPS PDUs, this field must be set to 0b00.
5	TX Digital Audio Gain Pre-decoded Per Stream Delay	If Stream ID = 0b00, this field defines the TX Digital Audio Gain (see Table 5-5). For all other Stream IDs, this field defines the delay between this corresponding stream and stream 0b00. Stream 0b00 is never delayed but the corresponding stream is delayed. This delay (in units of four-audio-frame periods) is that which the receiver is to normally apply prior to audio decoding.
6	Post-decoded Common Delay	Delay (in units of four-audio-frame periods) that the receiver uses to align the digital audio content with the associated analog audio content after audio decoding. This field must be set to the same value for all streams.
3	Latency	Audio codec latency (in units of two-audio-frame periods); the value is limited to a maximum value of 10. This value constrains the total audio encoder/decoder delay to a fixed value. This parameter excludes any decoder implementation delays and is equivalent to the elastic buffer depth, D. This field must be set to the same value for all streams.
1	P _{first} Flag	First Packet Partial P _{first} is set to 0b1 if the first encoded audio packet of the PDU is a continuation from the last PDU.
1	P _{last} Flag	Last Packet Partial P _{last} is set to 0b1 if the last encoded audio packet of the PDU will continue into the next PDU.
6	Starting Sequence Number	Sequence number of the encoded audio packet in the PDU following the first partial packet, if any. Initialized to zero for all streams simultaneously; the range is 0 to 63.
6	Number of Packets (NOP)	Number of encoded audio packets contained within the PDU, full and partial.
1	Header Expansion Flag (HEF)	Header Expansion Flag is set to 0b1 when the optional Header Expansion Field is inserted immediately following the Location Fields.
8	La Location	Location of last byte of the Program Service Data field. The location is relative to the first byte (Byte 0) of the PDU.

Bits	Field Name/Description	Comments
NOP·Lc	Locator fields	Each of the NOP pointers consisting of Lc bits points to location of last byte (CRC location) of the corresponding packet for each of the NOP packets (partial or full) in the PDU. The location is relative to the first byte (Byte 0) of PDU.
0 - 128 (optional)	Header Expansion Field(s) (optional)	Header Expansion Field present only when Header Expansion Flag (HEF) is set to 0b1. See Table 5-6 for format.
RSfill (Conditional)	Start at byte 14 + ceil(NOP·Lc/8) + (Number of Header Expansion Fields) through byte 95	This field extends to the end of the 96-byte RS codeword. Bytes include the start of Expansion bytes, PSD field, followed by encoded audio packets when the Expansion bytes and PSD do not extend to the RS codeword length (96 bytes).

The PDU header for codec mode 0b1111 (15) is shown in Figure 5-3. It includes the indication of the codec mode itself, followed by a 16-bit “PDU end locator” that points to the end of the PDU (i.e., the last byte of the PDU). The end of the PDU refers to the first byte of the PDU as byte number 0 (zero).

5.2.1.1 Audio Codec Mode

Table 5-2 defines the FM and AM audio codec modes according to stream configuration, PDU configuration, and bit rates. Table 5-2 shows the maximum bit rate for each codec mode in the context indicated by the “Typical Use” column. Note that higher bit rates may need to be allocated within the broadcast system in order to account for additional overhead, such as the audio header information.

The codec bit rate may be scaled back to a value less than the maximum rate. The minimum bit rate is dependent on the actual codec implementation and as well as the desired minimum acceptable audio quality. As technology improves, it may be possible that for a given level of audio quality, the bit rate can be reduced. Hence this document does not impose specific minimum bit rates for each codec mode. This is left as an implementation detail.

For two-stream audio codec modes, the broadcast system may further lower the configured bit rate by not using the enhanced stream.

Single-stream audio codec modes may contain a monaural (mono) or two-channel audio (stereo) signal. This also applies to two-stream systems when both streams are valid at the decoder input. The core audio stream of a two-stream signal that is valid at the decoder input may be either stereo or mono depending on the audio codec mode and the configured bit rate. A monophonic signal (L and R) is always decoded or presented as a dual-mono (that is, identical left and right channels) signal by the audio decoder.

Table 5-2: Audio Codec Mode Definitions

Audio Codec Mode	Typical Use	Number Of Streams	Stream ID	Stream Type Core or Enhanced)	PDUs Per L1 Frame	Average Number of Encoded Audio Packets Per PDU (N)	PDU Sequence Number Range	Lc bits Per Location	Maximum Bit Rate (kbit/s)
0b0000	FM Hybrid	1	00	Core	1	32	0 - 1	16	96
0b0001	FM All Digital	2	00	Core	8	4	0 - 7	12	48
			01	Enhanced	1	32	0 - 1	16	48
0b0010	AM Hybrid	2	00	Core	8	4	0 - 7	12	20
			01	Enhanced	1	32	0 - 1	16	16
	AM All Digital	2	00	Core	8	4	0 - 7	12	20
			01	Enhanced	1	32	0 - 1	16	20
0b0011	FM All Digital	2	00	Core	8	4	0 - 7	12	24
			01	Enhanced	1	32	0 - 1	16	72
0b0100 to 0b1001	Reserved								
0b1010	FM Hybrid / All Digital	2	00	Core	1	32	0 - 1	12	22
			01	Enhanced	8	4	0 - 7	12	24

Audio Codec Mode	Typical Use	Number Of Streams	Stream ID	Stream Type Core or Enhanced)	PDU's Per L1 Frame	Average Number of Encoded Audio Packets Per PDU (N)	PDU Sequence Number Range	Lc bits Per Location	Maximum Bit Rate (kbit/s)
0b1011 to 0b1100	Reserved								
0b1101	FM Hybrid / All Digital	1	00	Core	8	4	0 - 7	12	24
0b1110	Reserved								
0b1111	Reserved								

The audio codec output bit-rate can be scaled to provide additional capacity for other applications. The audio codec throughput is limited by the maximum PDU lengths for the different service modes as specified in [1] and [2].

Table 5-2 shows audio codec modes that are not yet defined. However, all future audio codec modes must maintain backward compatibility with certain streams of the defined modes.

Table 5-3 shows the stream compatibility for all the reserved codec modes.

Table 5-3: Backward Compatibility of Reserved Audio Codec Modes – Defaults

Audio Codec Mode	Default Audio Mode	Backward Compatible Streams	Stream Free to be Redefined [†]
0b0100	0b0010	0b00, 0b01	None
0b0101	0b0010	0b00, 0b01	None
0b0110	0b0010	0b00	0b01
0b0111	0b0010	0b00	0b01
0b1000	0b0000	0b00	None
0b1001	0b0011	0b00, 0b01	None
0b1011	0b0011	0b00	0b01
0b1100	0b0001	0b00, 0b01	None
0b1110	0b0001	0b00	0b01
0b1111	None	None	All

[†] Additional streams are assumed in expanded All Digital system service modes and possibly in advanced (future) hybrid configuration.

5.2.1.2 Blend Control

Table 5-4 defines the blend control bits. This definition only applies to the Main Program Service Audio (MPSA); for any Supplemental Program Service Audio (SPSA) the bits are set to 0b00.

Table 5-4: Blend Control Bit Definitions

Audio Control Word Bit 34	Audio Control Word Bit 33	Waveform	Service Mode	Definition
0	0	AM and FM Hybrid	MP1 MP2 MP3 MP11 MA1	Not Valid 0b00 shall never be sent in the MPSA PDUs in hybrid service modes. This can cause undefined behavior in various receiver models.
		AM and FM All Digital	MP5 MP6 MA3	No analog diversity delay has been applied by the transmitter. RX shall disable analog blending. This should always be sent by the broadcaster when in any all digital service mode.
0	1	AM and FM Hybrid FM Extended Hybrid	MP1 MP2 MP3 MP11 MA1 MP5 MP6	No analog diversity delay has been applied by the transmitter. RX shall disable analog blending.
		AM and FM All Digital	MP5 MP6 MA3	Not Valid
1	0	AM and FM Hybrid	MP1 MP2 MP3 MP11 MA1	Analog diversity delay has been applied by the transmitter. RX shall blend to analog when the digital audio quality measure is below the selected threshold.
		AM and FM All Digital	MP5 MP6 MA3	Not Valid
1	1	All	MP1 MP2 MP3 MP11 MP5 MP6 MA1 MA3	Reserved

5.2.1.3 TX Digital Audio Gain

For audio stream ID 0b00, header bits 39:35 provide the TX Digital Audio Gain parameter. Refer to Table 5-5 for a definition. For MPS audio, this field defines the audio level adjustment to be applied to the digital audio by the receiver in order to equalize the subjective loudness of the digital audio compared to the analog audio. For SPS audio, this field defines the audio level adjustment to be applied to the digital audio by the receiver in order to equalize the subjective loudness of the digital audio of the current program compared to that of the other audio programs.

Table 5-5: TX Digital Audio Gain Control

Value	Indicated RX Digital Audio Level Adjustment
Reserved	...
0b11000	-8 dB
0b11001	-7 dB
0b11010	-6 dB
0b11011	-5 dB
0b11100	-4 dB
0b11101	-3 dB
0b11110	-2 dB
0b11111	-1 dB
0b00000	0 dB
0b00001	+1 dB
0b00010	+2 dB
0b00011	+3 dB
0b00100	+4 dB
0b00101	+5 dB
0b00110	+6 dB
Reserved	...

5.2.1.4 Header Expansion Flag

The Header Expansion Flag (HEF) is used to indicate the presence of additional fields within the PDU header. The HEF is set to 0b1 when there is a Header Expansion field present. The first Expansion field is inserted immediately following the Locator fields. Refer to Subsection 5.2.1.6 for a detailed description of the Header Expansion Fields.

5.2.1.5 Locator Fields

The bit organization of 16-bit and 12-bit locator fields is shown in Figure 5-4 and Figure 5-5 respectively. Each of the NOP locators points to the location of the last byte of the corresponding encoded audio packet for each of the NOP packets (partial or full) in the PDU. The location is relative to the first byte of the PDU (Byte 0). Each 16-bit locator consists of two bytes. The 12-bit locators consist of one byte and a nibble. The next 12-bit locator begins with the next nibble. Bit b_{NOP-1}^0 is sent first and bit b_{NOP-1}^{15} is sent last. The bit length of the locators is defined by the audio codec mode as shown in Table 5-2.

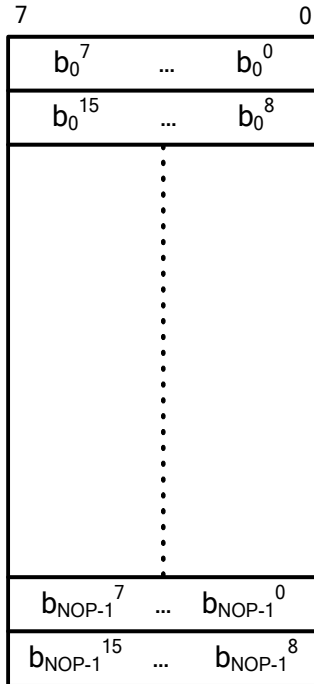
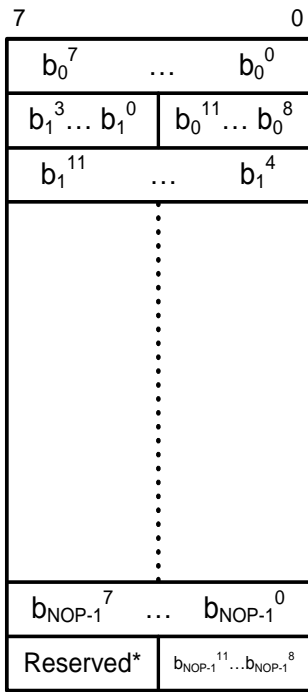

Figure 5-4: Locator Fields – 16-Bit



* is unused when NOP is odd

Figure 5-5: Locator Fields – 12-Bit

5.2.1.6 Header Expansion Fields

The header expansion field bits are defined in Table 5-6.

Table 5-6: Header Expansion Field Bits – Definitions

# of Bits	Description	Comments	
1	HEF Header Expansion Flag	Header Expansion Flag (HEF) is set to 0b1 when optional additional Header Expansion fields are inserted immediately following the HEF	
3	Header Expansion ID	Bits	Header Expansion Field Indications/Formats/Types
		0b000	Class Indication This value for the Header Expansion ID field indicates the Class and is provided according to the description in Subsection 5.2.1.6.1
		0b001	Program Number Indication This value for the Header Expansion ID field indicates that the Program Number is provided according to the description in Subsection 5.2.1.6.2
		0b010	Program Type Indication This value for the Header Expansion ID field indicates that the Program Type is provided according to the description in Subsection 5.2.1.6.3
		0b011	Reserved (Pre-defined) For details see Subsection 5.2.1.6.4
		0b100	PDU Marker Indication This value for the Header Expansion ID field indicates that the PDU Marker is provided according to the description in Subsection 5.2.1.6.5
		0b101	Reserved
		0b110	Reserved
		0b111	Reserved
N/A	Expansion Content	Header Expansion Content – depends on the Header Expansion ID	

As shown in Table 5-6, the Header Expansion Field also contains a one bit HEF. This flag serves the same purpose as the HEF in the main header; that is, to indicate the presence of additional header expansion fields. It is set to 0b1 when an additional Header Expansion Field is present. All additional Expansion fields are inserted consecutively after the first Expansion field. Each Header Expansion field consists of one byte. Each HEF indication is associated with the next header expansion byte immediately following. The HEF bit in the last Header Expansion field is set to 0b0.

The maximum number of Header Expansion field bytes is limited to 16. In streams containing PSD, the expansion bytes will reduce the number of PSD bytes that can be sent for that PDU. If there is no PSD present or if the expansion bytes exceed the allocated PSD capacity, then the system has the option to dynamically scale back the number of bytes allocated for audio to allow for header expansion bytes. The location of the last byte of PSD – La Location – points to the last location of the Expansion Fields when it exceeds the amount of PSD.

Figure 5-6 shows the Header Expansion Flag and the indication of additional Header Expansion Fields.

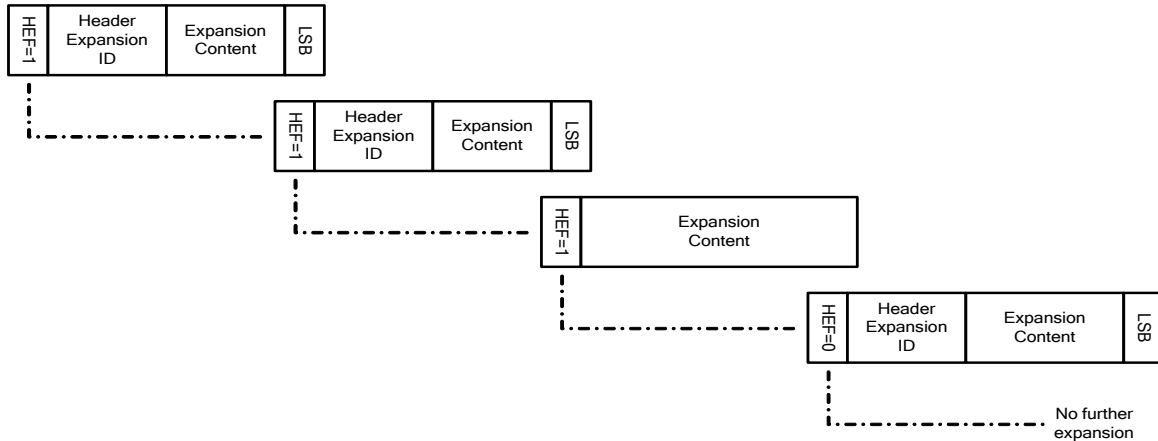

Figure 5-6: Header Expansion Fields – Example

The Header Expansion ID is used to show what type of indication is provided. The Expansion Content field is primarily used to define the type of indication provided. As shown in Table 5-6, the format of the Expansion Content field depends on the Header Expansion ID and may contain any or all of the following indications:

- a) Class Indication – To identify and manage different classes of programs
- b) Program Number – To identify and manage programs
- c) Program Type – To identify the different program types and access type to the program
- d) PDU Marker – A sequential number indicating the PDU placement in a sequence of PDUs

The rules for including a header expansion indication are as follows,

- i. If a single PDU contains more than one Header Expansion Field, then the fields shall be arranged in an ascending order based on the Header Expansion ID.
- ii. Any header expansion values not present in a PDU shall be considered 0 (zero) by the receiver audio transport. The exception to this rule is the class indication. If the class indication is not present in a PDU, then class does not apply.
- iii. MPS does not have to include Program Number, unless PDU displacement (see displacement bit in Figure 5-9) is indicated or additional header expansions are included.
- iv. SPS must include Program Number. Other fields are optional, unless they carry information that is necessary for proper use of the audio program (or audio segment in the program).
- v. When a program has access limitations (Conditional Access), Class Indication (Header Expansion ID 0b000), Program Number Indication (Header Expansion ID 0b001) and Program Type Indication (Header Expansion ID 0b010) must be included.

5.2.1.6.1 Class Indication

If the Header Expansion ID is set to 0b000 (Class Indication), then the Expansion Content indicates the Class of the current program.

The Class Indications are listed and described in Table 5-7.

Table 5-7: Class Indications

Value	Indicated Class	Comments
0b0000	Restricted	0b0000 shall not be used.
0b0001	CA Program	Must be present to indicate a program that is conditionally-accessed (Does not apply to program number 0).
0b0010 to 0b1111	Reserved	---

Class Indication, when present, shall always be the first header expansion in the PDU. Class Indication may be used to provide additional information in association with the Program Number.

Class 0b0000 is restricted and cannot be defined for future applications. Class 0b0001 indicates a conditionally-accessed program. For MPS, Class Indication 0b0001 shall not be used since MPS is defined as a free-access program. For free-access SPS programs, class 0b0001 shall not be sent.

If class 0b0001 is sent, then the Access bit in header expansion 0b010 (Program Type Indication) shall also be sent with the Access bit set to 0b1.

Note that a program may be indicated as being conditionally accessed, but may or may not be scrambled (encrypted). For example, a program may normally be conditionally accessed, but may contain unencrypted material for some period of time that is of interest to all listeners.

5.2.1.6.1.1 Header Expansion for Class Indication

The Header Expansion for the Class Indication is shown in Figure 5-7.

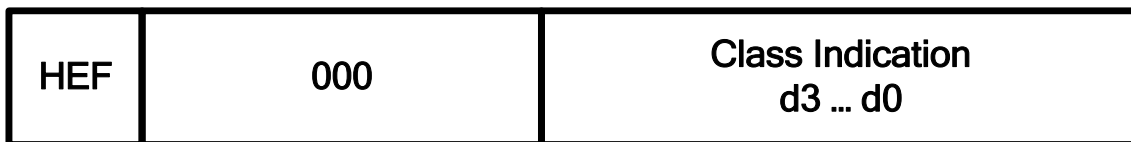

Figure 5-7: Header Expansion – Class Indication

5.2.1.6.2 Program Number Indication

If the Header Expansion ID is set to 0b001 (Program Number indication), then the Expansion Content contains the Program Number for the current PDU. The program number, together with the Class Indication uniquely identifies the PDU content.

The Program Number indication is used by the Audio Transport to identify and manage the MPS or SPS programs that are transmitted. For the Main Program Service, the program number shall be set to 0b000 and the Class Indication shall not be sent. For SPS, where the Class Indication is either set to 0b0001 (conditionally accessed) or is not sent (not conditionally accessed), the program number can be designated by the broadcasting system using any non-zero Program Number (0b001 through 0b111). For SPS, where the Class Indication is sent and is a number other than 0b0001, the Program Number can be designated by the broadcasting system using any number (0b000 through 0b111). SPS programs are not required to be numbered sequentially.

A supplemental program can be added or removed without affecting the enumeration of the main program or existing supplemental programs being transmitted. Unless the Class Indication is used, the Program Number shall always be the Header Expansion that occurs first in the PDU. It must be placed before the Program Type, Program Segment ID, or PDU Marker. For MPS, the Program Number Indication is sent only if additional Header Expansion fields are used to indicate Program Type, Program Segment ID, or PDU Marker. For SPS, the Program Number Indication is always sent.

5.2.1.6.2.1 Header Expansion for Program Number

The Header Expansion for the Program Number indication is shown in Figure 5-8.



Figure 5-8: Header Expansion – Program Number Indication

The Expansion Content contains the Program Number indication (0 to 7). The LSB is indicated as “Reserved”. By default, it has to be set to 0b0. However, setting it to 0b1 indicates that the Program Number indication is followed by two additional bytes of reserved header expansion content, as shown in Figure 5-9.

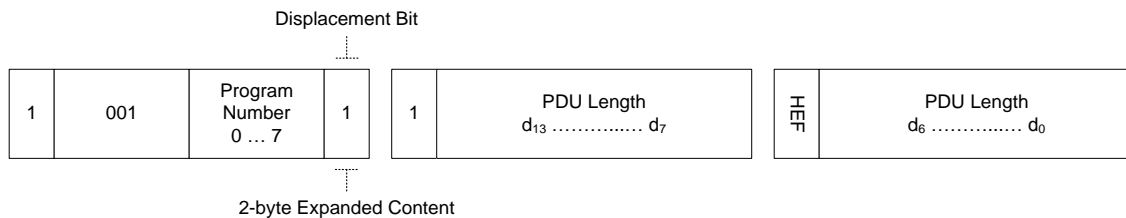

Figure 5-9: Header Expansion – 2-byte Expansion

If the displacement bit is set, two additional expansion bytes are used to indicate the displacement. The displacement points to the last byte of the PDU. Any data placed between the last audio packet locator and the indicated end of the PDU is reserved for future use.

5.2.1.6.3 Program Type Indication

If the Header Expansion ID is set to 0b010 (Program Type Indication), then the Expansion Content contains the Program Type. The Program Type Indication represents the program content by classifying it as one of the pre-defined types that are familiar to the receiver. It enables the receiver to search and sort through the variety of program content being broadcast.

The audio program types numbered zero through 31 are defined for use in the HD Radio system and are in accordance with NRSC-4 (Reference [29]). Additional program types can be included as required, according to: <http://hdradio.com/broadcasters/us-regulatory/nrsc-supplemental-information>.

For a multi-stream configuration, the Program Type is required and indicated only on the core (main) stream.

The Program Type Header Expansion includes a 1-bit flag to indicate the designated accessibility to the program. When this flag is set to 0b0 (zero), it indicates that the program is free of any access limitations. When this flag is set to 0b1 (one), it indicates that the program is delivered with access limitations (Conditional Access). The actual details of the instantaneous access conditions are conveyed separately; i.e. a program may be designated as a CA program but may or may not be encrypted.

When no access limitations are applied, the Program Type need not be transmitted. When access limitations apply, the Program Type shall be transmitted. It is transmitted every PDU while in audio codec modes 0b0000 or 0b1010. It is transmitted at least once every eight PDUs while in audio codec modes 0b0001, 0b0010, 0b0011 or 0b1101.

Concurrently, the same Program Type Indication is optionally included by the broadcast system in the fast-acquired SIS information. This is achieved by adding additional fields to the SIS PDUs passed through the PIDS logical channel. Refer to [6] for details.

The Program Type Expansion Content in the Program Type Header Expansion can be changed without any interruption to the current program.

5.2.1.6.3.1 Header Expansion for Program Type

The Header Expansion for the Program Type indication is shown in Figure 5-10.

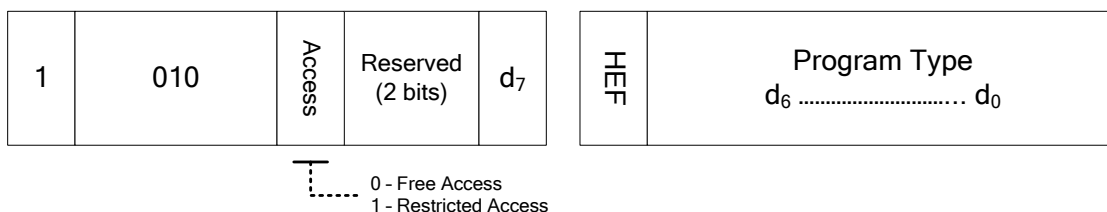

Figure 5-10: Header Expansion – Program Type

The Header Expansion for the Program Type indication consists of two expansion bytes. The first byte contains the Header Expansion ID for the Program Type. It also contains the “Access” flag. The Program Type number is then constructed in the second expansion byte which contains the seven LSBs of this Program Type number. The LSB of the first byte is then used as the MSB of the second byte to construct the actual 8-bit Program Type number. There are two bits of Reserved Expansion Content in the first byte and these two bits may be used to further expand the Program Types.

5.2.1.6.4 Reserved Header Expansion

If the Header Expansion ID is set to 0b011, then the Header Expansion is pre-defined as shown in Figure 5-11.

5.2.1.6.4.1 Header Expansion for Program Segment ID

The Header Expansion for the Program Segment ID is shown in Figure 5-11.

If LEN = 0, expansion is four bytes

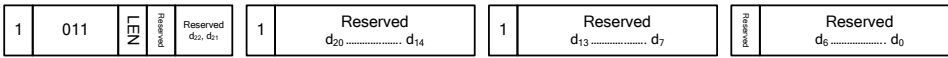

If LEN = 1, expansion is five bytes

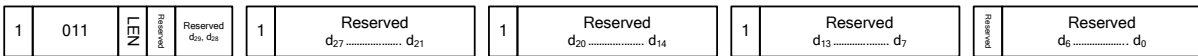

Figure 5-11: Header Expansion – Program Segment ID

5.2.1.6.5 PDU Marker Indication

If the Header Expansion ID is set to 0b100 (PDU Marker indication), then the Expansion Content contains the PDU Marker.

The HD Radio broadcasting system generates and applies the PDU Marker in the Header Expansion fields. It is an optional parameter that is used to uniquely identify the PDU in a program, for a purpose, such as access control management to programs. The default start value is zero.

For a multi-stream configuration, the PDU Marker is indicated only on the core stream.

When no access limitations are applied or no reference is made to specific audio PDUs, the PDU Marker need not be transmitted. When access limitations apply or reference, for any specific purpose, is made to audio PDUs, the PDU Marker shall be transmitted. It is transmitted every PDU, while in audio codec modes 0b0000 or 0b1010. It is transmitted once every eight PDUs, within PDU Sequence Number 0 (bits 32, 46-47 in the PDU header), while in audio codec modes 0b0001, 0b0010, 0b0011 or 0b1101.

The Header Expansion for the PDU Marker indication can be changed without any interruption to the current program. The PDU Marker start number default is zero, but the broadcasting system may assign it as convenient. The number is incremented every long PDU (audio codec modes 0b0000 or 0b1010) and every short PDU coincident with L1 block number 0 (audio codec modes 0b0001, 0b0010, 0b0011 or 0b1101).

5.2.1.6.5.1 Header Expansion for PDU Marker

The Header Expansion for the PDU Marker indication is shown in Figure 5-12.

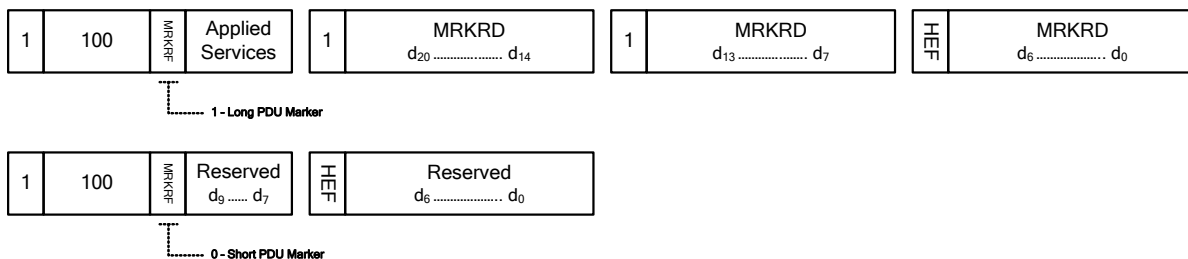

Figure 5-12: Header Expansion – PDU Marker

The first byte of the Header Expansion for PDU Marker contains a 1-bit field (MRKRDF) to indicate the length of the PDU Marker header expansion: 0b1 indicates a 4-byte header expansion for PDU Marker and 0b0 indicates a 2-byte header expansion for PDU Marker. The 2-byte header expansion is reserved for future use as shown in Figure 5-12.

The first byte of a 4-byte Header Expansion for PDU Marker (“Long PDU Marker”) contains a 3-bit field that indicates the “Applied Services” in the PDU payload. This is further explained in Table 5-8. If the value for the “Applied Services” indication is set to 0b001, then this indication signals that the audio is encrypted. When no processing / encryption is applied (conveyed/signaled by a value of 0b000 for the “Applied Services” indication), the header expansion still indicates the PDU Marker. The Applied Services Indication is allowed with every increment to the marker. Thus, content encryption may be dynamic, and may change on any marker boundary.

If the value for the “Applied Services” indication is set to 0b001 and a receiver is not entitled for the encrypted service, the receiver shall inhibit the PSD data and the audio PDU will not be sent to the audio decoder within the receiver.

The PDU Marker consists of 21-bits which span across the remaining three bytes of the Header Expansion. The PDU Marker resolution is a single long PDU (L1 frame equivalent) for all audio codec modes. For audio codec modes 0b0000 or 0b1010, it is also indicated at a long PDU rate. For audio codec modes 0b0001, 0b0010, 0b0011, or 0b1101, which employ short PDU, it can be indicated at a short PDU rate, but the indicated marker value can only change at a long PDU rate. This means that the PDU Marker resolution is equivalent to one L1 frame period, and thus also equivalent to an ALFN unit.

The PDU Marker is continuous; which means that its same-number representation repeats every 2^{21} L1 frames. Thus, the PDU Marker spans approximately 36 days.

Table 5-8: Applied Services Indication

Applied Services Indication	Applied Services Meaning
0b000	None – Content is not altered
0b001	Encoded audio packets are encrypted. This Indication shall only be used if: Class Indication (Expansion byte 0b000) = 0b0001 and Access bit of Expansion Byte 0b010 = 0b1 to indicate a CA service
0b010 to 0b111	Reserved

5.2.2 Program Service Data (PSD) Processing

PSD is available within the Audio Transport layer. The Audio Transport interface accepts PSD PDUs from the PSD Transport [10]. A PSD byte-stream is supported by each active encoder stream but utilized for the core stream only. Refer to Table 5-9 for the typical/average number of data bytes per PDU per stream for each of the various audio codec modes. Rates are not guaranteed, as they may be instantaneously reduced by Header Expansion. The rates may also be instantaneously increased, as a result of the audio format. They may also be affected by different configurations, especially at low audio bit rates.

Table 5-9: Program Service Data per Audio Codec Mode

Audio Codec Mode	Typical Use	Stream ID (bits)	Stream Type	Nominal Program Service Data Rate (Bytes/PDU)
0b0000	FM Hybrid	00	Core	128
0b0001	FM All Digital	00	Core	16 §
		01	Enhanced	0
0b0010	AM Hybrid / All Digital	00	Core	16 §
		10	Enhanced	0
0b0011	FM All Digital	00	Core	16 §
		01	Enhanced	0
0b0100 to 0b1001	Reserved	-	-	-
0b1010	FM Hybrid / All Digital	00	Core	128
		10	Enhanced	0
0b1011 to 0b1100	Reserved	-	-	-
0b1101	FM Hybrid / All Digital	00	Core	16 §
0b1110 to 0b1111	Reserved	-	-	-

§ Nominally, 16 bytes are allocated for PSD. The actual number of bytes for PSD must be decreased by the number of header expansion bytes utilized within a given PDU. In addition, the actual number of available bytes for PSD may be increased to up to 21 in a specific PDU, when not all of the bytes in that PDU are consumed by encoded audio packets.

5.2.3 Error Control Codes

Error control codes are utilized in various portions of the PDU in order to provide for error detection and/or correction in the receiver. The codes included are: Reed Solomon (RS) and cyclic redundancy check (CRC).

5.2.3.1 Packet Header Protection

In all streams within all audio codec modes, the header payload is protected by an error correction (and detection) code. The code in use is RS of GF (2⁸). The actual code word is shortened to a length of 96 bytes - (96, 88, 2⁸). Each codeword consists of the header payload bytes along with eight redundancy (parity) bytes. The header payload is described in Figure 5-1.

- Primitive polynomial is $x^8+x^4+x^3+x^2+1$
(100011101 in binary notation, where the LSB is on the right)

- Generator polynomial is

$$g(x) = a^{36} + a^{203}x + a^3x^2 + a^{220}x^3 + a^{253}x^4 + a^{211}x^5 + a^{240}x^6 + a^{176}x^7 + x^8$$

where “a” is a root of the primitive polynomial.

- To compute the parity bytes, it is assumed that bytes 0 through 158 of the un-shortened input codeword are zero. Byte 160 is the rightmost byte shown in Figure 5-1. Byte 247 of the RS codeword is the first byte (leftmost) of the MPS PDU Control Word shown in Figure 5-1. The parity bytes are then computed, where the last parity byte of the RS codeword is the first byte (leftmost in Figure 5-1) in the audio PDU.

5.2.3.2 Packet Integrity Control

Each encoded audio packet is accompanied by a CRC-8 code for the purpose of receiver integrity check. Note that if a packet is split into two partial packets in a PDU, both partial packets will have their own individual CRC applied.

The generator polynomial used is:

$$g_8(x) = x^8 + x^5 + x^4 + 1$$

This polynomial can be represented in binary form as 100110001 where the LSB is on the right. The CRC value is computed as follows:

Perform modulo-two division of the encoded audio packet by the generator polynomial $g_8(x)$. The 8-bit remainder inserted into the PDU will have the least significant bit directly following the last bit of the encoded audio packet.

5.2.4 Audio Encryption

When audio encryption is applied, encoded audio packets are encrypted. Each packet is encrypted separately and no byte aggregation or buffering across packets is allowed. For each packet, the first 64 bytes of the packet are encrypted. If the packet is shorter than 64 bytes, then the entire packet is encrypted. The packet encryption is not applied to the CRC-8 byte that is appended to each packet.

5.2.4.1 Marker Timing

For the purpose of synchronization between the audio PDU and the encryption data (codeword), the indicated PDU Marker applies at very specific times.

For Long PDUs, the marker is conveyed within every PDU and applies to that PDU.

For Short PDUs, the marker is conveyed within PDU number 0, and may also be conveyed within PDU number 3, but it applies from PDU number 0 to PDU number 7.

Since the PDU Marker resolution is one long PDU (one L1 frame), the encryption codeword may only change from one long audio PDU to another, but not faster.

5.2.4.2 Encoded Audio Packet Encryption

Encoded Audio Packet encryption is based on packet boundaries, rather than precise PDU boundaries. The encryption data (codeword) is applied to the first complete packet in the indicated PDU to the end of the last partial packet of the indicated PDU, even if it is partial and spills over to a newly indicated PDU.

Specifically, in long PDUs (core audio in audio codec modes 0b0000 or 0b1010), the same encryption data must be used from the first complete encoded audio packet of a PDU to the end of first partial packet in the next PDU.

In short PDUs (core audio in audio codec modes 0b0001, 0b0010, 0b0011 or 0b1101), the same encryption data must be used from the first complete encoded audio packet of a PDU number 0 through PDU number 0 to 7 and to the end of first partial packet in the next PDU number 0. This approach guarantees that the encryption time used by specific encryption data is the same, regardless of the specific audio transport (audio codec mode) used for the specific program.

GLOSSARY

Audio Frame	<p>The unit of information payload exchanged from the Audio Interface and the Audio Transport Layer.</p> <p>Audio frames are comprised of 2048 audio samples at a sampling rate of 44.1 kHz.</p>
Audio Quality	<p>High audio quality is required by the system specification for each of the primary L1 service modes while maintaining the necessary compression rate.</p>
Audio Encoder	<p>Audio Encoder refers to the audio processing at the transmission side only.</p> <p>On the other hand, audio codec refers to the combined transmit and receive audio processing functions in the system.</p>
MPS/SPS PDU	<p>Refers to the output of the Audio Transport process in the broadcasting system.</p> <p>An MPS/SPS PDU consists of protocol information followed by a sequence of encoded audio packets.</p> <p>MPS/SPS PDUs may be output from one to two streams depending on the audio codec mode.</p>
Encoded Audio Packet	<p>Compressed audio frames output from the Audio Encoder.</p> <p>These may be divided into one to two output streams depending on the audio codec mode.</p>
Layer 1 (L1)	<p>The lowest protocol layer in the HD Radio Protocol Stack</p> <p>Also known as the waveform/transmission layer</p> <p>Primarily concerned with the transmission of data over a communication channel.</p> <p>Includes framing, channel coding, interleaving, modulation, etc. over the AM radio link at the specified service mode.</p>
Layer 2 (L2)	<p>The Channel Multiplex layer in the HD Radio Protocol Stack.</p> <p>Multiplexes data from the higher layer services into logical channels (partitioned into L1 frames, block pairs, and blocks) for processing in Layer 1.</p>
Main Program Service (MPS)	<p>The Main Program Service preserves the existing analog radio-programming formats in both the analog and digital transmissions.</p> <p>In addition, Main Program Service includes digital data, which directly correlates with the audio programming.</p>
Supplemental Program Service (SPS)	<p>Supplemental Program Service is a secondary program broadcast simultaneously with the main program using any logical channel.</p>
Multi-stream	<p>Audio information, split into two individual streams of encoded audio packets.</p> <p>This capability is necessary to support both fast tuning and graceful degradation requirements.</p>

Protocol Control Information (PCI)

Protocol Control Information (PCI)

- Stream ID for the associated payload (that is, MPS PDU)
- Length(s) of associated payload
- Cyclic Redundancy Check (CRC) for the PCI

Protocol Data Unit (PDU)

A Protocol Data Unit (PDU) is the structured data block in the HD Radio system that is produced by a specific layer (or process within a layer) of the transmitter protocol stack.

The PDUs of a given layer may encapsulate PDUs from the next higher layer of the stack and/or include content data and protocol-control information originating in the layer (or process) itself.

The PDUs generated by each layer (or process) in the transmitter protocol stack are inputs to a corresponding layer (or process) in the receiver protocol stack.